



***VÁLVULAS WORCESTER
DE MÉXICO, S.A. DE C.V.
RHINO VALVES WORLDWIDE®***



CATÁLOGO DE PRODUCTOS
PRODUCT CATALOG

www.worcester.com.mx



Certificaciones Certifications



COMISIÓN FEDERAL DE ELECTRICIDAD



LAPEM.

LABORATORIO DE PRUEBAS DE EQUIPOS Y MATERIALES
CONSTANCIA DE CALIFICACIÓN DE PROVEEDOR

NÚMERO
413/14

SE HACE CONSTAR QUE LA EMPRESA CUYOS DATOS SE DESCRIBEN A CONTINUACIÓN:

RAZÓN SOCIAL:	VALVULAS WORCESTER DE MEXICO S.A. DE C.V.		
PLANTA O DIVISIÓN:	N/A		
DOMICILIO:	Calle Maíz No. 203 Valle del Sur CP: 09819	IZTAPALAPA	DISTRITO FEDERAL MEXICO

HA SIDO EVALUADA CONFORME A LOS PROCEDIMIENTOS ESTABLECIDOS EN ESTA GERENCIA, HABIENDO SIDO CALIFICADA COMO PROVEEDOR APROBADO PARA EL SUMINISTRO DE LOS BIENES O SERVICIOS INDICADOS AL REVERSO.

LOS RESULTADOS, CONDICIONES, COMPARISOS Y DETALLES DE LA ACTIVIDAD ESTÁN EXPRESADOS EN EL REPORTE DE REFERENCIA TENIENDO ESTA CONSTANCIA LA VISIBILIDAD ESPECIFICADA, RESERVIÁNDOS EL DERECHO DE MODIFICARLA EN CUALQUIER MOMENTO, SI LAS CONDICIONES QUE LE DIERON ORIGEN SON ALTERADAS.

ESTA CONSTANCIA DE CALIFICACIÓN CANCELARÁ CUALQUIER OTRA CONSTANCIA O DOCUMENTO DE CALIFICACIÓN EMITIDO CON ANTERIORIDAD PARA LA EMPRESA ATRIBUYA SEÑALADA.

FECHA DE EMISIÓN	14/06/2014	VALIDEZ	24 Meses a partir de su emisión
------------------	------------	---------	---------------------------------

REPORTE DE REFERENCIA: R-0604754



César Jesús Pinto Aguilar
Encargado del Depto. de Evaluación y Desarrollo de Proveedores



Alberto Alejandro Montoya Vargas
Subgerente de Gestión de la Calidad

Valvulas Worcester de México,® S.A. de C.V. /Rhino Valves Worldwide® /Valtaco consiente de la calidad de las válvulas para la seguridad, la salud del personal y la protección de la propiedad del cliente, diseña, fabrica, inspecciona y prueba sus productos conforme a estándares internacionales y requisitos del cliente.

Es nuestro compromiso de calidad proveer a nuestros clientes productos de primera clase, precio competitivo y tiempo de entrega inmejorable.

El Sistema de Aseguramiento de Calidad de Worcester/Rhino se sustenta en la fabricación de válvulas con cero defectos, para ello la empresa cuenta con certificación de calidad ISO 9001 (Certificado por DNV-GL), API 6D. Nuestras válvulas están certificadas a prueba de fuego por Lloyd's Register además de tener constancia de proveedor confiable emitido por LAPEM.

Valvulas Worcester de México,® S.A. de C.V. / Rhino Valves Worldwide® Valtaco is aware about the importance of the quality in our valves in terms of personnel safety and customer's property care. Our products are designed, manufactured, inspected and tested according to international standards and special customer requirements.

It is our quality compromise to supply to our customers first class products with competitive price and excellent delivery time.

Worcester/Rhino's quality system is based on the "zero defects" manufacturing, so in order to achieve this goal our company have an ISO 9001 certification (certified by DNV-GL), API 6D, Fire Safe (certified by Lloyd's Register) as well as a LAPEM trustable supplier.



Lloyd's Register Type Approval Certificate

This is to certify that the undernoted products have been tested with satisfactory results in accordance with the relevant requirements of the Lloyd's Register Type Approval System, 2002.

This certificate is issued to:

PRODUCER	Valvulas Worcester de México, S.A. de C.V. /Rhino Valves Worldwide / Valtaco
PLACE OF PRODUCTION	Maíz 203 Colonia Valle del Sur, México D9819, D.F.
DESCRIPTION	Quarter turn Fire tested Ball Valves
TYPE	Series 44 and 151 Series 152 Series 154 Series 15 Series 45 and 26
SIZE & RATINGS	Class 900 Size 1/2" to 2" Carbon Steel and Stainless Steel
APPLICATION	Fire tested ball valves for Marine, Offshore and Industrial applications

Certificate No.	13160001
Issue Date	22 Jun 2013
Expiry Date	22 Jun 2018
Sheet	1 of 2



Claudio Hail
Lloyd's Register North America Inc.

Lloyd's Register North America Inc.
1550 Executive Parkway, Dallas, TX 75207

Lloyd's Register Group Limited, its affiliates and subsidiaries and their respective officers, employees or agents, individually and collectively, shall not be liable in any capacity for any loss, damage or expense caused by reliance on the information or advice provided in this document or for any other matter, unless the person has signed a contract with the relevant Lloyd's Register Group entity for the provision of this information or advice, and in that case any responsibility or liability is excluded on the terms and conditions set out in that contract.



Certificate of Authority to use the Official API Monogram
License Number: 6D-1624 ORIGINAL

The American Petroleum Institute hereby grants to
VALVULAS WORCESTER DE MEXICO, S.A. DE C.V.
Rhino Valves Worldwide China Facility
North Weiqi Road
West Yanlu District
Yancheng, Jiangsu
People's Republic Of China

the right to use the Official API Monogram on manufacturing products under the conditions in the official publications of the American Petroleum Institute entitled API Spec Q1¹ and API 6D and in accordance with the provisions of the License Agreement.

In all cases where the Official API Monogram is applied, the API Monogram shall be used in conjunction with this certificate number: **6D-1624**

The American Petroleum Institute reserves the right to revoke this authorization to use the Official API Monogram for any reason satisfactory to the Board of Directors of the American Petroleum Institute.

The scope of this license includes the following: Ball Valves

AMS Exclusions: No Exclusions Identified as Applicable

Effective Date: MARCH 7, 2016
Expiration Date: MARCH 7, 2019

To verify the authority of this license, go to www.api.org/compliance.



The President, API Global Industry Services



DNV BUSINESS ASSURANCE

MANAGEMENT SYSTEM CERTIFICATE

Certificate No. 133848-2013-AQ-MCI-RvA

This is to certify that

Valvulas Worcester de México, S.A. de C.V. / Rhino Valves Worldwide / Valtaco

Calle Maíz No. 203, Colonia Valle del Sur, Delegación Iztapalapa, C.P. 09819, México D.F.

has been found to conform to the Management System Standard:

ISO 9001:2008

This Certificate is valid for the following product or service ranges:

Design and Manufacture of Ball Valves and Commercialization of Related Accessories and Equipment

Initial Certification date: March 22, 2013	Place and date: México D.F., March 22, 2013
This Certificate is valid until: March 22, 2016	For the Accredited Unit: DNV NORGE VERITAS CERTIFICATION B.V. THE NETHERLANDS



Mario Antonio Hernández
Lead Auditor



MGMT.SYS.
RVA 6024



Gustavo Guadalupe
Country Manager

Lack of fulfillment of conditions as set out in the Certification Agreement may render this Certificate invalid.
Accreditation and the National Board of Certification (NBO) is a Division of DNV GL, The Netherlands - +31 20 238 8000 - www.dnvgl.com



Lloyd's Register Type Approval Certificate

This is to certify that the undernoted products have been tested with satisfactory results in accordance with the relevant requirements of the Lloyd's Register Type Approval System, 2002.

This certificate is issued to:

PRODUCER	Valvulas Worcester de México, S.A. de C.V. /Rhino Valves Worldwide/Valtaco
PLACE OF PRODUCTION	Maíz 203 Colonia Valle del Sur, México 09819, D.F.
DESCRIPTION	Quarter turn Fire tested Ball Valves
TYPE	Series 44 and 151 Series 152 Series 154 Series 15 Series 45 and 26
SIZE & RATINGS	Series 44 and 151 Size 1/2" to 2" Class 400 & 600 Carbon Steel and stainless Steel PS-44-446 and PS-44-466 Series 152 Size 1/2" to 8" Class 150# & 300# Carbon Steel and stainless Steel Code PS-152-446 and PS-152-466 Series 154 Size 1/2" to 2" Class 400 & 600 Carbon Steel and stainless Steel PS-N44-446 & PS-N44-466 Series 15 Size 1/2" to 6" Class 150 Carbon Steel and stainless Steel PS-15-446 and PS-15-466 Series 45 and 26 Size 2 1/2" to 8" Class 300 Carbon Steel and stainless Steel Code PS-45-446 and PS-45-466

Certificate No.	11/60012
Issue Date	27 July 2011
Expiry Date	26 July 2016
Sheet	1 of 2



Claudio Hail
Lloyd's Register North America Inc.

Lloyd's Register North America Inc.
1550 Executive Parkway, Texas, 77077

Lloyd's Register, its affiliates and subsidiaries and their respective officers, employees, or agents, individually and collectively, are referred to in this clause as the "Lloyd's Register Group." The Lloyd's Register Group assumes no responsibility and will not be liable to any person for any loss, damage, or expense caused by reliance on the information or advice provided in this document or for any other matter, unless the person has signed a contract with the relevant Lloyd's Register Group entity for the provision of this information or advice, and in that case any responsibility or liability is excluded on the terms and conditions set out in that contract.

Acerca de
ABOUT



Válvulas Worcester de México®

Siendo una empresa 100 % mexicana, Válvulas Worcester de México® S.A. de C.V. fue fundada en 1963 bajo licencia de Worcester Controls.

Con más de 50 años de experiencia en la fabricación de válvulas de bola, ofrecemos variedad de diseños cuya operación puede ser manual o automatizada para aplicaciones en la industria, además de los diversos accesorios que el mercado demanda.

La calidad que precede a las válvulas de bola, la infraestructura de nuestra planta, el alto volumen de producción que mantenemos y nuestra calidad de servicio nos permiten ofrecerle la atención inmediata y confiable para satisfacer sus necesidades.

El éxito de Válvulas Worcester está definitivamente ligado con nuestro personal, quienes siempre están un paso adelante, mejorando nuestros diseños, buscando siempre el mejor rendimiento de nuestros productos, buscando nuevos mercados, logrando excelentes contratos comerciales, pensando en la mejora continua de nuestro sistema.

Válvulas Worcester de México® S.A. de C.V. is a Mexican owned company founded in 1963 under Worcester Controls' license.

With more than 50 years of experience manufacturing ball valves, we are in the position to offer a wide range of products, for manual or automated service, special industrial applications as well as different demanded valve accessories.

Our quality, physical infrastructure, high production volume and after sales service, allows us to provide immediate response to your inquiries in order to satisfy your needs.

Válvulas Worcester's success is definitively linked with our staff whose are always ahead, improving our designs, looking for better performance on our products, entering new markets, achieving excellent commercial contracts and always thinking in continuous improvement of our system.

La confiabilidad y garantía de nuestros productos están avalados por la certificación ISO 9001, API 6D, Lloyds Register y Lapem.

Con más de 50 años de experiencia en el mercado así como el respaldo de las certificaciones antes mencionadas, Válvulas Worcester de México® S.A. de C.V. se mantiene como líder en el mercado en la fabricación de válvulas de bola.

Hemos ampliado nuestra participación en el ámbito internacional y seguimos comercializando nuestros productos bajo el nombre de Rhino Valves Worldwide® exportando válvulas y accesorios a Centro América, Sudamérica, Norteamérica, Medio Oriente, Australia y la Comunidad Europea.

Válvulas Worcester de México® S.A. de C.V. ha mantenido una visión de constante innovación y de vanguardia de acuerdo a los nuevos requerimientos que se presentan para atender las aplicaciones más exigentes de diseño, fabricación, inspección, prueba, automatización, seguridad y servicio post-venta ofreciendo siempre una solución integral a nuestros clientes.



Our quality and high performance is backed by the following certifications: ISO 9001, API 6D, Lloyds Register, Lapem

Based on more than 50 years of experience as well as certifications mentioned above, Válvulas Worcester de México® S.A. de C.V. remains as The ball valve manufacturer leader in México.

Going ahead on the international market, we are currently exporting our valves under our exclusive "Rhino Valves Worldwide®" brand, covering markets in Central, South and North America, Middle East, Australia and The European Community.

Válvulas Worcester de México® S.A. de C.V. has kept constant innovation and is always at the Forefront, in order to achieve the most demanding design applications, manufacturing, inspection, test, automation and after sales service, to provide a comprehensive service to our customers.



Para Servicios Generales • For General Service	
Serie 42 (Economite) • Series 42 (Economite)	p 4
Serie 1000 • Series 1000	p 5
Para Uso Industrial • For Industrial Use	
Serie 400 • Series 400	p 6
Serie 600 • Series 600	p 9
Serie 45 • Series 45	p 11
Bridadas para Uso Industrial • Flanged for Industrial Use	
Serie 15 • Series 15	p 13
Serie 150/300 (Paso Reducido) • Series 150/300 (Reduced Bore)	p 15
Serie 152/302 (Paso Completo) • Series 152/302 (Full Bore)	p 19
Serie 600 Bridada (Paso Completo) • Series 600 Flanged (Full Bore)	p 21
Válvulas Especiales • Special Valves	
Serie 151 (Diseño Corto) • Series 151 (Short Pattern)	p 22
Serie H600 (Alta Presión) • Series H600 (High Pressure)	p 23
Serie 6000 (Alta Presión 2500#) • Series 6000 (High Pressure 2500#)	p 24
Serie 6000 (Alta Presión 900#) • Series 6000 (High Pressure 900#)	p 26
A Prueba de Fuego F-400/F-600 • Series F-400/F-600 Fire Safe	p 27
A Prueba de Fuego F-152/F-302 • Series F-152/F-302 Fire Safe	p 28
3-Vías Serie 400/600 • 3Way Series 400/600	p 30
3-Vías Serie 15 • 3Way Series 15	p 32
Serie 18 Multipuerto • Series 18 Multiport	p 33
Criogénica Serie 400 • Series 400 Cryogenic	p 38
Criogénica Serie 15 • Series 15 Cryogenic	p 40
Sanitaria Serie 400 • Series 400 Sanitary	p 42
Sanitaria Serie 45 • Series 45 Sanitary	p 43
Válvula de Bola Guiada (Tipo Trunnion) • Trunnion Ball Valves	
Forjadas (Serie 82, 83, 84, 85 y 86) • Forged (Series 82, 83, 84, 85 & 86)	p 44
Fundidas (Serie 82, 83, 84, 85, y 86) • Cast (Series 82, 83, 84, 85 & 86)	
Otros Productos • Other Products	
Trampa de Vapor • Steam trap	p 59
Conexión 3000 lb • 3000 lb Connection	p 60
Anexos • Annexes	
Datos Técnicos (Flotante/Esfera guiada) • Technical Data (Floating/Trunnion)	p 62
Como Ordenar • How To Order	p 79



ECONOMITE SERIES 42



Válvula de bola para usos generales WOG (agua, aceite, aire), paso reducido, cuerpo de 2 piezas en medidas de 1/4" a 2" .

Conexiones NPT, BSPP, BSPT.
Opción: libre de grasa

Valve for general use WOG (Water, Oil, Gas) reduce bore, 2 pieces design, in sizes from 1/4" to 2"

Connections NPT, BSPP, BSPT.
Options: Oil free

Serie 42 Materiales de sellos y asientos
Series 42 Seal and seat materials

Asiento <i>Seat</i>	Sello del cuerpo <i>Body seal</i>	Sello del vástago <i>Stem seal</i>
T PTFE	T PTFE	R R-PTFE

Latón • Brass	
B283-C37700	
Válvula <i>Valve</i>	Presión de Trabajo <i>Working Pressure</i>
Serie 42 • <i>Series 42</i>	600 PSI WOG

Dimensiones • *Dimensions*

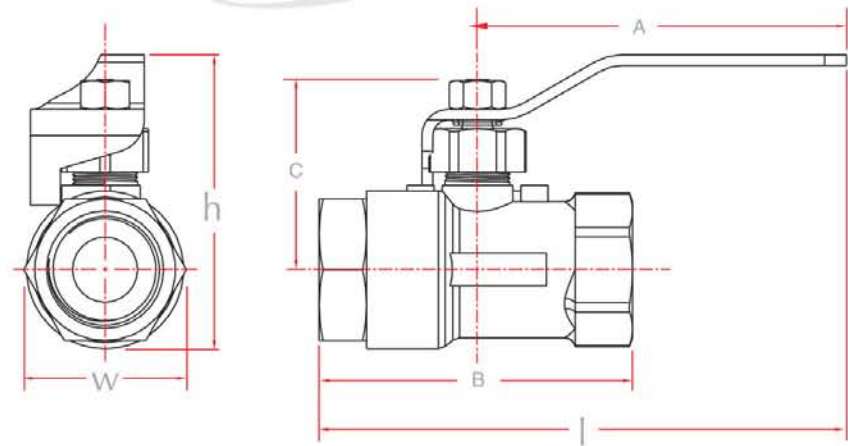

Serie 42 Paso Reducido
Series 42 Reduced Bore

Medida / Size	A	B	C	Paso Bore	Peso / Weight		l	h	W
					kg	lb	Largo /Length	Altura /Height	Ancho /Width
1/4	4.25	2.50	1.94	.410	0.350	.800	5.56	2.96	1.25
3/8	4.25	2.50	1.94	.410	0.350	.800	5.56	2.96	1.25
1/2	4.25	2.50	1.94	.410	0.350	.800	5.56	2.96	1.25
3/4	4.25	2.72	2.06	.540	0.430	.9400	5.66	3.11	1.45
1	4.25	3.62	2.25	.750	0.760	1.700	6.09	3.49	1.90
1 1/2	5.75	4.39	2.94	1.260	2.030	4.500	8.05	4.59	2.80
2	5.75	4.91	3.12	1.500	2.700	5.900	8.20	5.02	3.40

Nota: Dimensiones en pulgadas • *Note: All dimensions in inch*

SERIES 1000



Serie 1000 • Series 1000
Materiales de sellos y asientos • Seal and seat materials

Asiento Seat	Sello del cuerpo Body seal	Sello del vástago Stem seal
T PTFE	T PTFE	R R-PTFE

Válvula Valve	Acero al Carbón • Carbon Steel	Acero Inoxidable • Stainless Steel
	ASTM A216 WCB	ASTM A351 CF8M
Presión de Trabajo • Working Pressure		
Serie 1000 • Series 1000	1000 PSI WOG	

Válvula para usos generales WOG (Agua, Aceite, Gas) de paso completo. Construcción en acero al carbón y acero inoxidable, con vástago antiestático, maneral con seguro de posición.

Nota: ésta serie se fabrica con interiores (esfera y vástago) de acero inoxidable.

Opción: libre de grasa

Valve for general use WOG (Water, Oil, Gas), full bore, strong construction in carbon and stainless steel, provided with antistatic stem, handle with safety device.

Note: This valve is manufactured with stainless steel in ball and stem.

Options: Oil free

Dimensiones • Dimensions

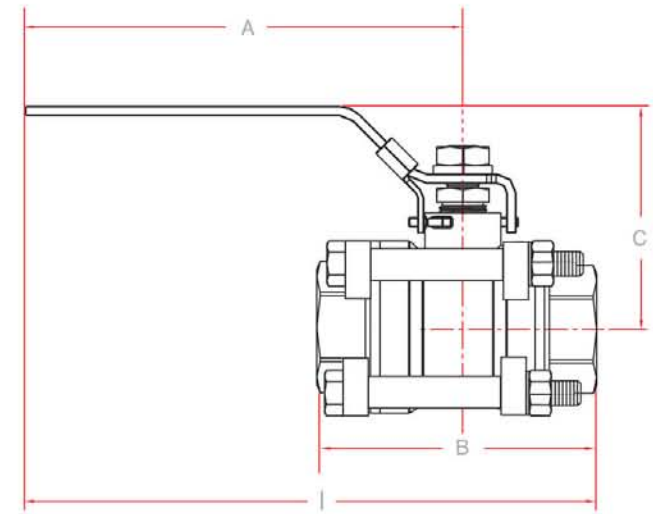
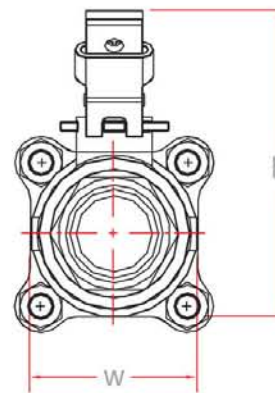

Serie 1000
Series 1000

Medida / Size	A	B	C	Paso Bore	Peso / Weight		l	h	W
					kg	lb	Largo /Length	Altura /Height	Ancho /Width
1/2	4.50	2.76	1.66	.500	.460	1.000	5.93	3.01	1.68
3/4	4.50	2.85	2.44	.750	.590	1.300	5.79	3.41	1.93
1	5.35	3.58	2.83	1.000	1.000	2.200	7.63	4.00	2.34
1 1/2	5.35	4.48	3.39	1.500	2.200	4.800	7.61	4.97	2.18
2	5.35	5.28	3.70	2.000	3.200	7.000	7.97	5.56	3.73

Nota: Dimensiones en pulgadas • Note: All dimensions in inch

SERIES 400 REDUCE and FULL BORE



Ball valve three-piece design, available in sizes from 1/4" to 2", strong construction in brass, carbon and stainless steel. Stem seals for frequent cycles. Connections: NPT, BSPP, BSPT, SW, BW.

Válvula de bola, diseño de 3 piezas, en medida de 1/4" a 2". Construcción robusta en materiales de latón, acero al carbón y/o acero inoxidable. Sellos del Vástago para ciclos frecuentes. Conexiones: NPT, BSPP, BSPT, SW, BW.

Latón • Brass	
B283-C37700	
Válvula Valve	Presión de Trabajo Working Pressure
Serie 400 Latón • Series 400 Brass	600 PSI

OPCIONES:

Diversos materiales para sellos y asientos. Paso Completo, dispositivo para candado, Cuerpo conforme a la norma ISO 5211, (excepto 2" Paso completo, en donde se tiene diseño del cuerpo para adaptación de soporte en trabajo de Automatización). Enchaquetado para control térmico (Solo acero al carbon e inoxidable), maneral oval, libre de grasa, vástago extendido, vástago antiestático, Automa-tización con actuador eléctrico ó neumático. A prueba de Fuego cumple con normativa API 607 Acero al carbon e inoxidable API 6D.

OPTIONS:

Diversity in materials for seals and seats, locking device, Body design according to ISO 5211 (except on 2" where special body design for coupling bracket on automation job). Fire-Safe design, oval handle oil free, 3 ways diverter, cryogenic, antistatic stem, extended stem. The valve can be automated with an electric or pneumatic actuator. In Accordance with API 6D.

Válvula Valve	ANSI B16.34 Clase • Class	Acero al Carbón • Carbon Steel		Acero Inoxidable • Stainless Steel	
		Presión de Trabajo Working Pressure	Presión Max.de Prueba Max. Test Pressure	Presión de Trabajo Working Pressure	Presión Max.de Prueba Max. Test Pressure
Serie 400 • Series 400	400	990 psi	1500 psi	960 psi	1450 psi

Lista de partes
List of components

- 1 Tornillo del cuerpo • Body bolt
- 2 Tapa • Pipe end
- 3 Sello de cuerpo • Body seal
- 4 Asiento • Seat
- 5 Bola • Ball
- 6 Cuerpo • Body
- 7 Tuerca del cuerpo • Body nut
- 8 Vástago • Stem
- 9 Roldana inferior de vástago • Thrust bearing
- 10 Sello de vástago • Stem seal
- 11 Separador • Stem follower
- 12 Roldana cóncava • Belleville washer
- 13 Tuerca de vástago • Retaining nut
- 14 Seguro para tuerca • Lock nut
- 15 Maneral • Handle
- 16 Dispositivo para candado • Locking device

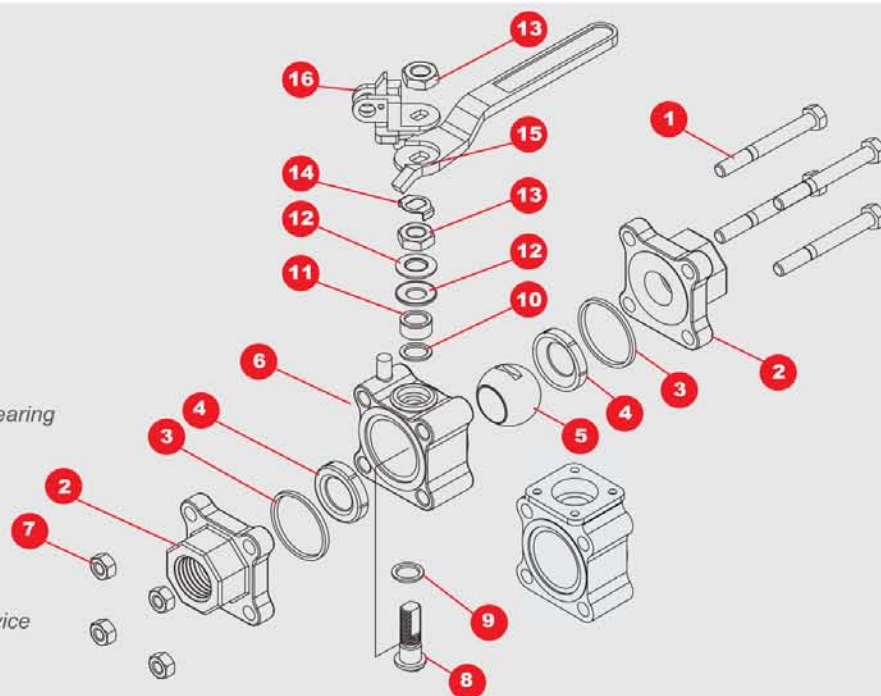

Materiales de Sellos y Asientos • Seal and seat materials

Asiento Seat	Sello del cuerpo Body seal	Sello del vástago Stem seal
B BUNA	B - BUNA	
* T PTFE	* T - PTFE	* R R-PTFE
R R-PTFE	M - MULTIFIL	
M MULTIFIL	V - VITON	
I PTFE + INOX.	G - GRAFOIL	
Y DELRIN		M MULTIFIL
U UHMWPE		
P PEEK		

* Materiales estandar / Standard materials

SERIES 400 REDUCE and FULL BORE



Dimensiones • Dimensions

Serie 400 Paso reducido (Carbón e Inoxidable)

Series 400 (Carbon and Stainless Steel) Reduced bore

Medida / Size	A	B	C	D	Paso Bore	Peso / Weight		Largo / Length	h	w
						kg	lb			
1/4	4.30	1.75	2.61	1.47	.440	0.660	1.400	5.63	2.64	1.77
3/8	4.30	1.71	2.61	1.49	.440	0.620	1.300	5.63	2.58	1.75
1/2	4.30	1.65	2.61	1.51	.440	0.590	1.300	5.63	2.58	1.75
3/4	4.30	1.73	2.83	1.55	.560	0.800	1.800	5.74	2.74	2.00
1	5.75	2.40	3.75	2.17	.810	1.490	3.300	7.57	3.59	2.38
1 1/4	5.86	2.49	4.22	2.35	1.000	2.010	4.400	7.98	3.82	2.63
1 1/2	7.13	3.02	4.62	2.89	1.250	3.330	7.300	9.45	4.62	3.19
2	7.14	3.15	5.01	3.07	1.500	4.400	9.700	9.65	5.00	3.57

Serie 400 Paso completo (Carbón e Inoxidable)

Series 400 (Carbon and Stainless Steel) Full bore

Medida / Size	A	B	C	D	Paso Bore	Peso / Weight		Largo / Length	h	w
						Kg	lb			
1/4	4.30	1.71	2.61	1.49	.440	0.620	1.400	5.63	2.58	1.75
3/8	4.30	1.65	2.61	1.51	.440	0.590	1.300	5.63	2.58	1.75
1/2	4.30	1.73	2.83	1.55	.560	0.80	1.800	5.74	2.74	2.00
3/4	5.75	2.40	3.75	2.17	.810	1.490	3.300	7.57	3.59	2.38
1	5.86	2.49	4.22	2.35	1.000	2.010	4.400	7.98	3.82	2.63
1 1/4	7.13	3.02	4.62	2.89	1.250	3.330	7.300	9.45	4.62	3.19
1 1/2	7.14	3.15	5.01	3.07	1.500	4.400	9.700	9.65	5.00	3.57
2	7.42	4.84	5.87	4.68	2.000	9.910	21.900	10.36	7.12	4.55

Nota: Dimensiones en pulgadas • Note: All dimensions in inch

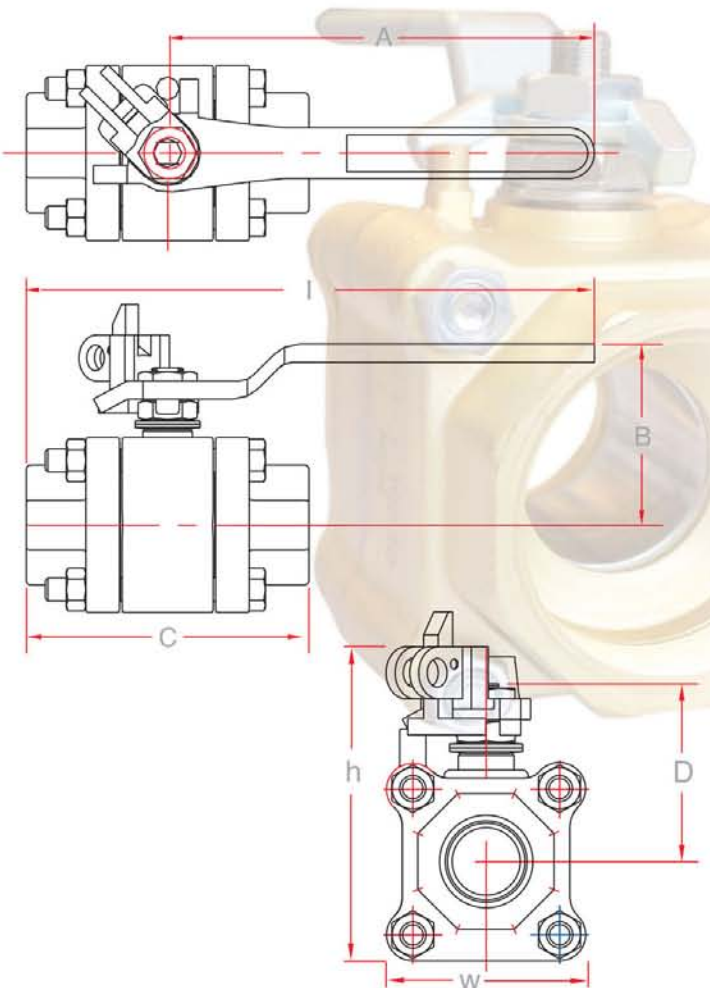

SERIES 400 REDUCE and FULL BORE

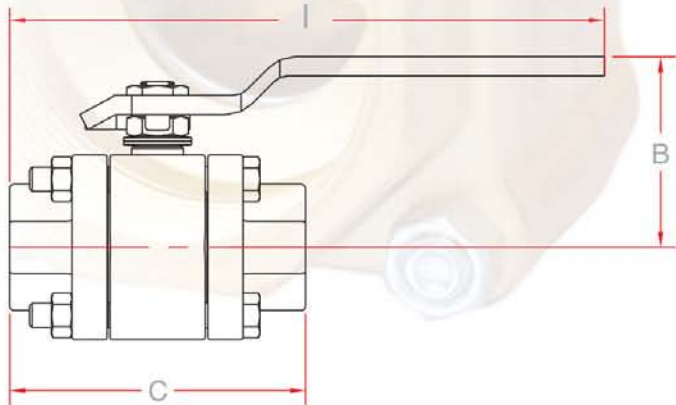
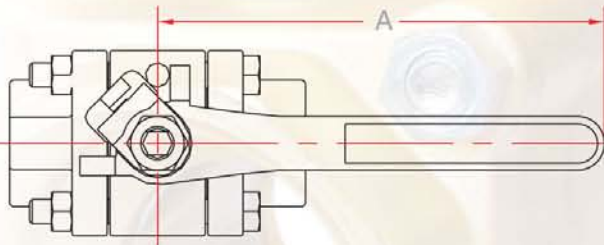
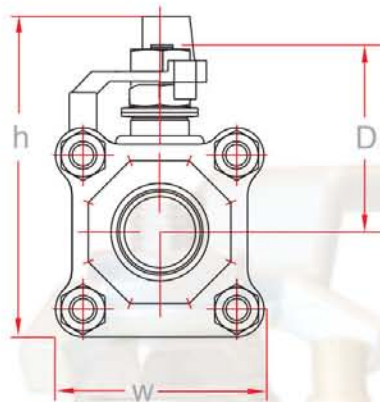

Serie 400 (Latón) Paso reducido • Series 400 (Brass) Reduced bore

Medida / Size	A	B	C	D	Paso Bore	Peso / Weight		l Largo / Length	h Altura / Height	W Ancho / Width
						kg	lb			
1/4	4.30	1.69	2.61	1.50	.430	0.630	1.300	5.56	2.57	1.79
3/8	4.30	1.75	2.61	1.50	.450	0.620	1.300	5.56	2.65	1.79
1/2	4.30	1.58	2.61	1.50	.450	0.590	1.300	5.56	2.50	1.79
3/4	4.30	1.87	2.83	1.50	.560	0.750	1.600	5.74	2.72	2.00
1	5.84	2.21	3.69	2.19	.810	1.460	3.200	7.69	3.58	2.45
1 1/4	5.75	2.76	4.16	2.35	1.000	2.010	4.400	7.81	3.96	2.63
1 1/2	7.00	3.02	4.56	2.89	1.250	2.940	6.480	9.28	4.51	3.06
2	7.00	3.21	4.94	3.13	1.500	4.010	8.800	9.52	5.00	3.48

Serie 400 (Latón) Paso completo • Series 400 (Brass) Full bore

Medida / Size	A	B	C	D	Paso Bore	Peso / Weight		l Largo / Length	h Altura / Height	W Ancho / Width
						Kg	lb			
1/4	4.30	1.75	2.61	1.50	.450	0.620	1.300	5.56	2.65	1.79
3/8	4.30	1.58	2.61	1.50	.450	0.590	1.300	5.56	2.50	1.79
1/2	4.30	1.87	2.83	1.50	.560	0.750	1.600	5.74	2.72	2.00
3/4	5.84	2.21	3.69	2.19	.810	1.460	3.200	7.69	3.58	2.45
1	5.75	2.76	4.16	2.35	1.000	2.010	4.400	7.81	3.96	2.63
1 1/4	7.00	3.02	4.56	2.89	1.250	2.940	6.480	9.28	4.51	3.06
1 1/2	7.00	3.21	4.94	3.13	1.500	4.010	8.800	9.52	5.00	3.48

Nota: Dimensiones en pulgadas • Note: All dimensions in inch

SERIES 600 REDUCE and FULL BORE



Ball valve three-piece design, available in sizes from 1/4" to 2", strong construction in carbon and stainless steel.
Connections: NPT, BSPP, BSPT, SW, BW.
Stem seals for frequent cycles.

Válvula de bola, diseño de 3 piezas, en medida de 1/4" a 2". Construcción robusta en materiales de acero al carbón y acero inoxidable.
Conexiones: NPT, BSPP, BSPT, SW, BW.
Sellos del Vástago para ciclos frecuentes.

Válvula Valve	ANSI B16.34 Clase • Class	Acero al Carbón • Carbon Steel		Acero Inoxidable • Stainless Steel	
		Presión de Trabajo Working Pressure	Presión Max. de Prueba Max. Test Pressure	Presión de Trabajo Working Pressure	Presión Max. de Prueba Max. Test Pressure
Serie 600 • Series 600	600	1480 psi	2225 psi	1440 psi	2175 psi
Serie 600 Paso Completo • Series 600 Full Bore	900	2220 psi	3350 psi	2160 psi	3250 psi

OPCIONES:

Diversos materiales para sellos y asientos. Dispositivo para candado, Cuerpo conforme a la norma ISO 5211 (excepto 2" Paso completo, en donde se tiene diseño del cuerpo para adaptación de soporte en trabajo de Automatización). Enchafetado para control térmico, maneral oval, libre de grasa, vástago extendido, vástago antiestático, Automatización con actuador eléctrico ó neumático. A prueba de fuego cumple con normativa API 607, API 6D.

OPTIONS:

Diversity in materials for seals and seats, locking device, Body design according to ISO 5211 (except on 2" where special body design for coupling bracket on automation job). oval handle oil free, 3 ways / diverter, cryogenic, antistatic stem, extended stem.
In Acordance with API 6D.

The valve can be automated with an electric or pneumatic actuator.

Lista de partes
List of components

- 1 Tornillo del cuerpo • Body bolt
- 2 Tapa • Pipe end
- 3 Sello de cuerpo • Body seal
- 4 Asiento • Seat
- 5 Bola • Ball
- 6 Cuerpo • Body
- 7 Tuerca del cuerpo • Body nut
- 8 Vástago • Stem
- 9 Roldana inferior de vástago • Thrust bearing
- 10 Sello de vástago • Stem seal
- 11 Separador • Stem follower
- 12 Roldana cóncava • Belleville washer
- 13 Tuerca de vástago • Retaining nut
- 14 Seguro para tuerca • Lock nut
- 15 Maneral • Handle
- 16 Dispositivo para candado • Locking device

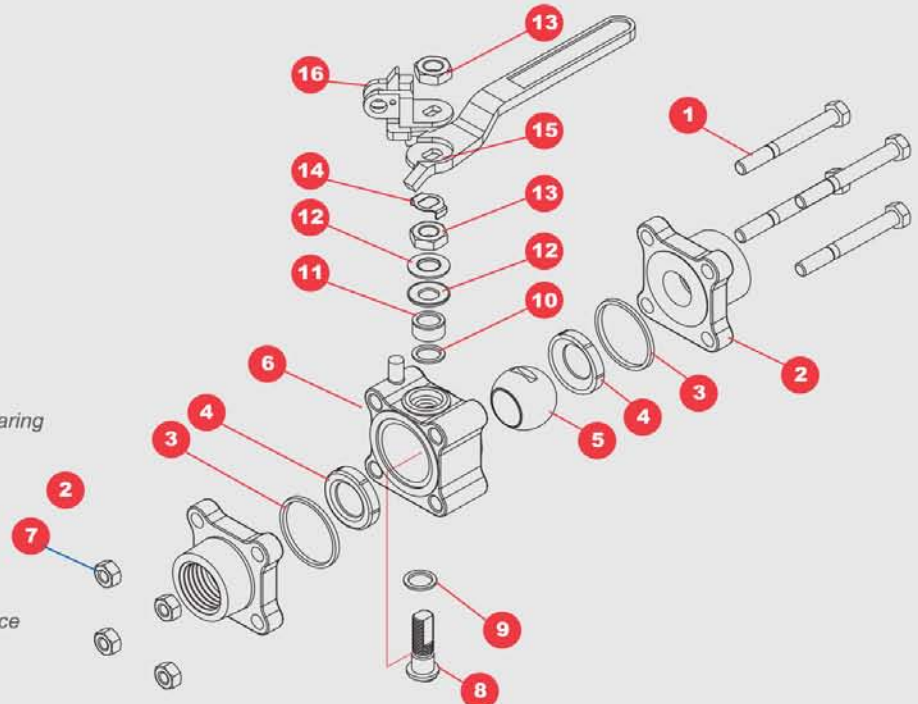

SERIES 600 REDUCE and FULL BORE

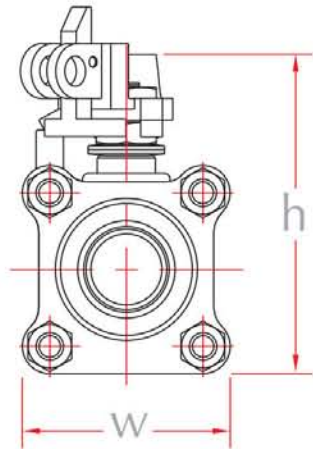

Serie 600 Materiales de sellos y asientos
Series 600 Seal and seat materials

Asiento Seat	Sello del cuerpo Body seal	Sello del vástago Stem seal
*R R-PTFE	B - BUNA	*R R-PTFE
M MULTIFIL	*T - PTFE	
I PTFE + INOX.	M - MULTIFIL	
Y DELRIN	V - VITON	*M MULTIFIL
U UHMWPE	G - GRAFOIL	
P PEEK		

* Materiales estandar / Standard materials

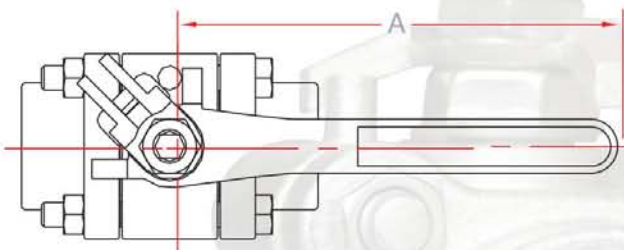

Serie 600 Paso reducido • Series 600 Reduced bore

Medida / Size	A	B	C	D	Paso Bore	Peso / Weight		l	h	w
						kg	lb	Largo / Length	Altura / Height	Ancho / Width
1/2	4.25	1.69	2.61	1.51	.440	0.590	1.300	5.56	2.65	1.75
3/4	4.25	1.77	2.83	1.61	.560	0.750	1.600	5.67	2.77	2.00
1	5.75	2.33	3.72	2.17	.810	1.460	3.200	7.66	3.50	2.38
1 1/4	5.75	2.50	4.22	2.35	1.000	2.010	4.400	7.86	3.71	2.63
1 1/2	7.00	3.02	4.56	2.80	1.250	3.330	7.300	9.28	4.62	3.19
2	7.00	3.21	5.01	3.07	1.500	4.550	10.030	9.51	5.00	3.57

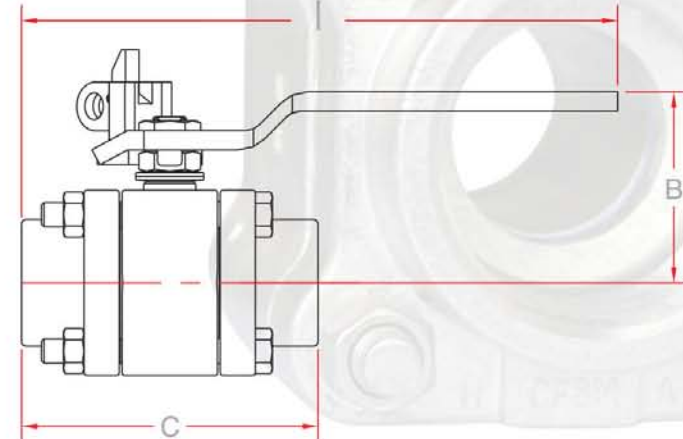

Serie 600 Paso completo • Series 600 Full bore

Medida / Size	A	B	C	D	Paso Bore	Peso / Weight		l	h	w
						kg	lb	Largo / Length	Altura / Height	Ancho / Width
1/2	4.25	1.77	2.83	1.61	.560	0.750	1.600	5.67	2.77	2.00
3/4	5.75	2.33	3.72	2.17	.810	1.460	3.200	7.66	3.50	2.38
1	5.75	2.50	4.22	2.35	1.000	2.010	4.400	7.86	3.71	2.63
1 1/4	7.00	3.02	4.56	2.80	1.250	3.330	7.300	9.28	4.62	3.19
1 1/2	7.00	3.21	5.01	3.07	1.500	4.550	10.030	9.51	5.00	3.57
2	7.42	4.84	5.87	4.68	2.000	9.400	20.700	10.29	6.56	4.55

Nota: Dimensiones en pulgadas • Note: All dimensions in inch



Válvula de bola, diseño de 3 piezas Clase 300 en Medidas de 2 1/2", 3", 4" y 6". Construcción robusta en materiales de acero al carbón y acero inoxidable. Base ISO 5211 estandar para conexiones: NPT, BSPP, BSPT, SW, BW.

Ball valve, three-piece design, reduced bore, class ANSI 300, available in 2 1/2", 3", 4", and 6". Strong construction in carbon and stainless steel. Stem seals for frequent cycles in various materials. ISO Plate 5211 for automation. Connections: NPT, BSPP, BSPT, SW, BW.

Válvula Valve	ANSI B16.34 Clase • Class	Acero al Carbón • Carbon Steel		Acero Inoxidable • Stainless Steel	
		Presión de Trabajo Working Pressure	Presión Max.de Prueba Max. Test Pressure	Presión de Trabajo Working Pressure	Presión Max.de Prueba Max. Test Pressure
Serie 45 • Series 45	300	740 psi	1125 psi	720 psi	1100 psi

OPCIONES:

Válvula enchaquetada para control térmico, válvula con conexión clamp en medidas 2 1/2", 3" y 4". Válvula criogénica en 2 1/2", 3", 4" y 6" libre de grasa, vástago antiestático, dispositivo para candado, automatización con actuador eléctrico ó neumático. A prueba de fuego y cumple con normatividad API 607.

OPTIONS:

Jacketed valve for thermic control, clamp connections in 2 1/2", 3" and 4", cryogenic valve in 2 1/2", 3", 4", and 6" oil free, antistatic device, locking device. The valve can be automated with an electric or pneumatic actuator.

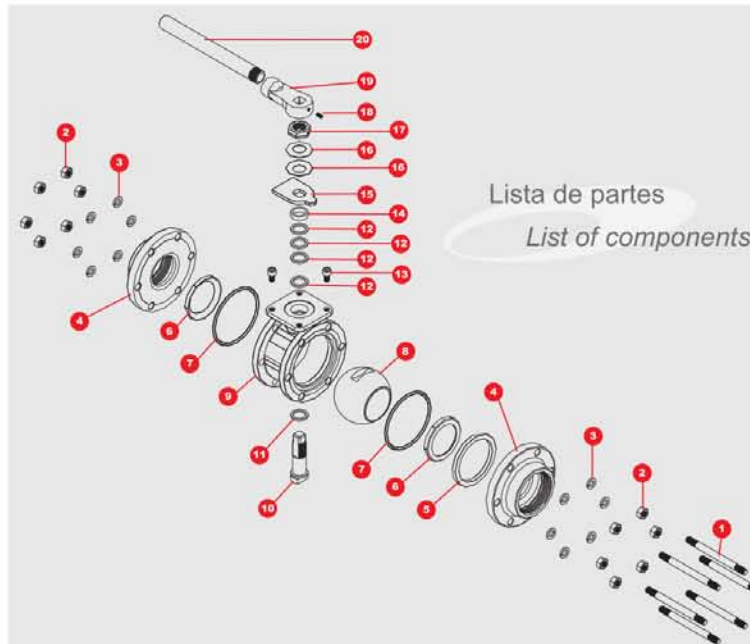

Lista de partes
List of components

- 1 Birlo • Stud
- 2 Tuerca del cuerpo • Body nut
- 3 Roldana de presión • Lock washer
- 4 Tapa • Pipe end
- 5 Anillo centrante • Seat retainer
- 6 Asiento • Seat
- 7 Sello de cuerpo • Body seal
- 8 Bola • Ball
- 9 Cuerpo • Body
- 10 Vástago • Stem
- 11 Roldana inferior de vástago • Thrust bearing
- 12 Sello de vástago • Stem seal
- 13 Tornillo tope • Stop screw
- 14 Separador • Stem follower
- 15 Placa tope • Stop plate
- 16 Roldana cóncava • Belleville washer
- 17 Tuerca de vástago • Retaining nut
- 18 Opresor del maneral • Handle screw
- 19 Maneral • Handle
- 20 Palanca • Wrench extension

SERIES 45 REDUCE and FULL BORE

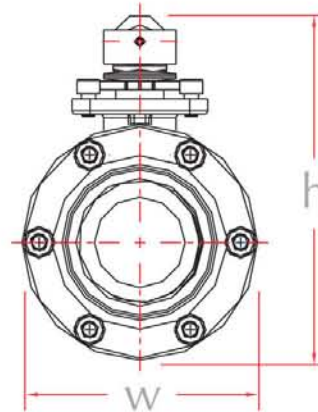

Dimensiones • Dimensions

ISO 5211	
2 1/2	F07
3	F10
4	F10
6	F12

Serie 45 Materiales de sellos y asientos
Series 45 Seal and seat materials

Asiento Seat	Sello del cuerpo Body seal	Sello del vástago Stem seal
B BUNA	* B - BUNA	
* T PTFE	T - PTFE	* R R-PTFE
R R-PTFE	M - MULTIFIL	
M MULTIFIL	V - VITON	
I PTFE + INOX.	G - GRAFOIL	
Y DELRIN		M MULTIFIL
U UHMWPE		
P PEEK		

* Materiales estandar / Standard materials

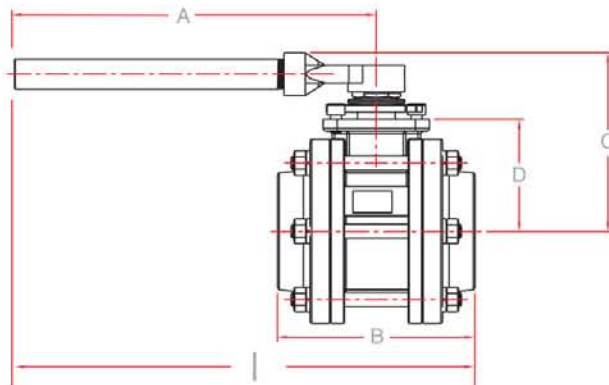

Serie 45 Paso reducido
Series 45 Reduced bore

Medida / Size	A	B	C	D	Paso Bore	Peso / Weight		l	h	w
						kg / lb	Largo / Length	Altura / Height	Ancho / Width	
2 1/2	7.35	5.94	4.41	3.06	2.000	10.420	23.300	10.34	7.29	5.87
3	22.5	6.86	6.17	3.98	2.500	15.870	36.500	26.43	9.42	6.50
4	22.5	8.62	6.23	4.58	3.250	29.000	62.600	27.32	10.80	8.10
6	22.5	11.75	9.13	6.19	4.370	80.100	176.300	22.50	14.69	11.12

Nota: Dimensiones en pulgadas • Note: All dimensions in inch

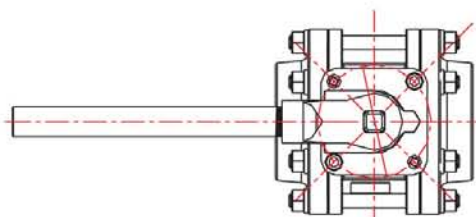

Serie 45 Paso completo
Series 45 Full bore

Medida / Size	A	B	C	D	Paso Bore	Peso / Weight		l	h	w
						kg / lb	Largo / Length	Altura / Height	Ancho / Width	
2 1/2	3.35	6.86	6.17	3.98	2.500	15.870	36.500	26.43	9.42	6.50
3	22.5	8.62	6.23	4.58	3.250	29.000	62.600	27.32	10.80	8.10
4	22.5	11.75	9.13	6.19	4.370	80.100	176.300	22.50	14.69	11.12

Nota: Dimensiones en pulgadas • Note: All dimensions in inch

SERIES 15 REDUCE BORE



Válvula de bola bridada, Clase 150 cuerpo de una pieza con tapón rosca-do. Construcción ligera en materiales de acero al carbón y acero inoxidable, en medidas de 1" a 6". Sellos del vástago para ciclos frecuentes tipo chevron.

Maneral con provisión para candado, vástago con dispositivo antiestático. Plato ISO 5211 para automatización. Diseño de maneral corto para operar la válvula con palanca en medidas de 3" a 6".

Ball valve, one-piece design, flanged, Class 150 with threaded plug, available from 1" to 6", light construction in carbon stainless steels, chevron type stem seals for frequent cycles in several materials, handle with locking device, stem with antistatic device, plate ISO 5211 for direct mounting of actuators, and short handle design for operation with lever in sizes from 3" to 6".

* Materiales estandar Standard materials

Válvula Valve	ANSI B16.34 Clase • Class	Acero al Carbón • Carbon Steel		Acero Inoxidable • Stainless Steel	
		Presión de Trabajo Working Pressure	Presión Max.de Prueba Max. Test Pressure	Presión de Trabajo Working Pressure	Presión Max.de Prueba Max. Test Pressure
Serie 15 • Series 15	150	285 psi	450 psi	275 psi	425 psi

Diseño de 1" a 2 1/2" 1" to 2 1/2" design

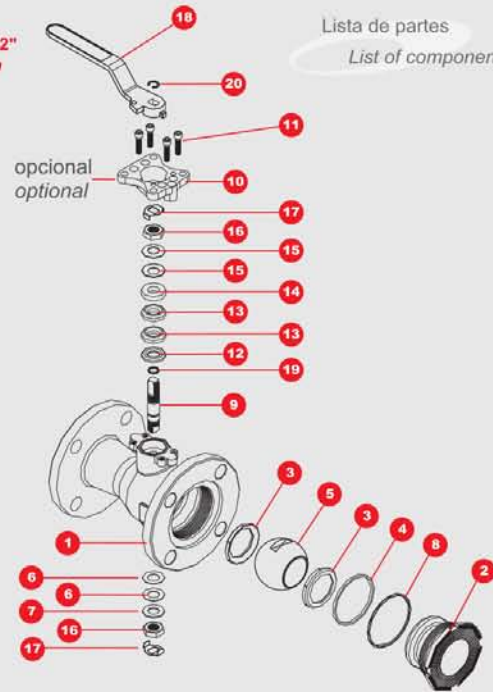

Lista de partes List of components

- | | |
|--|---|
| 1 Cuerpo • Body | 11 Tornillo plato ISO • ISO pad screw |
| 2 Tapón • Plug | 12 Seguidor inferior • Thrust bearing |
| 3 Asiento • Seat | 13 Empaque tipo chevron • Chevron type seal |
| 4 Sello de cuerpo • Body seal | 14 Seguidor superior • Follower |
| 5 Bola • Ball | 15 Roldana cóncava • Belleville washer |
| 6 Sello de vástago • Stem seal | 16 Tuerca de vástago • Stem nut |
| 7 Roldana de retención • Retainer washer | 17 Seguro para tuerca • Lock nut |
| 8 O-ring • O-ring | 18 Maneral • Handle |
| 9 Vástago • Stem | 19 Aro sello de vástago • Stem O-ring |
| 10 Plato ISO 5211 • ISO pad 5211 | 20 Seguro de maneral • Handle lock |

Diseño de 3" a 6" 3" to 6" design

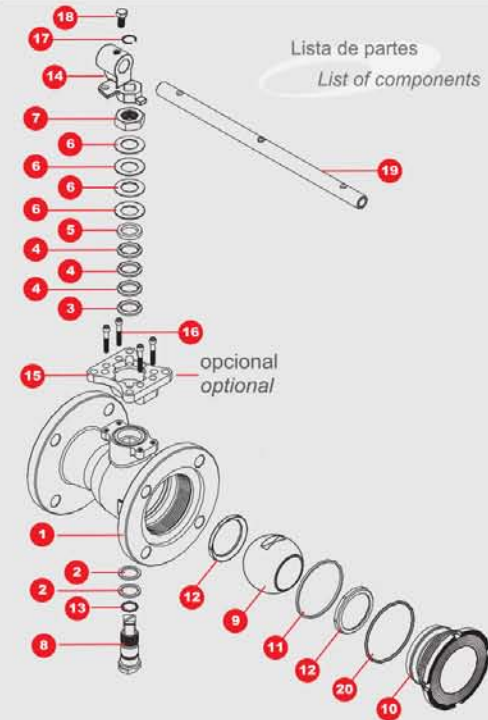

Lista de partes List of components

- | | |
|--|--|
| 1 Cuerpo • Body | 11 Sello de cuerpo • Body seal |
| 2 Sello de vástago • Stem seal | 12 Asiento • Seat |
| 3 Seguidor inferior • Thrust bearing | 13 O-ring • O-ring |
| 4 Empaque Tipo chevron • Type chevron seal | 14 Maneral • Handle |
| 5 Seguidor superior • Follower | 15 Plato ISO 5211 • ISO pad 5211 |
| 6 Roldana cóncava • Belleville washer | 16 Tornillo plato ISO • ISO pad screw |
| 7 Tuerca autotrabante • Stem nut | 17 Seguro • lock |
| 8 Vástago • Stem | 18 Tornillo del maneral • Handle screw |
| 9 Bola • Ball | 19 Extensión de maneral • Handle extension |
| 10 Tapón • Plug | 20 Aro sello de cuerpo • Body O-ring |

SERIES 15 REDUCE BORE

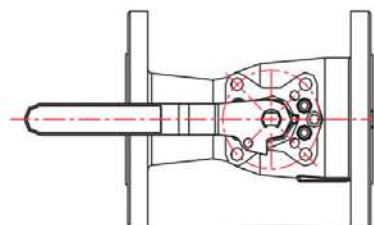
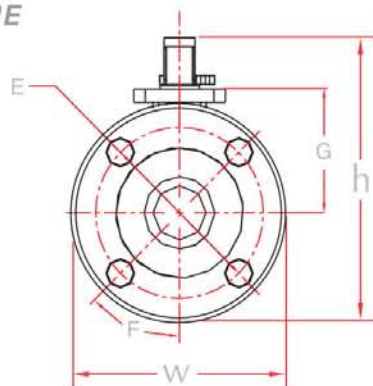

Dimensiones • Dimensions

Diseño de 1" a 2 1/2"
1" to 2 1/2" Design

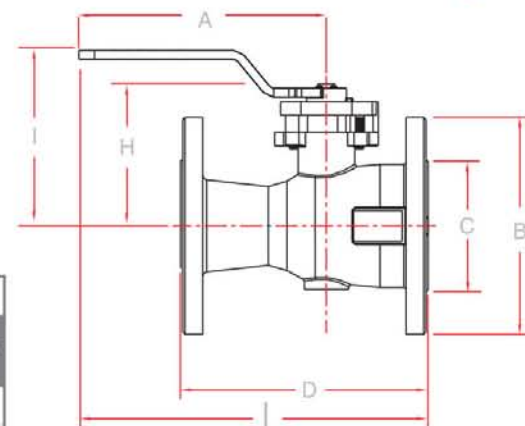

Serie 15 • Series 15

Medida / Size	A	B	C	D	E	F	G	H	I	Paso Bore	Peso / Weight		l	h	W
											kg	lb			
1	5.81	4.25	2.00	5.00	3.13	45°	2.16	2.77	3.21	.750	2.400	5.290	7.74	5.41	4.25
1 1/2	7.13	5.00	2.88	6.50	3.82	45°	3.10	3.51	4.43	1.130	4.590	10.120	9.50	6.98	5.00
2	7.14	6.00	3.62	7.00	4.75	45°	3.29	3.69	4.67	1.500	7.500	16.530	10.02	7.65	6.00
2 1/2	7.09	7.00	4.12	7.53	5.50	45°	3.79	4.15	5.20	2.000	11.500	25.350	10.35	8.70	7.00

Nota: Dimensiones en pulgadas • Note: All dimensions in inch

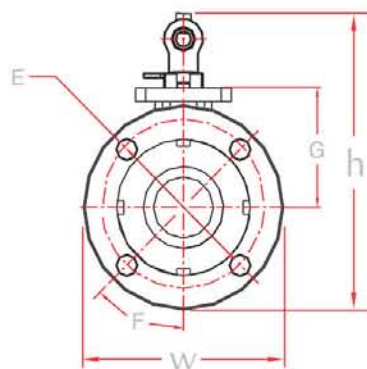
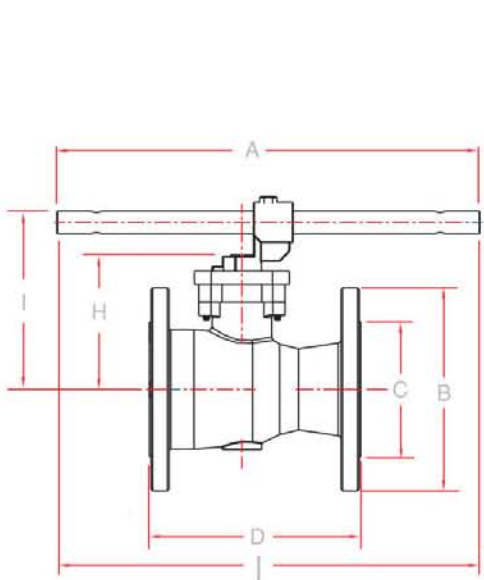

Diseño de 3" a 6"
3" to 6" Design

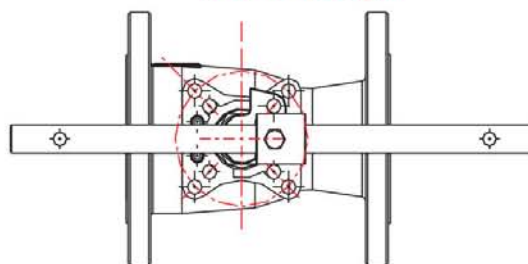

Dimensiones • Dimensions

ISO 5211	
1	F05
1 1/2	F07
2	F07
2 1/2	F07
3	F10
4	F10
6	F12/F14

Serie 15 • Series 15

Medida / Size	A	B	C	D	E	F	G	H	I	Paso Bore	Peso / Weight		l	h	W
											kg	lb			
3	16.0	7.50	5.00	8.00	6.00	45°	4.40	4.80	6.50	2.300	14.500	32.000	16.00	10.30	7.50
4	16.0	9.00	6.20	9.00	7.50	22.5°	5.10	5.50	7.10	3.00	25.400	56.000	16.00	11.80	9.00
6	20.0	11.00	8.50	10.50	9.50	22.5°	6.40	7.00	8.90	4.00	41.000	90.400	20.00	15.00	11.00

Nota: Dimensiones en pulgadas • Note: All dimensions in inch

SERIES 150/300 REDUCE BORE



Válvula de bola bridada en paso reducido, clases 150 y 300 construcción robusta en materiales de acero al carbón y acero inoxidable, sellos del vástago para ciclos frecuentes en diversos materiales.

Diseño de cuerpo de 3 piezas en medidas de 1/2" a 2", clase 150 y 300.

Diseño de cuerpo de 1 pieza con tapon roscado en medidas de 3" a 10" en clase 150 y en medidas de 3" a 8" en clase 300, base ISO 5211 estándar de 3 a 8" (excepto en 10").

Diseño de maneral corto para operar la válvula con palanca, en medidas de 3" y mayores (para serie 150 y serie 300).

Three piece design valve, available in sizes from 1/2" to 2" ANSI 150 / 300 and 1 piece design with screwed cap in sizes from 3" to 10" ANSI 150 and from 3" to 10" ANSI 300. ISO Pad 5211 as standard in sizes from 3" to 8" (exception 10").

Short-handle, designed for operating the valve with lever. From size 3" and up.

OPCIONES:

- Diversos materiales de sellos y asientos.
- Dispositivo para candado.
- Vástago antiestático.
- Cuerpo ISO de acuerdo a ISO 5211 (en medidas de 1/2" a 2").
- 3 vías (en medida de 1/2" a 2").
- Libre de grasa.
- Maneral oval (en medidas de 1/2" a 2").
- Extensión del vástago (en medidas de 1/2" a 2").
- Automatización con actuadores eléctricos ó neumáticos.



OPTIONS:

- Diversity in materials for seats and seals*
- Locking device*
- Antistatic device*
- Body ISO according to ISO 5211 (in sizes from 1/2" to 2")*
- 3 ways (in sizes from 1/2" to 2") Oil free*
- Oval handle (in sizes from 1/2" to 2")*
- Stem extension (in sizes from 1/2" to 2")*
- The valve can be automated with an electric or pneumatic actuator.*

Serie 150/300 Materiales de sellos y asientos

Serie 150/300 Seat and seal materials

Asiento Seat	Sello del cuerpo Body seal	Sello del vástago Stem seal
B BUNA	B - BUNA	
T PTFE	* T - PTFE	* R R-PTFE
R R-PTFE	M - MULTIFIL	
M MULTIFIL	V - VITON	
I PTFE + INOX.	G - GRAFOIL	
Y DELRIN		M MULTIFIL
U UHMWPE		
P PEEK		

* Materiales estandar / Standard materials

Válvula Valve	ANSI B16.34 Clase • Class	Acero al Carbón • Carbon Steel ASTM A216 WCB		Acero Inoxidable • Stainless Steel ASTM A351 CF8M	
		Presión de Trabajo Working Pressure	Presión Max.de Prueba Max. Test Pressure	Presión de Trabajo Working Pressure	Presión Max.de Prueba Max. Test Pressure
Serie 150 • Series 150	150	285 psi	450 psi	275 psi	425 psi
Serie 300 • Series 300	300	740 psi	1125 psi	720 psi	1100 psi

SERIES 150/300 REDUCE BORE

Serie 150/300 (1/2" a 2")
Series 150 /300 (1/2" to 2")

Lista de partes
List of components

- 1 Tuerca del cuerpo • *Body nut*
- 2 Tapa Brida • *Flanged Cover*
- 3 Asiento • *Seat*
- 4 Sello de cuerpo • *Body seal*
- 5 Bola • *Ball*
- 6 Cuerpo • *Body*
- 7 Birlo del cuerpo • *Body bolt*
- 8 Vástago • *Stem*
- 9 Roldana inferior de vástago • *Thrust bearing*
- 10 Roldana superior de vástago • *Stem seal*
- 11 Separador • *Follower*
- 12 Roldana cóncava • *Belleville washer*
- 13 Tuerca de vástago • *Stem nut*
- 14 Seguro para tuerca de vástago • *Nut Lock*
- 15 Maneral • *Handle*
- 16 Dispositivo para candado (opcional) • *Locking device (optional)*

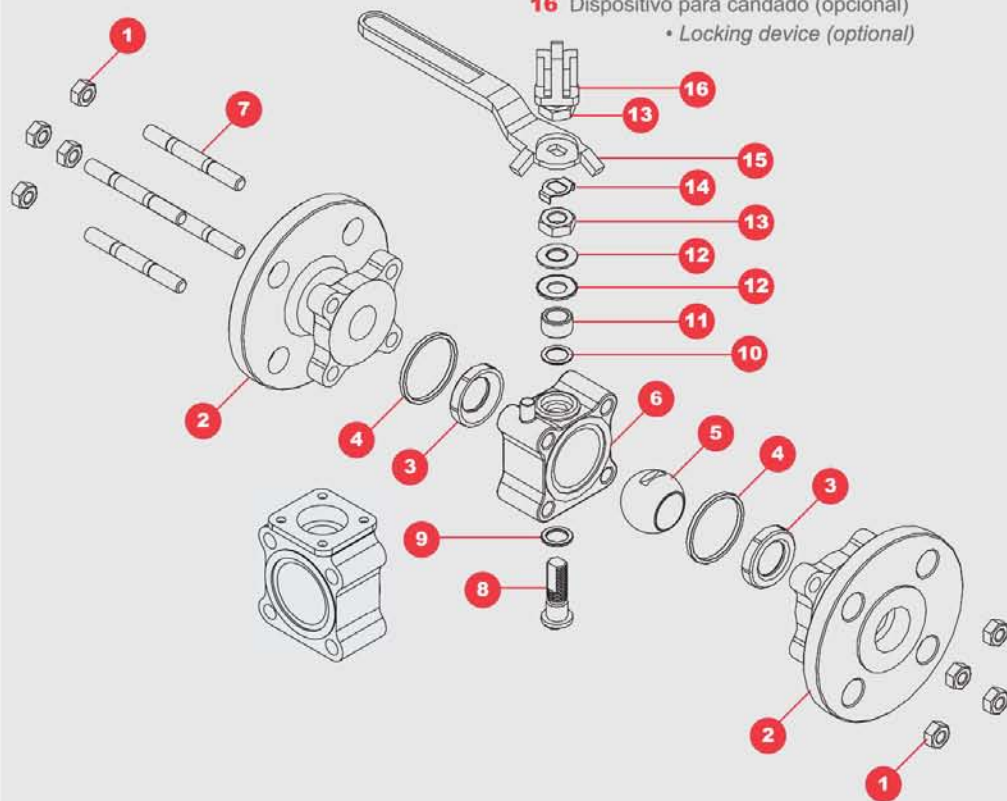

Serie 150 (3" a 10") Serie 300 (3" a 8")
Series 150 (3" to 10") Series 300 (3" to 8")

- 1 Tapón • *Plug*
- 2 Sello de cuerpo • *Body seal*
- 3 Asiento • *Seat*
- 4 Bola • *Ball*
- 5 Cuerpo 150 • *Body 150*
- 5a Cuerpo 300 • *Body 300*
- 6 Vástago • *Stem*
- 7 Roldana de vástago • *Thrust bearing*
- 8 Sello de vástago • *Stem seal*
- 9 Separador • *Stem follower*
- 10 Placa tope • *Stop plate*
- 11 Roldana cóncava • *Belleville washer*
- 12 Tuerca autotrabante • *Retaining nut*
- 13 Maneral • *Handle*
- 14 Tornillo tope • *Stop screw*
- 15 Palanca • *Lever*
- 16 Opresor para maneral • *Handle screw*

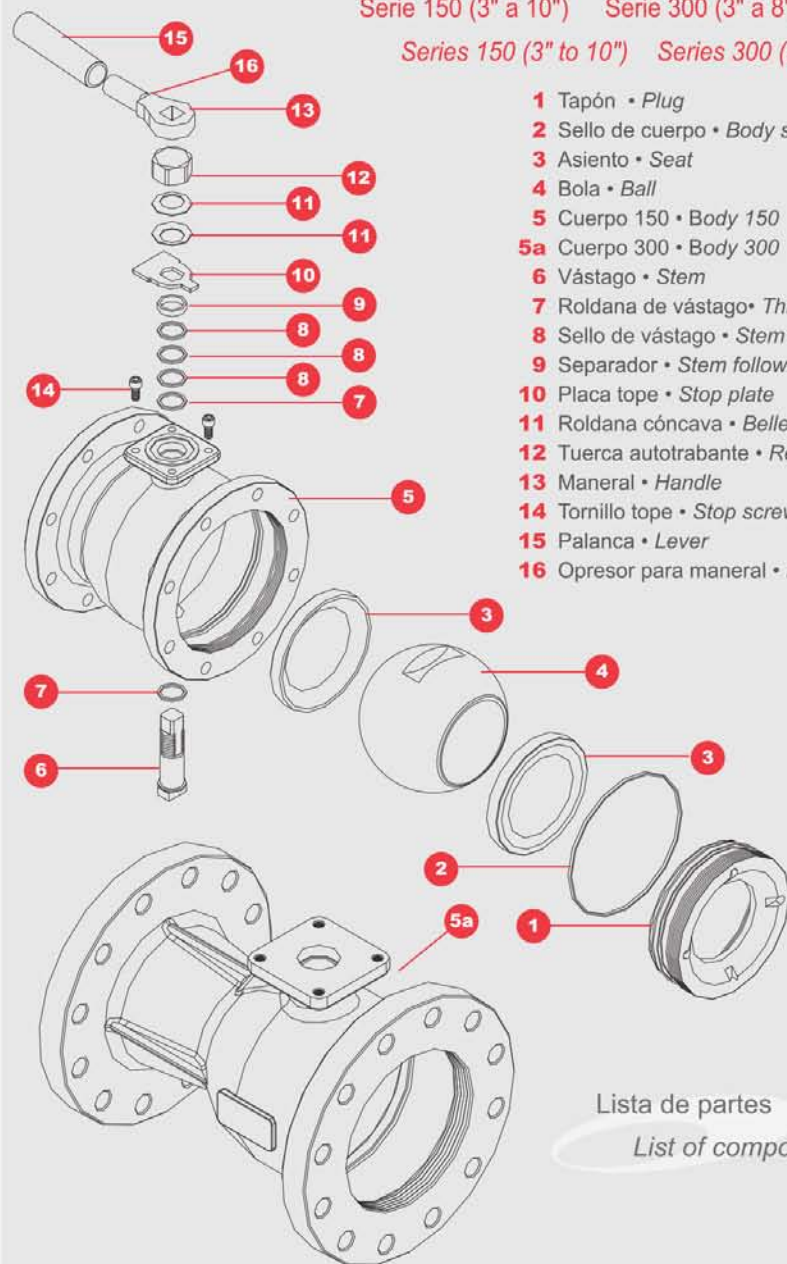

Lista de partes
List of components

SERIE 150/300 REDUCE BORE



Serie 150 • Series 150

Medida / Size	A	B	C	D	E	F	G	Paso Bore	Peso / Weight		Largo / Length	h	W
									kg	lb			
1/2	4.35	2.70	4.27	3.64	1.46	2.38	45°	.440	1.600	3.500	6.53	4.50	3.61
3/4	4.95	2.58	4.65	3.98	1.60	2.75	45°	.560	2.100	4.600	6.83	4.57	3.98
1	4.85	3.61	5.03	4.37	2.17	3.12	45°	.810	3.230	7.120	8.37	5.78	4.37
1 1/2	7.15	4.27	6.50	5.13	2.88	3.58	45°	1.250	6.710	14.790	10.43	6.77	5.13
2	7.20	4.40	7.00	6.13	3.07	4.75	45°	1.500	9.170	20.700	10.71	7.40	6.13

Nota: Dimensiones en pulgadas • Note: All dimensions in inch

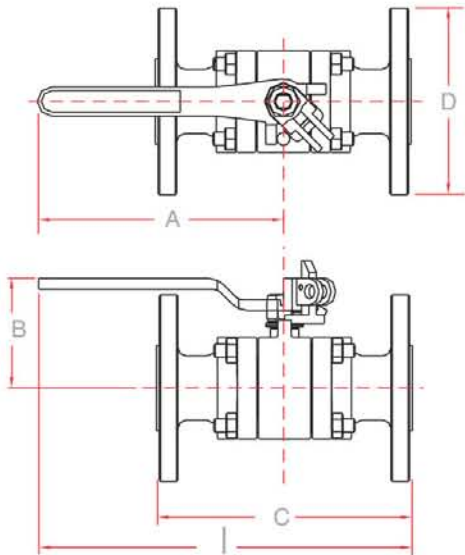

Serie 300 (1/2" a 2")
Series 300 (1/2" to 2")

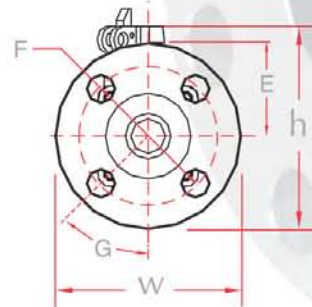

Serie 150 (1/2" a 2")

Series 150 (1/2" to 2")

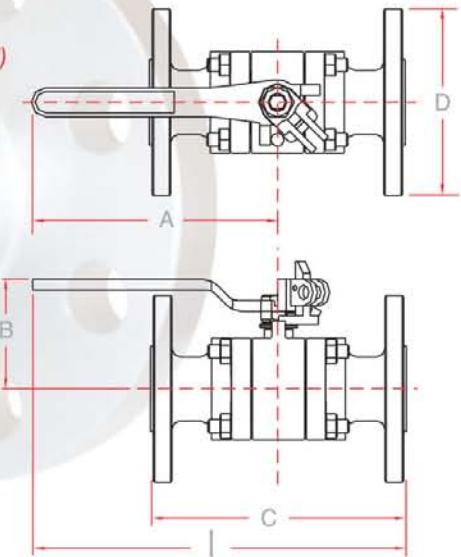

Serie 300 • Series 300

Medida / Size	A	B	C	D	E	F	G	Paso Bore	Peso / Weight		Largo / Length	h	W
									kg	lb			
1/2	4.25	2.72	5.54	3.75	1.46	2.62	45°	.440	2.060	4.540	7.00	4.60	3.75
3/4	4.25	2.78	6.00	4.62	1.57	3.25	45°	.560	3.100	7.000	7.25	5.34	4.62
1	5.85	3.45	6.50	4.88	2.17	3.50	45°	.810	4.490	9.900	9.08	5.90	4.88
1 1/2	7.00	4.27	7.59	6.12	2.88	4.47	45°	1.250	9.600	21.160	10.81	7.35	6.12
2	7.12	4.39	8.50	6.50	3.07	5.00	45°	1.500	11.370	24.070	11.42	7.64	6.50

Nota: Dimensiones en pulgadas • Note: All dimensions in inch



SERIES 150/300 REDUCE BORE

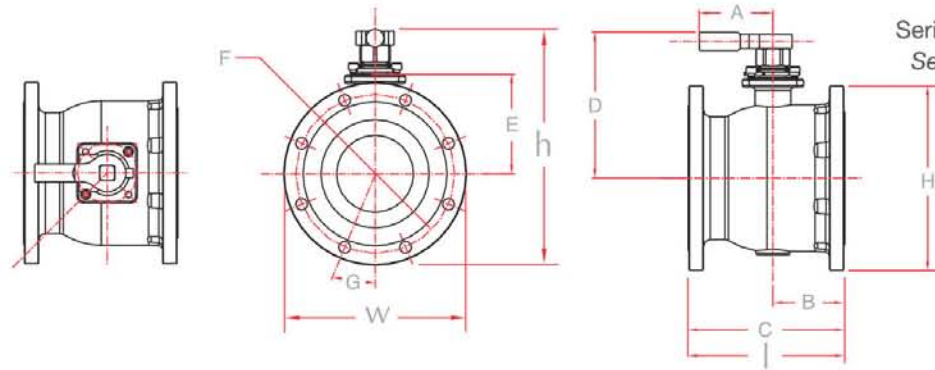

Serie 150 (3" a 10")
Series 150 (3" a 10")

ISO 5211	
3	F10
4	F10
6	F12
8	F12
10	F14

Serie 150 • Series 150

Medida / Size	A	B	C	D	E	F	G	H	Paso Bore	Peso / Weight		Largo / Length	h	w
										kg	lb			
3"	3.25	3.62	8.00	6.15	3.88	6.00	45°	7.50	2.500	19.000	43.600	8.00	9.80	7.50
4"	3.25	3.99	9.00	6.74	4.48	7.50	22.5°	9.00	3.250	30.400	67.000	9.00	11.25	9.00
6"	4.34	4.21	10.50	9.192	6.19	9.50	22.5°	11.00	4.370	48.200	106.200	10.50	14.67	11.00
8"	4.34	5.11	11.50	10.20	7.28	11.75	22.5°	13.50	5.680	77.400	170.600	11.50	16.95	13.50
10"	4.00	7.12	13.00	12.84	9.47	14.00	15°	16.00	7.370	122.000	268.900	13.00	20.85	16.00

Nota: Dimensiones en pulgadas • Note: All dimensions in inch

Serie 300 (3" a 10")
Series 300 (3" a 8")

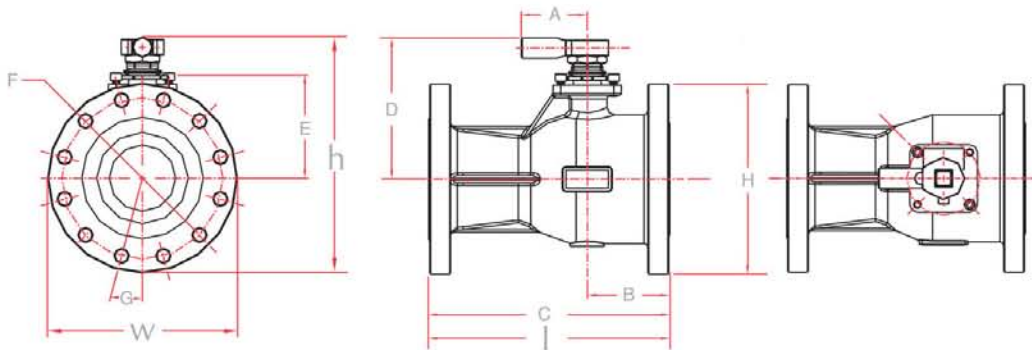

ISO 5211	
3	F10
4	F10
6	F12
8	F12

Serie 300 • Series 300

Medida / Size	A	B	C	D	E	F	G	H	Paso Bore	Peso / Weight		Largo / Length	h	w
										kg	lb			
3"	3.25	4.27	11.12	6.14	3.88	6.62	22.5°	8.25	2.500	23.600	52.030	11.12	10.27	8.25
4"	3.25	4.72	12.00	6.75	4.48	7.88	22.5°	10.00	3.250	38.000	183.700	12.09	11.75	10.00
6"	4.34	5.50	15.88	9.26	6.19	10.62	15°	12.50	4.370	69.000	152.140	15.88	15.50	12.50
8"	4.34	8.19	16.50	10.33	7.43	13.00	15°	15.00	5.680	122.000	269.010	16.50	17.83	15.00

Nota: Dimensiones en pulgadas • Note: All dimensions in inch





SERIE 152/302 FULL BORE

Válvula Valve	ANSI B16.34 Clase • Class	Acero al Carbón • Carbon Steel		Acero Inoxidable • Stainless Steel	
		Presión de trabajo Working pressure	Presión Máx. de prueba Max. Test pressure	Presión de trabajo Working pressure	Presión Máx. de prueba Max. Test pressure
Serie 152 • Series 152	150	285 psi	450 psi	275 psi	425 psi
Serie 302 • Series 302	300	740 psi	1125 psi	720 psi	1100 psi

Válvula de bola de paso completo, bridada, clase 150 y 300. Construcción robusta en materiales de Acero al Carbón y Acero Inoxidable.

En serie 152, diseño de cuerpo de 2 piezas en medidas de 1/2" a 8" clase 150. En serie 302 de 2 a 6" clase 300. Doble sello y sello Tipo "V" en caja de vástago para ciclos frecuentes, maneral con provisión para candado y vástago antiestático. Plato ISO 5211.

Diseño de maneral corto para operar la válvula con palanca (de 3" a 8").

Ball valve, 2-piece design, full bore, flanged, in classes ANSI 150/300. Strong construction in carbon and Stainless Steel. these valves are available in Series 152 from 1/2" to 8" and in Series 302 from 2" to 6". Double seal and seat tipe "V" in stem box for frequent cycles in adversity of materials. ISO Plate 5211.

Handle with locking device, antistatic stem, short handle for operating the valve with a lever (from 3" to 8")

OPCIONES

Diversos materiales de sellos y asientos, libre de grasa, de acuerdo con API 6D. Automatización con actuadores eléctricos y neumáticos.

OPTIONS

Diversity of seal and seat materials, oil free, in accordance with API 6D. Automation with electric and pneumatic actuators.

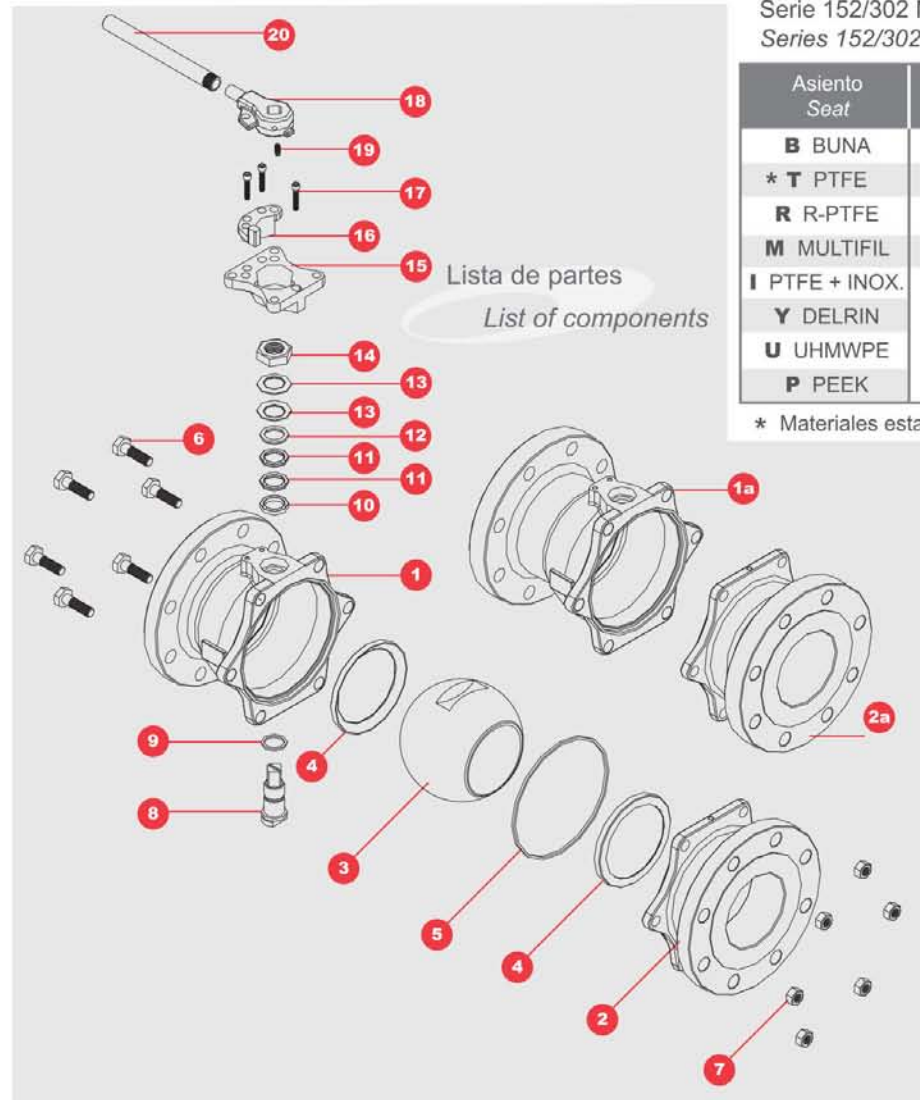

Lista de partes
List of components

Serie 152/302 Materiales de asiento y sello
Series 152/302 Seat and seal materials

Asiento Seat	Sello del cuerpo Body seal	Sello del vástago Stem seal
B BUNA	B - BUNA	
* T PTFE	* T - PTFE	* R R-PTFE
R R-PTFE	M - MULTIFIL	
M MULTIFIL	V - VITON	
I PTFE + INOX.	G - GRAFOIL	
Y DELRIN		M MULTIFIL
U UHMWPE		
P PEEK		

* Materiales estandar / Standard materials

- 1 Serie 152 • Series 152 Body
- 1a Serie 302 • Series Body 302
- 2 Serie 152 • Series Cover 152
- 2a Serie 302 • Series Cover 302
- 3 Bola • Ball
- 4 Asiento • Seat
- 5 Sello de cuerpo • Body seal
- 6 Tornillos del cuerpo • Body bolts
- 7 Tuercas del cuerpo • Body nuts
- 8 Vástago • Stem
- 9 Sello de vástago • Stem seal
- 10 Seguidor inferior • Thrust bearing
- 11 Empaque chevron • Chevron seal
- 12 Seguidor superior • Follower
- 13 Roldana cóncava • Belleville washer
- 14 Tuerca autotrabante • Stem nut
- 15 Base ISO (opcional) • ISO base (optional)
- 16 Dispositivo para candado • Locking device
- 17 Tornillos de la base • Screw base
- 18 Maneral • Handle
- 19 Prisionero • Set screw
- 20 Palanca • Wrench

SERIES 152/302 FULL BORE

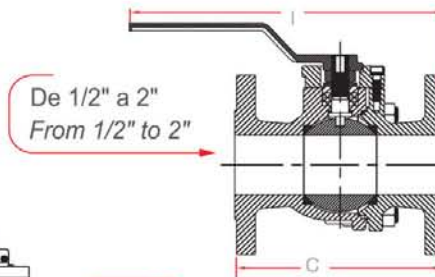
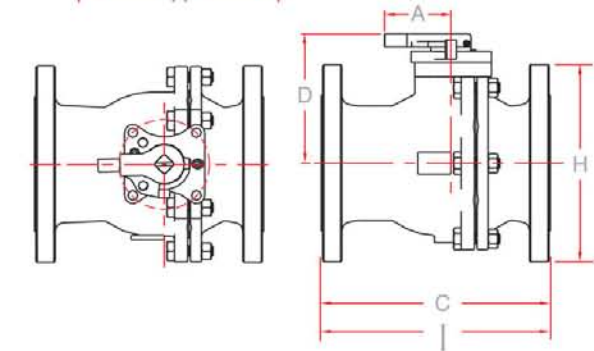
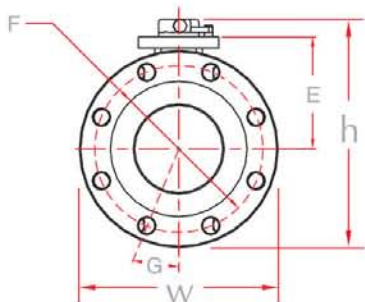
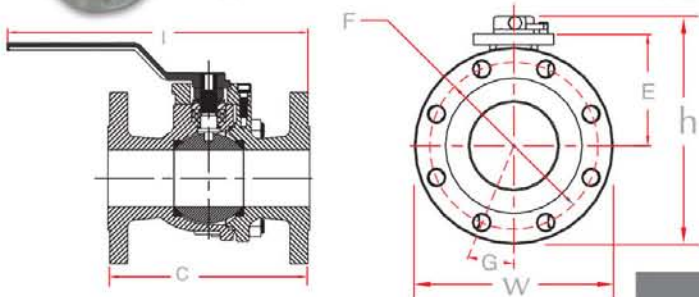

ISO 5211	
2	F07
3	F10
4	F10
6	F12/F14

ISO 5211	
1/2	F03/F05
3/4	F03/F05
1	F05
1 1/2	F07
2	F07
3	F10
4	F10
6	F12/F14
8	F12/F14

Serie 152 • Series 152

Medida / Size	A	C	D	E	F	G	H	Paso Bore	Peso / Weight		Largo / Length	Altura / Height	Ancho / Width
									kg	lb			
1/2	4.25	4.25	2.89	1.80	2.38	45°	3.50	.500	1.630	3.59	6.41	4.64	3.50
3/4	4.25	4.62	3.08	2.00	2.75	45°	3.88	.750	2.200	4.80	6.56	5.02	3.88
1	5.75	5.00	3.25	2.25	3.12	45°	4.25	1.000	3.000	6.60	8.32	5.38	4.25
1 1/2	7.00	6.50	4.50	3.04	3.88	45°	5.00	1.500	6.910	15.23	10.41	7.00	5.00
2	7.00	7.00	4.75	3.30	4.75	45°	6.00	2.000	8.720	19.22	10.66	7.75	6.00
3	3.00	8.00	5.38	4.47	6.00	45°	7.50	3.000	19.200	42.33	8.00	9.13	7.50
4	3.00	9.00	6.02	5.10	7.50	22.5°	9.00	4.000	29.800	65.60	9.00	10.52	9.00
6	4.50	15.50	8.66	7.40	9.50	22.5°	11.00	6.000	62.200	137.15	15.50	14.16	11.00
8	4.50	18.00	10.00	8.85	11.75	22.5°	13.50	8.000	94.000	207.20	18.00	16.75	13.50

Nota: Dimensiones en pulgadas • Note: All dimensions in inch

Serie 302 • Series 302

Medida / Size	A	C	D	E	F	G	H	Paso Bore	Peso / Weight		Largo / Length	Altura / Height	Ancho / Width
									kg	lb			
2	7.00	8.50	4.75	3.30	5.00	22.5°	6.50	2.00	11.38	25.09	10.74	8.00	6.50
3	3.00	11.12	5.38	4.65	6.62	22.5°	8.25	3.00	28.80	63.40	12.00	9.50	8.25
4	3.00	12.00	6.00	5.10	7.88	22.5°	10.00	4.00	40.60	89.50	12.00	11.02	10.00
6	4.50	15.88	8.66	7.53	10.62	15°	12.50	6.00	84.80	186.98	15.88	14.91	12.50

Nota: Dimensiones en pulgadas • Note: All dimensions in inch

SERIES 600 FLANGED

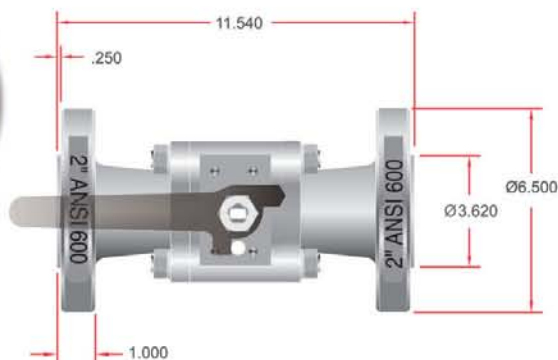

Válvula de bola, diseño de 3 piezas clase 600, construcción robusta en material de acero al carbón y acero inoxidable, conexión bridada, RF, paso completo, Cuerpo con arreglo para fácil automatización.

Ball valve, three-piece design, flanged, full bore, class ANSI 600, strong construction in carbon or stainless steel. Fixed for easy automation.

OPCIONES:

Libre de grasa, Dispositivo para candado, de acuerdo a API 6D y Control de Inyección. Adaptador con diseño ISO 5211

OPTIONS:

Oil free, Locking device, in accordance with API 6D and Injection Control. Bracket with ISO 5211 design.

Dimensiones • Dimensions
Serie 600 • Series 600

Asiento Seat	Sello del cuerpo Body seal	Sello del vástago Stem seal
R -PTFE	R -PTFE	R -TFE

Serie 600 Paso Completo • Series 600 Full Bore

Válvula Valve	ANSI B16.34 Clase • Class	Acero al Carbón • Carbon Steel		Acero Inoxidable • Stainless Steel	
		Presión de Trabajo Working Pressure	Presión Max. de Prueba Max. Test Pressure	Presión de Trabajo Working Pressure	Presión Max. de Prueba Max. Test Pressure
Serie 600 Bridada Paso Completo Series 600 Flanged Full Bore	600	1480 psi	2225 psi	1440 psi	2175 psi

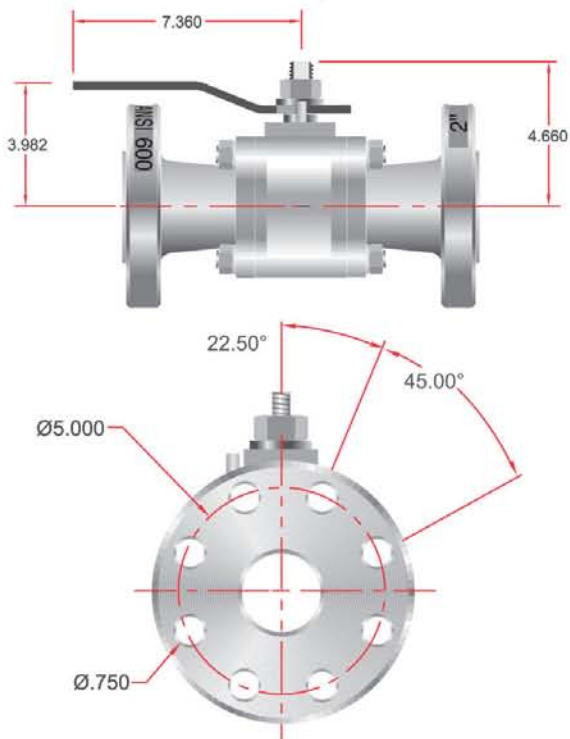

Nota: Solo disponible en 2"
Note: Available only in 2"

Lista de partes
List of components

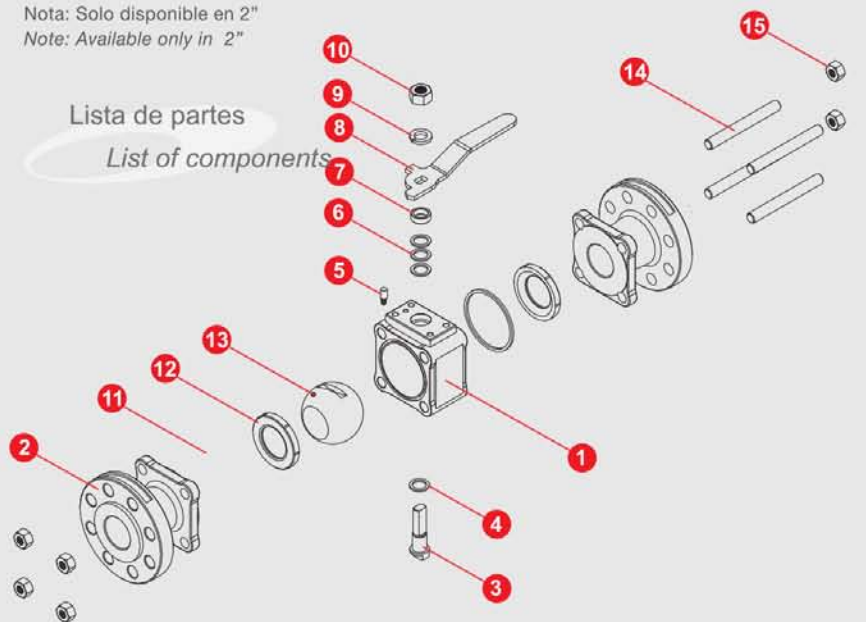

- 1 Cuerpo • Body
- 2 Tapa bridada • Flange cover
- 3 Vástago • Stem
- 4 Roldana inferior de vástago • Thrust bearing
- 5 Tope • Stop ping
- 6 Roldana de vástago • Stem seal
- 7 Separador • Stem Seal Follower
- 8 Maneral • Handle
- 9 Seguro de vástago • Lock washer
- 10 Tuerca del Vástago • Stem nut
- 11 Sello del Cuerpo • Body Seal
- 12 Asiento • Seat
- 13 Bola • Ball
- 14 Body • Stud
- 15 Tuerca • Nut

SERIES 151 REDUCE BORE



Válvula de bola Clase 150, paso reducido, diseño corto (short pattern) para instalar entre bridas, cuerpo de una pieza con tapón roscado en medidas de 3", 4" y 6". Construcción en materiales de acero al carbon y acero inoxidable, sellos para ciclos frecuentes. Partes compatibles con serie 150, plato ISO 5211, ideal en situaciones de espacio reducido. Diseño de manera corto para operar la Válvula con palanca.

Ball valve, reduced bore, short-pattern design for installing flanges. One-piece body with plug in sizes 3", 4" and 6" Material of construction in carbon and stainless steel. seals for frequent cycles. Compatible parts with series 150, ISO Plate 5211, ideal for installation in areas with reduced space. Short handle for operating the valve with a lever.

OPCIONES:

Diversos materiales de sellos y asientos, vástago antiestático, libre de grasa, dispositivo para candado. Automatización con actuador eléctrico ó neumático.

OPTIONS:

Diversity in materials for seats and seals, antistatic device, oil free. Locking device. The valve can be automated with an electric or pneumatic actuator.

Serie 151 Materiales de sellos y asientos
Series 151 Seal and seat materials

Asiento Seat	Sello del cuerpo Body seal	Sello del vástago Stem seal
B BUNA	B BUNA	R R-PTFE
T PTFE	*T PTFE	*R R-PTFE
R R-PTFE	T PTFE	R R-PTFE / M MULTIFIL
Y DELRIN	B BUNA	R R-PTFE
M MULTIFIL	M MULTIFIL	M MULTIFIL
U UHMWPE	V VITON	R R-PTFE
P PEEK	M MULTIFIL/GRAPHOIL	M MULTIFIL
I PTFE + INOX.	M MULTIFIL	M MULTIFIL

* Materiales estandar / Standard materials

Válvula Valve	ANSI B16.34 Clase + Class	Acero al Carbón • Carbon Steel		Acero al Inoxidable • Stainless Steel	
		Presión de Trabajo Working Pressure	Presión Max.de Prueba Max. Test Pressure	Presión de Trabajo Working Pressure	Presión Max.de Prueba Max. Test Pressure
Serie 151 • Series 151	150	285 psi	450 psi	275 psi	425 psi



Lista de partes
List of components

- 1 Cuerpo • Body
- 2 Asiento • Seat
- 3 Bola • Ball
- 4 Sello de cuerpo • Body seal
- 5 Tapón • Plug
- 6 Vástago • Stem
- 7 Roldana inferior • Thrust bearing
- 8 Prisionero • Retaining screw
- 9 Sello de vástago • Stem seal
- 10 Separador • Stem follower
- 11 Roldana cóncava • Belleville washer
- 12 Placa tope • Stop plate
- 13 Tuerca autotrabante • Retaining nut
- 14 Prisionero de maneral • Retaining screw
- 15 Maneral • Handle
- 16 Tornillo tope • Stop screw
- 17 Palanca • Wrench

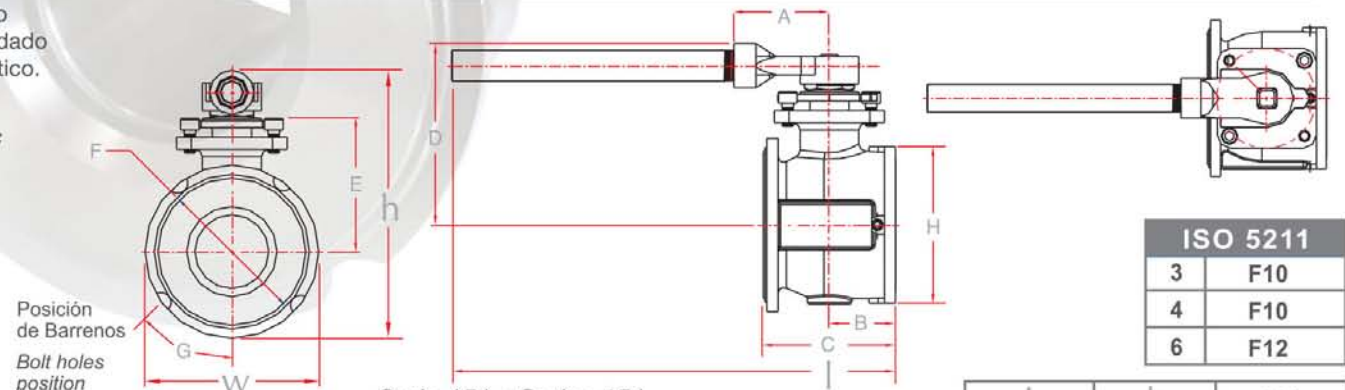

ISO 5211	
3	F10
4	F10
6	F12

Medida / Size	A	B	C	D	E	F	G	H	Paso Bore	Peso / Weight		Largo / Length	Altura / Height	Ancho / Width
										kg	lb			
3	3 1/4	2.26	4.50	6.16	4.43	5.26	45°	5.35	2.50	10.41	22.95	27.21	8.88	5.88
4	3 1/4	2.91	5.81	6.42	4.48	6.19	22.5°	7.62	3.25	16.00	35.20	25.50	10.23	7.50
6	4 11/32	3.69	7.38	9.00	6.19	8.60	22.5°	9.62	4.37	32.00	70.50	34.18	13.81	9.88

Nota: Dimensiones en pulgadas • Note: All dimensions in inch



Válvula de bola para 3000 WOG, paso reducido, conexiones NPT, BSPP, BSPT, SW y BW, construcción robusta en materiales de acero al carbón y acero inoxidable. Cuerpo de 3 pzas en medidas de 1/2" a 2", bola y vástago en 17.4 PH, tornillos B7, sellos de uso rudo para servicio de alta presión. Cuerpo con base ISO 5211.
(Excepto Válvulas de 2")

*Ball valve for 3000 WOG, reduced bore, connections NPT, BSPP, BSPT, SW and BW, three-piece design, strong construction in carbon and stainless steel. The valve is available in sizes from 1/2" to 2". Ball and stem 17.4 PH, screws B7, seals for rough use resisting high pressures. ISO Plate 5211.
(Except 2"Valves)*

OPCIONES:

- Paso completo
- Dispositivo para candado
- Extensión del vástago
- Libre de grasa
- Automatización con actuador eléctrico ó neumático.

OPTIONS:

- Full bore
- Locking device
- Stem extensions
- Oil Free
- The Valve can be automated with an electric or pneumatic actuator.

ASTM A216 WCB - ASTM A351 CF8M	
Válvula Valve	Presión Max. de operación Max. work pressure
Opción • Option H600	3000 WOG

Asiento Seat	Sello del cuerpo Body Seal	Sello del vástago Stem Seal
*Y DELRIN P PEEK	*V VITON V VITON	*Y DELRIN / MT MULTIFIL MT MULTIFIL

*Materiales Estandar / Standard Materials

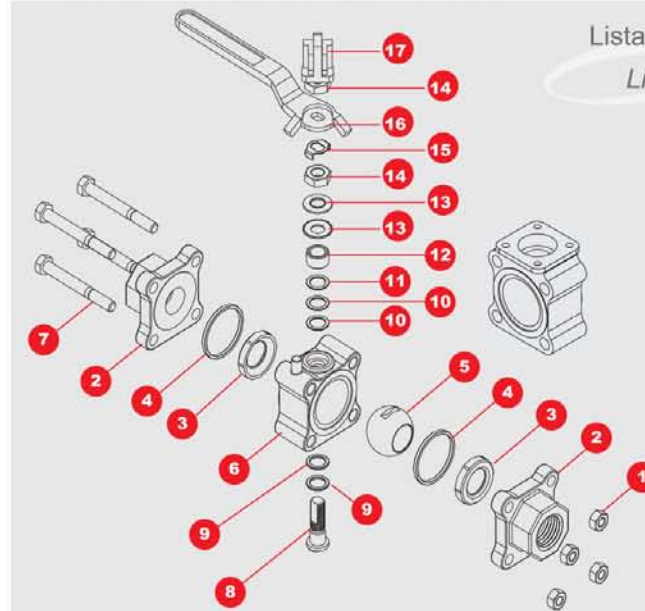

Lista de partes

List of components

- 1 Tuerca del cuerpo • Body nut
- 2 Tapa • Pipe end
- 3 Asiento • Seat
- 4 Sello de cuerpo • Body seal
- 5 Bola • Ball
- 6 Cuerpo • Body
- 7 Tornillo del cuerpo • Body bolt
- 8 Vástago • Stem
- 9 Roldana inferior de vástago • Thrust bearing
- 10 Roldana superior de vástago • Stem seal
- 11 Roldana de apoyo • Seal protector
- 12 Separador • Follower
- 13 Roldana cóncava • Belleville washer
- 14 Tuerca de vástago • Stem nut
- 15 Seguro para tuerca de vástago • Nut lock
- 16 Maneral • Handle
- 17 Dispositivo para candado (opcional)
• Locking device (optional)

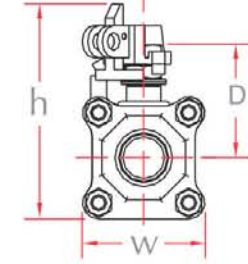
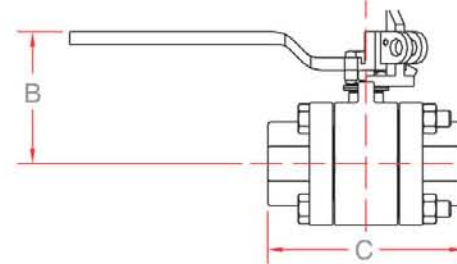
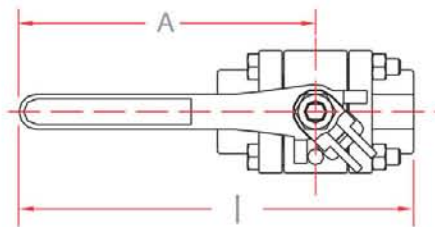

Serie H600 • Series H600

Medida / Size	A	B	C	D	Paso Bore	Peso / Weight		Largo / Length	Altura / Height	Ancho / Width
						kg	lb			
1/2	4.31	1.74	2.61	1.50	.440	0.59	1.30	5.56	2.45	1.75
3/4	4.31	1.83	2.83	1.59	.560	0.75	1.60	5.67	2.67	2.00
1	5.75	2.38	3.72	2.15	.810	1.46	3.20	7.66	3.40	2.38
1 1/4	5.75	2.57	4.22	2.35	1.00	2.01	4.40	7.86	3.71	2.63
1 1/2	7.00	2.98	4.56	2.87	1.25	3.33	7.30	9.28	4.62	3.19
2	7.00	3.17	5.01	3.06	1.50	4.29	9.40	9.51	5.00	3.57

Nota: Dimensiones en pulgadas • Note: All dimensions in inch

SERIES 6000 CLASS 2500 FULL BORE

2500#



Válvula de bola de construcción robusta de uso rudo para alta presión. Cuerpo de 2 piezas fabricadas de barra en acero al carbón o acero inoxidable con conexiones NPT, BSPP, BSPT, SW y BW. Paso completo en medidas de 1/2" a 2".

Presión máxima de operación de 6000 psi. Bola y vástago en 17-4PH.

Nota: Para conexiones SW y BW se recomienda solicitar una extensión de tubo de 4" de largo para evitar daños en asientos y sellos causados por las altas temperaturas durante la instalación

Válvula Valve	ANSI B16.34 Clase • Class	Acero al Carbón • Carbon Steel		Acero al Inox. • Stainless Steel	
		Presión de Trabajo Working Pressure	Presión max. de Prueba Max. test Pressure	Presión de Trabajo Working Pressure	Presión max. de Prueba Max. test Pressure
Serie 6000 • Series 6000	2500	6170 psi	9255 psi	6000 psi	9000 psi

Ball valve, full bore, 2-piece design, strong construction, made from steel bar in carbon and stainless steel.

The valve is available in sizes from 1/2" to 2". Ball and stem 17.4PH, seals for rough use resisting high pressures, maximum work pressure is 6000 psi.

Connections NPT, BSPP, BSPT, SW and BW.

Note: the best way to install SW or BW connection is by welding an extension at the end sides of the valve with a length of 4" avoiding damages to the seats and seals, caused by heat during the installation.

- 1 Cuerpo • Body
- 2 Aro del asiento • Seat o-ring
- 3 Asiento • Seat
- 4 Bola • Ball
- 5 O-ring del tapón • Plug end internal o-ring
- 6 O-ring del tapón • Plug end external o-ring
- 7 Tapón • Plug end
- 8 Vástago • Stem
- 9 Roldana de apoyo • Washer
- 10 Sello de vástago • Stem seal
- 11 Tornillo tope • Stop screw
- 12 Separador • Stem follower
- 13 Roldana cóncava • Belleville washer
- 14 Tuerca de vástago • Stem nut
- 15 Seguro para tuerca de vástago • Lock nut
- 16 Maneral • Handle
- 17 Seguro de maneral • Handle lock

Lista de partes
List of components

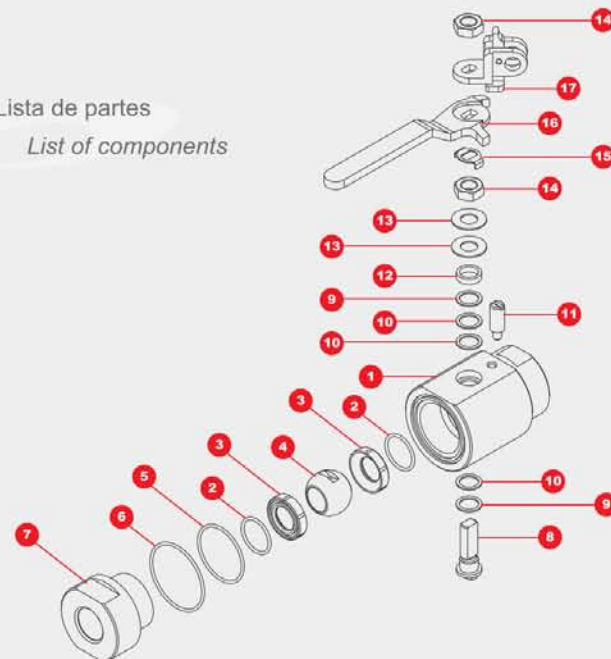

2500#



Opciones:

Dispositivo para candado Automatización con actuador eléctrico ó neumático con montaje especial.

Cuerpo y tapón de acero forjado.

Options:

Locking device, the valve can be automated with an electric or pneumatic actuator by means of special mounting.

Body and end Forged Steel.

Serie 6000 • Series 6000

Medida / Size	A	B	C	D	Paso Bore	Peso / Weight	
						kg	lb
1/2	4.25	1.81	3.26	1.67	.500	1.04	2.29
3/4	5.75	2.35	3.75	2.17	.750	1.75	3.86
1	5.75	2.62	4.44	2.38	1.000	2.56	5.64
1 1/2	7.13	3.57	5.12	3.07	1.500	8.49	18.72
2	7.34	4.44	5.50	4.62	2.000	13.59	29.96

Nota: Dimensiones en pulgadas • Note: All dimensions in inch

SERIES 6000 CLASS 2500 FULL BORE

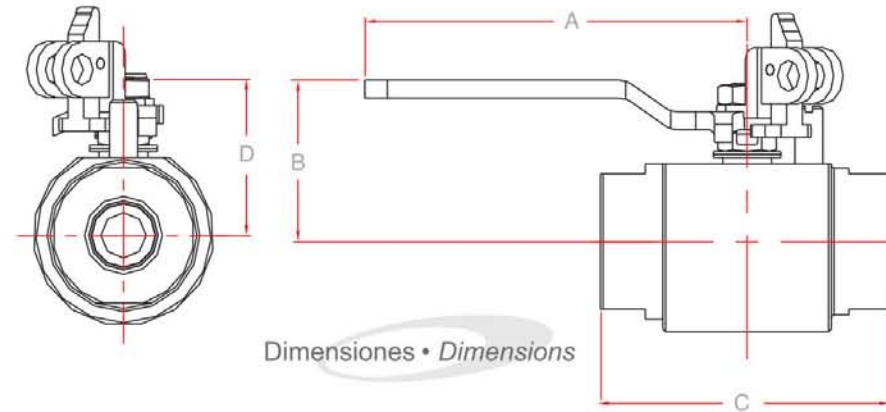

*Materiales estandar • Standard materials

Asiento Seat	Sello del cuerpo Body Seal	Sello del vástago Stem Seal
*Y DELRIN	*V VITON	*Y DELRIN / MT MULTIFIL
P PEEK	V VITON	Y DELRIN / MT MULTIFIL
D DEVLON	V VITON	Y DELRIN / MT MULTIFIL

SERIES 6000 CLASS 900 FULL BORE



Válvula de bola construcción robusta Clase 900. Cuerpo soldado a prueba de fuego, fabricada de barra en acero al carbón y acero inoxidable con conexiones NPT, BSPT, BSPP, y SW y BW. Paso completo en medidas de 1/2" a 2". Presión máxima de operación de 2250 psi. Bola y vástago en AISI 316.

Nota: Para conexiones SW y BW se recomienda solicitar una extensión de tubo de 4" de largo para evitar daños en asientos y sellos causados por las altas temperaturas durante la instalación.

Ball valve, strong construction as per ANSI 900#, welded body, Fire Safecertified. Made from bar stock in carbon and stainless steel. Connections available in NPT, BSPP, BSPT, SW and BW. Full port in sizes from 1/2" to 2". Ball and stem AISI 316, seals for rough use resisting high pressures, maximum work pressure is 2250 psi.

Note: the best way to install SW or BW connection is by welding an extensión at the end sides of the valve with a length of 4" avoiding damages to the seats and seals, caused by heat during the installation.

Válvula Valve	ANSI B16.34 Clase • Class	Acero al Carbón • Carbon Steel		Acero Inoxidable • Stainless Steel	
		Presión de Trabajo Working Pressure	Presión Max.de Prueba Max. Test Pressure	Presión de Trabajo Working Pressure	Presión Max.de Prueba Max. Test Pressure
Serie 6000 • Series 6000	900	2220 psi	3350 psi	2160	3250

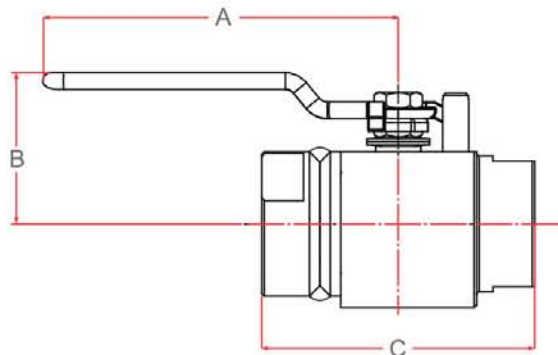
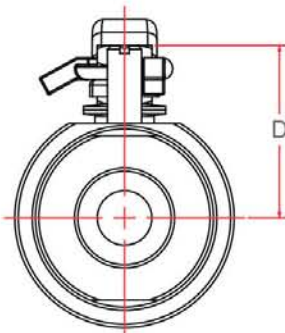

Lista de partes
List of components

- 1 Cuerpo • Body
- 2 Tapón • Plug end
- 3 Bola • Ball
- 4 Vástago • Stem
- 5 Asiento • Seat
- 6 Sello de Vástago • Stem seal
- 7 Rondana de Apoyo • Washer
- 8 Separador • Stem follower
- 9 Maneral • Handle
- 10 Tornillo tope • Stop screw
- 11 Roldana concava • Belleville washer
- 12 Seguro para tuerca de vástago • Lock nut
- 13 Tuerca de Vástago • Stem nut

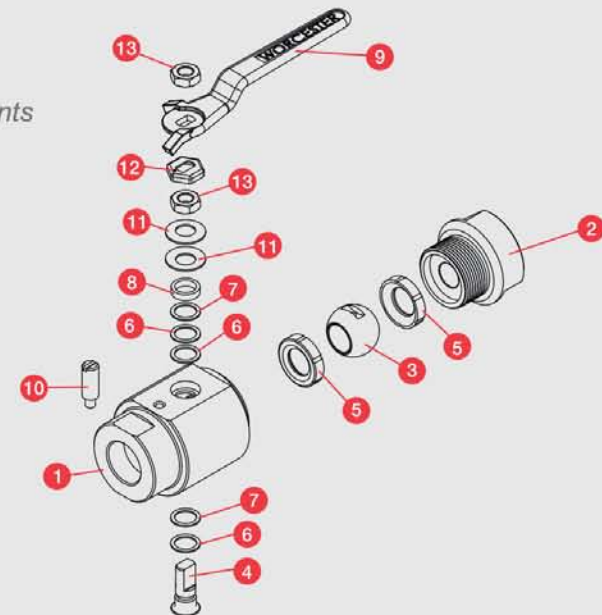

SERIES F-400 / F-600 FIRE SAFE

Válvula de bola diseñada para proteger la integridad de la línea de proceso en condiciones de fuego. Provista de sellos de Grafoil y un labio metálico que funciona como sello secundario y asiento de PTFE. Construcción robusta en materiales de acero al carbón y acero inoxidable, conexiones NPT, BSPP, BSPT, SW, BW. Disponible en medidas de 1/4" a 2" (Serie F-400) y de 1/2" a 2" (Serie F-600).
Cumple con el estándar API 607.

Ball valve specially designed for assuring the integrity of the process line under fire conditions, it is provided with Graphoil seals, a metal lip that acts as an emergency seal, and PTFE seats. Strong construction in carbon and stainless steel. End connections available in NPT, BSPP, BSPT, SW and BW. The valve is available in sizes from 1/4" to 2" (Series F-400) and from 1/2" to 2" (Series F-600). This model complies with API 607 standard, and CE Marking available.

OPCIONES:

- Diversos materiales de sellos y asientos.
- Paso Completo y Paso Reducido.
- Maneral Oval. Cuerpo ISO 5211. Automatización Especial

OPTIONS:

- Full and reduce bore. Diversity in materials for seats and seals
- Body ISO according to ISO 5211. Oval handle. Special automation.

* Material de asientos y sellos, serie 600
* Seat and seal materials series 600

* Estandar serie 400
* Standard series 400

F-400 • F-600		
Asiento Seat	Sello del Cuerpo Body Seal	Sello del vástago Stem Seal
*T PTFE		
R R-PTFE	*GRAFOIL	*R R-PTFE / GRAFOIL
MT MULTIFIL		

- 1 Tornillo del cuerpo reforzado • Strong body bolt
- 2 Tapa • Pipe end
- 3 Asiento • Seat
- 4 Sello de cuerpo • Body seal
- 5 Bola • Ball
- 6 Cuerpo • Body
- 7 Vástago • Stem
- 8 Roldana de vástago Inferior • Thrust bearing
- 9 Roldana de vástago Superior • Stem seal
- 10 Separador • Follower
- 11 Roldana cóncava • Belleville washer
- 12 Tuerca de Vástago • Stem nut
- 13 Seguro para tuerca de vástago • Lock nut
- 14 Maneral • Handle
- 15 Dispositivo para candado (opcional)
Locking device (optional)

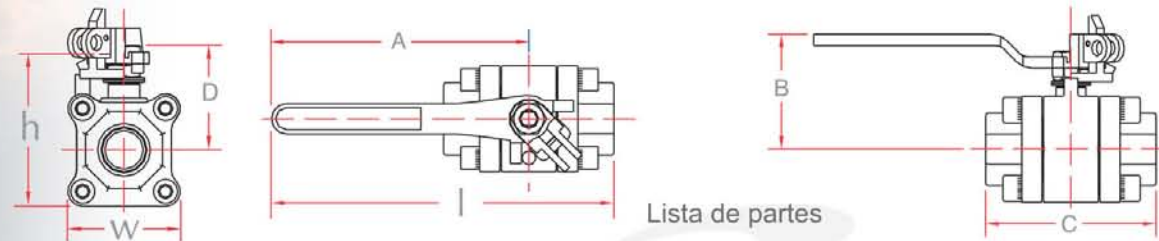
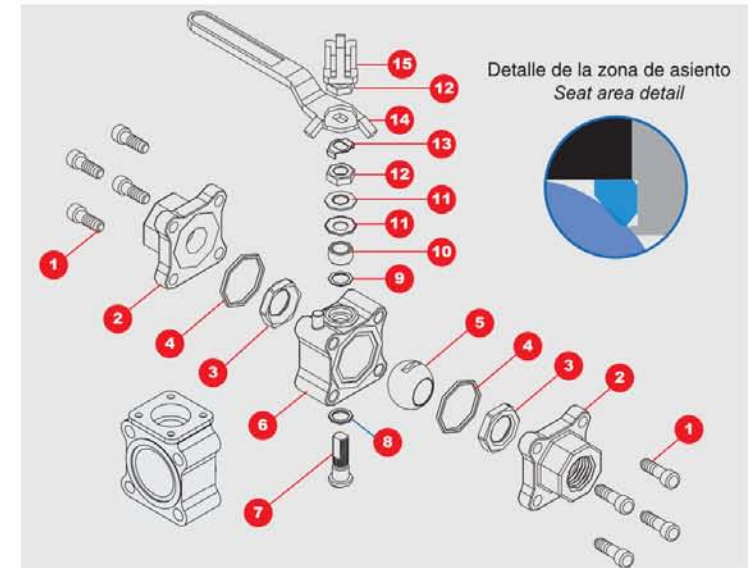

Lista de partes

List of components

Medida / Size	A	B	C	D	Paso Bore	Peso / Weight		Largo / Length	h	W
						kg	lb			
1/4 (paso total • full bore)	4.25	1.58	2.61	1.51	.438	0.6	1.40	5.56	2.45	1.75
3/8 (paso total • full bore)	4.25	1.58	2.61	1.51	.438	0.6	1.30	5.56	2.45	1.75
1/2 (paso reducido • reduced bore)	4.25	1.58	2.61	1.51	.438	0.5	1.30	5.56	2.45	1.75
3/4 (paso reducido • reduced bore) ■ 1/2 (paso total • full bore)	4.25	1.67	2.83	1.61	.563	0.7	1.60	5.67	2.67	2.00
1 (paso reducido • reduced bore) ■ 3/4 (paso total • full bore)	5.75	2.21	3.72	2.17	.813	1.4	3.20	7.66	3.40	2.38
1 1/4 (paso reducido • reduced bore) ■ 1 (paso total • full bore)	5.75	2.40	4.22	2.35	1.000	2.0	4.40	7.86	3.71	2.63
1 1/2 (paso reducido • reduced bore) ■ 1 1/4 (paso total • full bore)	7.00	3.02	4.56	2.89	1.250	3.3	7.30	9.28	4.62	3.19
2 (paso reducido • reduced bore) ■ 1 1/2 (paso total • full bore)	7.00	3.21	5.01	3.07	1.500	4.2	9.40	9.51	5.00	3.57

Nota: Dimensiones en pulgadas • Note: All dimensions in inch

SERIES F-152 / F-302 Fire SAFE



Válvula bridada de bola de 2 piezas, paso completo, diseñada para proteger la integridad de la línea de proceso en condiciones de fuego. Provista de sellos de Grafoil y de un labio metálico que funciona como sello secundario, y asientos de PTFE. Construcción robusta en materiales de acero al carbón y acero inoxidable. Cumple con el estándar API 607

Ball valve, 2-piece design, full bore, assuring the integrity of the process line under fire conditions. It is provided with Graphoil seals, a metal lip as an emergency seal, and PTFE seats. Strong construction in carbon and stainless steel. In accordance with API 607.

OPCIONES:

Diversos materiales de sellos y asientos
Automatización con actuador eléctrico o neumático.
Cumple con API 607, API 6D (en tamaños de 2" en adelante).

OPTIONS:

Diversity in materials for sets and seals
Automation with an electric or pneumatic actuator.
In accordance with API 607, API 6D (in sizes from 2" and larger).

*Materiales Estandar • Standard Materials

Serie • Series		F-152 • F-302
Asiento Seat	Sello del cuerpo Body Seal	Sello del vástago Stem Seal
* T PTFE		
R R-PTFE	* GRAFOIL	* R R-PTFE/GRAFOIL
MT MULTIFIL		

Material de asiento y sello • Seat and seal material

Válvula Valve	ANSI B16.34 Clase • Class	Acero al Carbón • Carbon Steel		Acero Inoxidable • Stainless Steel	
		Presión de trabajo Working pressure	Presión Máx. de prueba Max. Test pressure	Presión de trabajo Working pressure	Presión Máx. de prueba Max. Test pressure
Serie F-152 • Series F-152	150	285 psi	450 psi	275 psi	425 psi
Serie F-302 • Series F-302	300	740 psi	1125 psi	720 psi	1100 psi

Lista de partes
List of components

- 1 Serie F-152 • Series F-152 body
- 1a Serie F-302 • Series F-302 body
- 2 Serie F-152 • Series F-152 cover
- 2a Serie F-302 • Series F-302 cover
- 3 Bola • Ball
- 4 Asiento • Seat
- 5 Sello de cuerpo • Body seal
- 6 Tornillos del cuerpo • Body bolts
- 7 Tuercas del cuerpo • Body nuts
- 8 Vástago • Stem
- 9 Sello de vástago • Stem seal
- 10 Seguidor inferior • Thrust bearing
- 11 Empaque tipo chevron • Chevron type seal
- 12 Seguidor superior • Follower
- 13 Roldana cóncava • Belleville washer
- 14 Tuerca autotrabante • Stem nut
- 15 Base ISO (opcional) • ISO base (optional)
- 16 Dispositivo para candado • Locking device
- 17 Tornillos de la base • Base screw
- 18 Maneral • Handle
- 19 Prisonero • Set screw
- 20 Palanca • Wrench

Serie 152 • Series 152

Medida / Size	A	C	D	E	F	G	H	Paso Bore	Peso / Weight		Largo / Length	Altura / Height	Ancho / Width
									kg	lb			
1/2	4.25	4.25	2.89	1.80	2.38	45°	3.50	.500	1.630	3.59	6.41	4.64	3.50
3/4	4.25	4.62	3.08	2.00	2.75	45°	3.88	.750	2.200	4.80	6.56	5.02	3.88
1	5.75	5.00	3.25	2.25	3.12	45°	4.25	1.000	3.000	6.60	8.32	5.38	4.25
1 1/2	7.00	6.50	4.50	3.04	3.88	45°	5.00	1.500	6.910	15.23	10.41	7.00	5.00
2	7.00	7.00	4.75	3.30	4.75	45°	6.00	2.000	8.720	19.22	10.66	7.75	6.00
3	3.00	8.00	5.38	4.47	6.00	45°	7.50	3.000	19.200	42.33	8.00	9.13	7.50
4	3.00	9.00	6.02	5.10	7.50	22.5°	9.00	4.000	29.800	65.60	9.00	10.52	9.00
6	4.50	15.50	8.66	7.40	9.50	22.5°	11.00	6.000	62.200	137.15	15.50	14.16	11.00
8	4.50	18.00	10.00	8.85	11.75	22.5°	13.50	8.000	94.000	207.20	18.00	16.75	13.50

Nota: Dimensiones en pulgadas • Note: All dimensions in inch

SERIES F-152 / F-302 Fire SAFE

ISO 5211	
1/2	F03/F05
3/4	F03/F05
1	F05
1 1/2	F07
2	F07
3	F10
4	F10
6	F12/F14
8	F12/F14

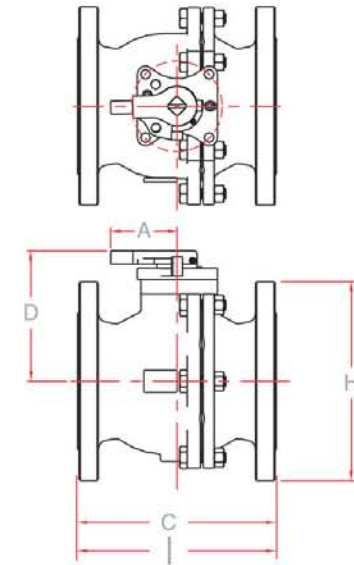

Dimensiones • Dimensions

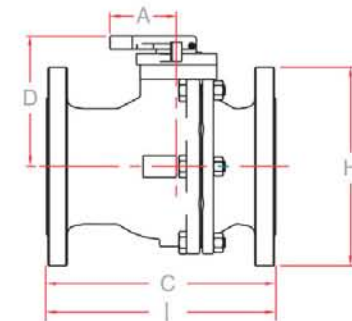

ISO 5211	
2	F07
3	F10
4	F10
6	F12/F14

Serie F-302 A Prueba de Fuego
Series F-302 Fire Safe

Serie 302 • Series 302

Medida / Size	A	C	D	E	F	G	H	Paso Bore	Peso / Weight		Largo / Length	Altura / Height	Ancho / Width
									kg	lb			
2	7.00	8.50	4.75	3.30	5.00	22.5°	6.50	2.00	11.38	25.09	10.74	8.00	6.50
3	3.00	11.12	5.38	4.65	6.62	22.5°	8.25	3.00	28.80	63.40	12.00	9.50	8.25
4	3.00	12.00	6.00	5.10	7.88	22.5°	10.00	4.00	40.60	89.50	12.00	11.02	10.00
6	4.50	15.88	8.66	7.53	10.62	15°	12.50	6.00	84.80	186.98	15.88	14.91	12.50

Nota: Dimensiones en pulgadas • Note: All dimensions in inch

SERIES 400/600 3 WAYS VALVE



Válvula de bola con tercer vía inferior o lateral, clase 400 y clases 600, diseño de 3 piezas en materiales de latón, acero al carbón y acero inoxidable. Disponible en medidas de 1/2" a 2" en paso reducido y de 1/4" a 1 1/2" en paso completo, conexiones NPT, BSPP, BSPT, SW, BW o Clamp.

Nota:
Para conexión Clamp disponible solo en clase 400

Three-way ball valve, Class 400 and 600, 3-piece design, in brass, carbon, and stainless steel. Available in sizes from 1/2" to 2" in reduced bore and from 1/4" to 1 1/2" in full bore. Connections NPT, BSPP, BSPT, SW, BW, and Clamp.

Note:
Clamp connection only available in Class 400

Nota: La conexión estándar de la 3er vía es roscada
Note: The standard three-way connection is threaded

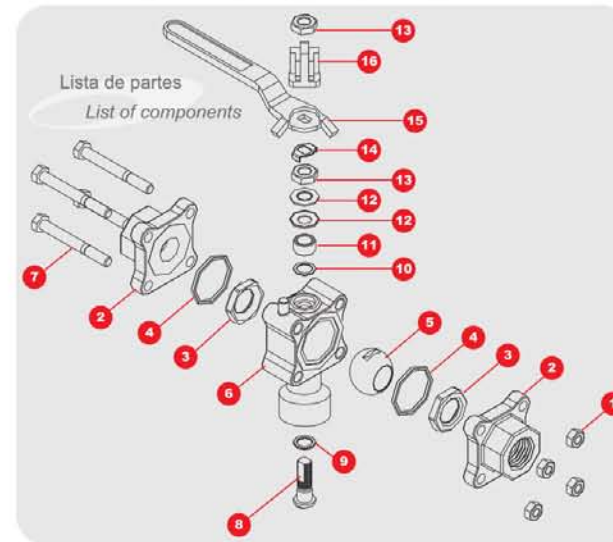

- 1 Tuerca del cuerpo • Body nut
- 2 Tapa • Pipe end
- 3 Asiento • Seat
- 4 Sello de cuerpo • Body seal
- 5 Bola • Ball
- 6 Cuerpo • Body
- 7 Tornillo del cuerpo • Body bolt
- 8 Vástago • Stem
- 9 Roldana de Vástago inf. • Thrust bearing
- 10 Roldana de Vástago sup. • Stem seal
- 11 Separador. • Follower
- 12 Roldana cóncava. • Belleville washer
- 13 Tuerca de vástago. • Stem nut
- 14 Seguro para Tuerca de vástago • Lock nut
- 15 Maneral. • Handle
- 16 Dispositivo para candado (opcional) • Locking device (optional)

OPERACIONES de 0° a 180° con tres opciones de configuración: Porting 1, Porting 2 y Porting 3.

TRES VIAS. Con asientos integrales que permiten la entrada del flujo por cualquier puerto.

DIVERTER. Asientos y sellos para desviar el flujo del puerto inferior hacia los lados.

PORTING 1. Operación 0° a 90°, sin posición de cerrado.

PORTING 2. Operación 0° a 180°, con posición de cerrado a 90°.

PORTING 3. Operación 0° a 180°, con posición de mezcla a 90°.

OPERATIONS from 0° to 180° with three configuration options: Porting 1, Porting 2 and Porting 3.

3 WAYS. With integrated seats which allow the fluid feed through any entrance.

DIVERTER. Individual seats and seals for deflecting the fluid from the inferior port to both sides.

PORTING 1. Operation from 0° to 90° without close position.

PORTING 2. Operation from 0° to 180° with close position at 90°.

PORTING 3. Operation from 0° to 180° with mixing position at 90°.

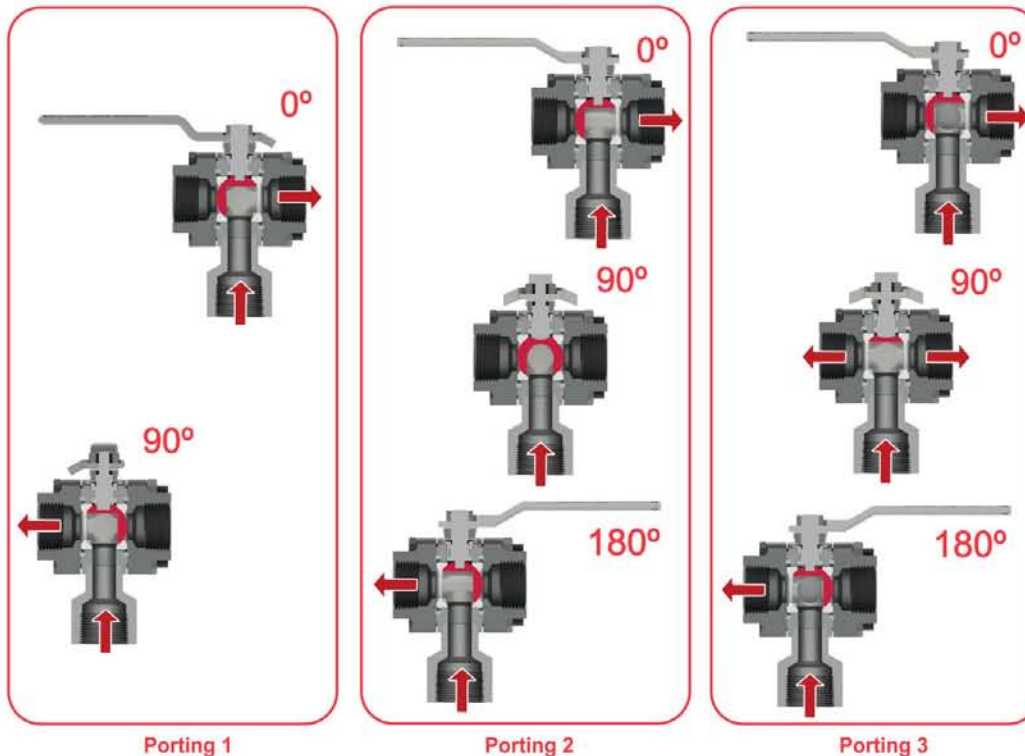

Serie 400 Materiales de sellos y asientos
Series 400 Seal and seat material

Asiento Seat	Sello del cuerpo Body seal	Sello del vástago Stem seal
B BUNA	B - BUNA	
* T PTFE	* T - PTFE	* R R-PTFE
R R-PTFE	M - MULTIFIL	
M MULTIFIL	V - VITON	
I PTFE + INOX.	G - GRAFOIL	M MULTIFIL
Y DELRIN		
U UHMWPE		
P PEEK		

* Materiales estandar / Standard materials

OPCIONES

- 1 Diversos materiales de asientos y sellos
- 2 Asientos cavity filled
- 3 Maneral oval
- 4 Libre de grasa
- 5 Vástago antiestático
- 6 Dispositivo para candado
- 7 Cuerpo ISO 5211
- 8 Extensión de Vástago
- 9 Automatización eléctrica ó neumática (Porting 1, 2 y 3)
- 10 3er. vía en puerto lateral
- 11 Diversas conexiones para la 3ra vía
- 12 BSPP, BSPT, SW, BW, Clamp
- 13 Paso completo
- 14 Criogénica

OPTIONS

- 1 Diversity in material for seats and seals
- 2 Cavity filled seat
- 3 Oval handle
- 4 Oil free
- 5 Antistatic device
- 6 Locking device
- 7 Body ISO 5211
- 8 Stem extension
- 9 Pneumatic or electric automation (Porting 1, 2 & 3)
- 10 3rd way at lateral port
- 11 Various connections for the 3rd way
- 12 BSPP, BSPT, SW, BW, Clamp
- 13 Full bore
- 14 Cryogenic

Puerto Lateral *Lateral Bore*

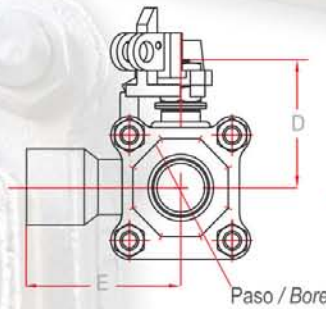

Puerto Inferior *Inferior Bore*

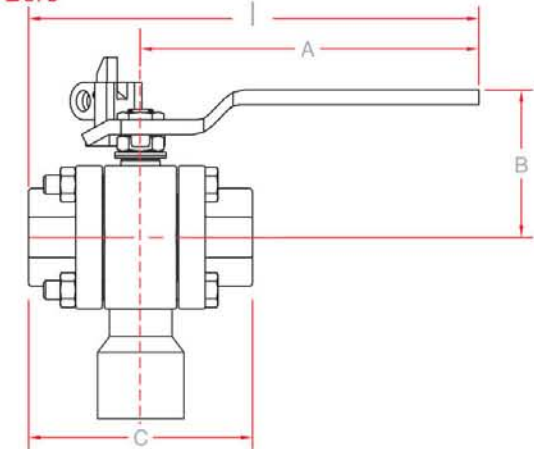
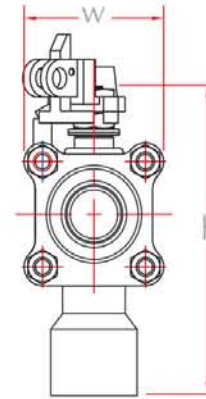

Serie 400 3 vías (paso reducido) • Series 400 3 ways (reduced bore)

Medida / Size	A	B	C	D	E	Paso Bore	Peso / Weight		Largo /Length	Altura /Height	Ancho /Width
							kg.	lb			
1/2	4.32	1.61	2.65	1.51	2.31	.438	0.640	1.410	5.63	3.81	1.75
3/4	4.32	1.61	2.83	1.61	2.48	.563	0.800	1.760	5.67	4.09	2.00
1	5.77	2.21	3.72	2.17	3.06	.813	1.600	3.530	7.66	5.23	2.38
1 1/4	5.77	2.52	4.22	2.34	3.57	1.000	2.380	5.240	7.89	5.91	2.63
1 1/2	7.04	3.02	4.56	2.89	3.56	1.250	3.800	8.380	9.28	6.45	3.19
2	7.04	3.13	5.03	3.09	4.13	1.500	4.790	10.560	9.58	7.21	3.56

Serie 400 3 vías (paso completo) • Series 400 3 ways (full bore)

Medida / Size	A	B	C	D	E	Paso Bore	Peso / Weight		Largo /Length	Altura /Height	Ancho /Width
							kg.	lb			
1/4	4.32	1.61	2.65	1.51	2.31	0.438	0.64	1.410	5.63	3.81	1.75
3/8	4.32	1.61	2.65	1.51	2.31	0.438	0.64	1.410	5.63	3.81	1.75
1/2	4.32	1.61	2.83	1.61	2.48	0.563	0.80	1.760	5.67	4.09	2.00
3/4	5.77	2.21	3.72	2.17	3.06	0.813	1.60	3.530	7.66	5.23	2.38
1	5.77	2.52	4.22	2.34	3.57	1.000	2.38	5.240	7.89	5.91	2.63
1 1/4	7.04	3.02	4.56	2.89	3.56	1.250	3.80	8.380	9.28	6.45	3.19
1 1/2	7.04	3.13	5.03	3.09	4.13	1.500	4.79	10.560	9.58	7.21	3.56

Nota: Dimensiones en pulgadas • Note: All dimensions in inch

SERIES 15 3 WAYS VALVE



Lista de partes
List of components

- 1 Tapón • Plug
- 2 O-ring de cuerpo • Body o-ring
- 3 Sello de cuerpo • Body seal
- 4 Asiento • Seat
- 5 Bola • Ball
- 6 Vástago • Stem
- 7 O-ring de vástago • Stem o-ring
- 8 Sello de vástago • Stem seal
- 9 Base ISO (opcional) • ISO base (optional)
- 10 Tornillo base ISO • ISO base screw
- 11 Seguidor inferior • Thrust bearing
- 12 Empaque tipo chevron • Chevron type seal
- 13 Seguidor superior • Follower
- 14 Roldana cóncava • Belleville washer
- 15 Tuerca de vástago • Stem nut
- 16 Maneral • Handle
- 17 Tornillo del maneral • Handle screw
- 18 Seguro de maneral • Lock handle
- 19 Extensión de maneral • Handle extension
- 20 Cuerpo • Body

Válvula de bola con tercer vía inferior bridada clase 150. Cuerpo en construcción ligera, de 1 pza con tapón roscado en materiales de acero al carbón con interiores de acero inoxidable. Disponible en medidas de 1" a 6", paso reducido. Operación con base a **Porting 1**, **Porting 2** (con posición de cerrado) y **Porting 3** (con posición de mezclado) 3er vía bridada.

Ball valve with 3rd inferior way flanged, Class 150. Light construction, 1-piece design, with threaded plug in carbon and stainless steel. Available in sizes from 1" to 6" in reduce bore. Operation with **Porting 1**, **Porting 2** (closed position), and **Porting 3** (mixing position).

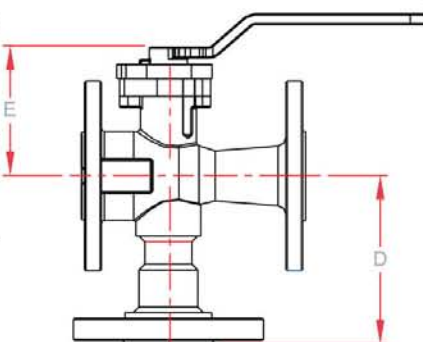
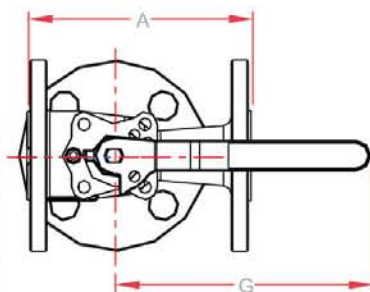

ISO 5211	
1/2	F03/F05
3/4	F03/F05
1	F05
1 1/2	F07
2	F07
3	F10
4	F10
6	F12/F14

Serie 15 3 vías • Series 15 3-way valve

Medida / Size	A	B	C	D	E	G
1	5.00	2.50	3.63	3.75	2.98	5.75
1 1/2	6.50	3.25	4.70	4.38	3.69	7.00
2	7.00	3.31	4.89	5.00	3.97	7.11
2 1/2	7.50	3.94	5.39	5.50	4.34	7.00
3	8.00	4.38	6.69	6.00	4.91	16.00
4	9.00	5.06	7.41	7.13	5.66	14.96
6	10.50	6.38	9.61	9.85	7.14	20.00

Nota: Dimensiones en pulgadas • Note: All dimensions in inch

Bridada S 15 3-vías • Flanged S15 3-way valve

Soldable o roscada S15 3-vías
Socket weld or threaded S15 3-way valve

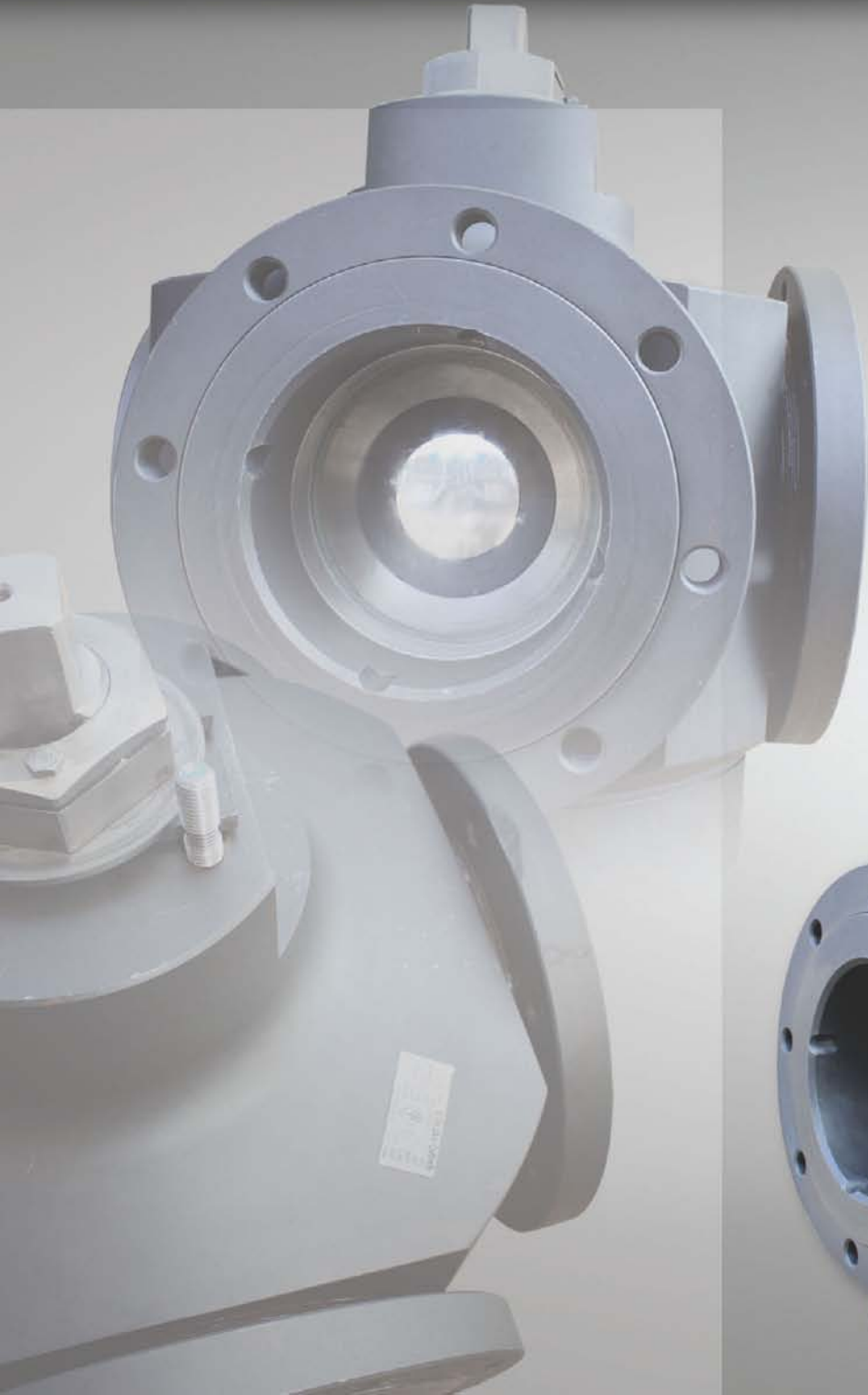

Multiport Valve
Full Bore
SERIES 18

MULTI-PORT VALVE SERIES 18

Válvula de bola flotante, Clase 150# y 300# en medidas de 2", 3" y 4" para alimentación y/o permutación a varias líneas de procesos. El diseño del cuerpo permite el uso de hasta 5 vías útiles en la Válvula. Vástago con sistema autoalineable, para compensar el uso, así como la contracción y expansión producida por cambios térmicos. El vástago esta provisto de dispositivo antiestático. Cuerpo con arreglo para fácil automatización.

Conexiones: brida tipo deslizable lo cual facilita el posicionado y montaje. Las bolas de permutación y/o alimentación son de tipo L, T, entrada inferior, y pasaje recto. Permitiendo una gran variedad de configuraciones.



Opciones:

Válvula multipuertos de fabricación especial. Válvula multipuertos de 6" Tipo Trunnion (de bola guiada) clase 150#, con entrada inferior. Automatización con actuador neumático.

Válvula Valve	ANSI B16.34 Clase • Class	Acero al Carbón • Carbon Steel		Acero Inoxidable • Stainless Steel	
		Presión de Trabajo Working Pressure	Presión Max.de Prueba Max. Test Pressure	Presión de Trabajo Working Pressure	Presión Max.de Prueba Max. Test Pressure
Serie 18 • Series 18	Serie 150	285	450 psi	275 psi	425 psi

Options:

Multiport ball valve of special production. Multiport ball valve of 6" type trunnion mounted ball valve class 150#, with bottom entry. Automation with pneumatic actuator.

Valve of floating ball, Class 150# and 300# in measures of 2", 3" and 4" for supply and/or permutation for several process lines. The design of the body allows the use of 5 useful ways in the valve. Stem with self-alignment system, to compensate the use, as well as the contraction and expansion produced by thermal changes. The stem is provided of antistatic device.

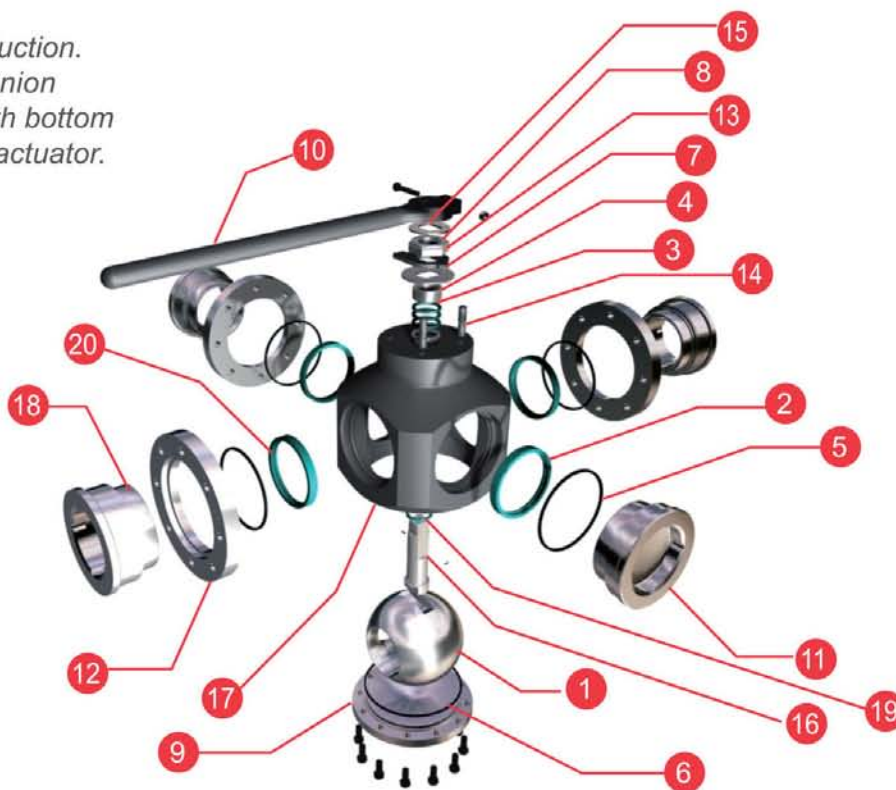

**LISTA DE PARTES
LIST OF COMPONENTS.**

1	BOLA	BALL
2	ASIENTO	SEAT
3	SELLO DEL VASTAGO	STEM SEAL
4	SEPARADOR	FOLLOWER
5	SELLO DEL TAPON	BODY-PLUG SEAL
6	SELLO DE LA TAPA	BODY-LID SEAL
7	INDICADOR DE POSICION	POSITION INDICATOR
8	TUERCA DE RETENCION.	RETENTION NUT.
9	TAPA.	PLUG END.
10	MANERAL	HANDLE.
11	TAPON CIEGO	BLIND PLUG
12	BRIDA DESLIZABLE	ADJUSTABLE FLANGE
13	PLACA TOPE	STOP PLATE
14	BIRLO	STUD
15	RONDANA SEGURO	LOCK WASHER
16	VASTAGO	STEM
17	CUERPO	BODY
18	TAPON	PLUG
19	ROLDANA DE APOYO	THRUST BEARING
20	O RING	O RING

MULTI-PORT VALVE SERIES 18



Series 18 Seal and seat materials

Asiento Seat	Sello del cuerpo Body seal	Sello del v. stago Stem seal
T PTFE	T PTFE	R R-PTFE
R R-PTFE	T PTFE	R R-PTFE / MT MULTIFIL
M MULTIFIL	M MULTIFIL	M MULTIFIL
I PTFE + INOX.	M MULTIFIL	M MULTIFIL

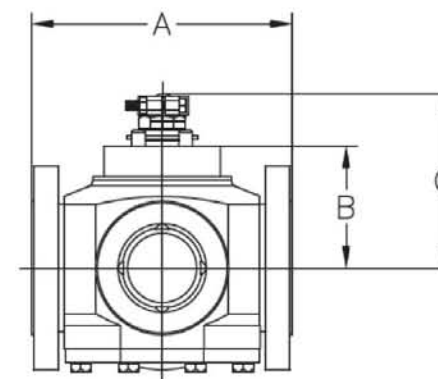
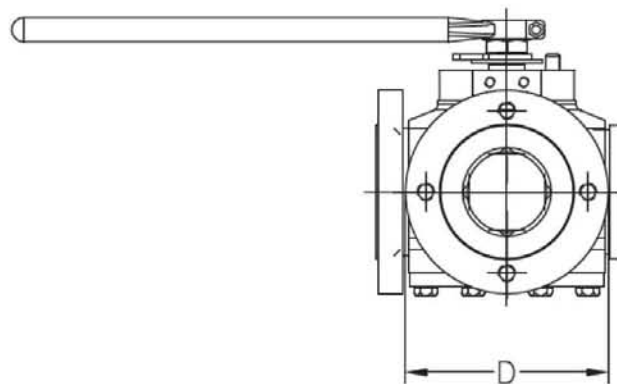

Serie 18 Paso completo • Series 18 Full bore

Medida / Size	A	B	C	D	Paso Bore	Peso / Weight	
						kg	lb
2"	7.99	3.08	6.50	6.00	2.00	23.00	50.7
3"	9.63	4.49	6.43	5.00	3.00	46.50	102.5
4"	12.00	6.20	8.89	9.00	4.00	89.00	196.2
6" (Trunnion)	15.88	8.38	11.29	11.00	5.90	190.0	418.8

Nota: dimensiones en pulgadas • Note: all dimensions in inches

MULTI-PORT VALVE SERIES 18

Opciones a 90° / Options 90°

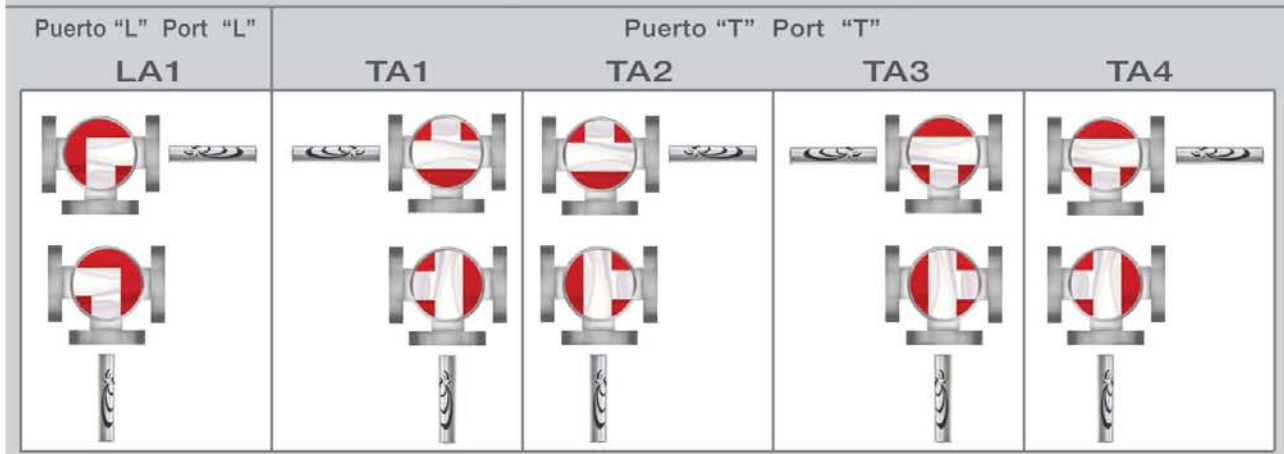

Opciones a 180° / Options 180°

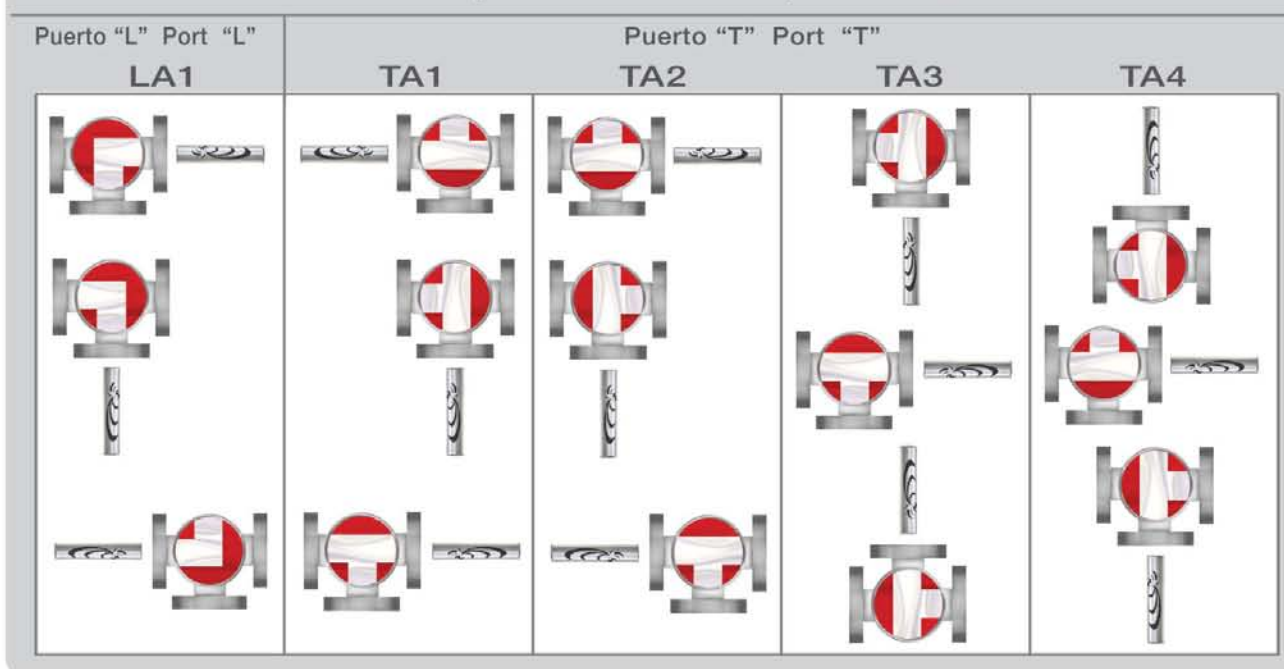

CONFIGURACIONES
CONFIGURATIONS

ENTRADA LATERAL
3 LADOS ABIERTOS - 1 LADO CIEGO

SIDE ENTRY
3 WAYS OPENED - 1 SIDE BLIND





CONFIGURACIONES
CONFIGURATIONS

ENTRADA LATERAL
4 LADOS ABIERTOS

SIDE ENTRY
4 WAYS OPENED

MULTI-PORT VALVE SERIES 18

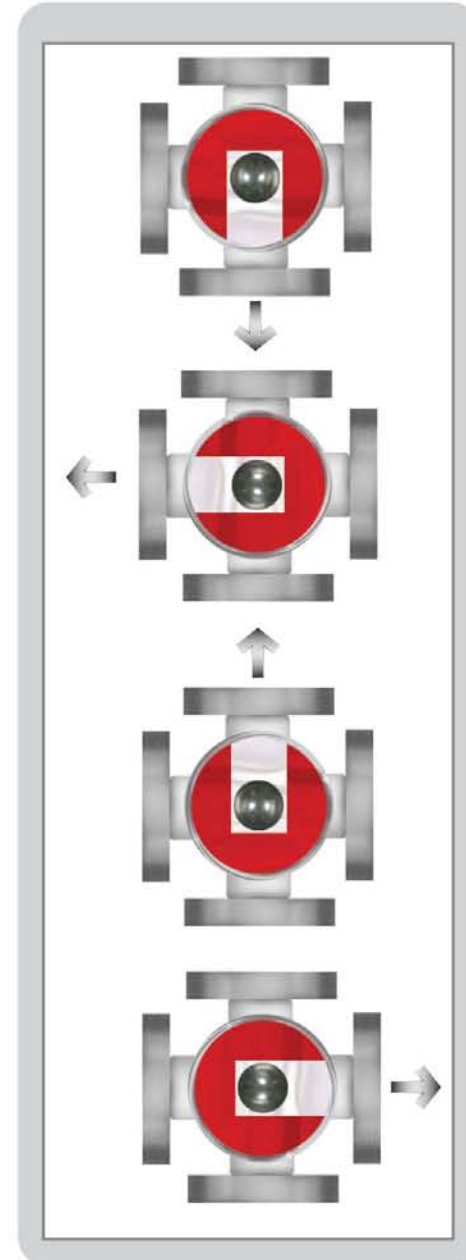
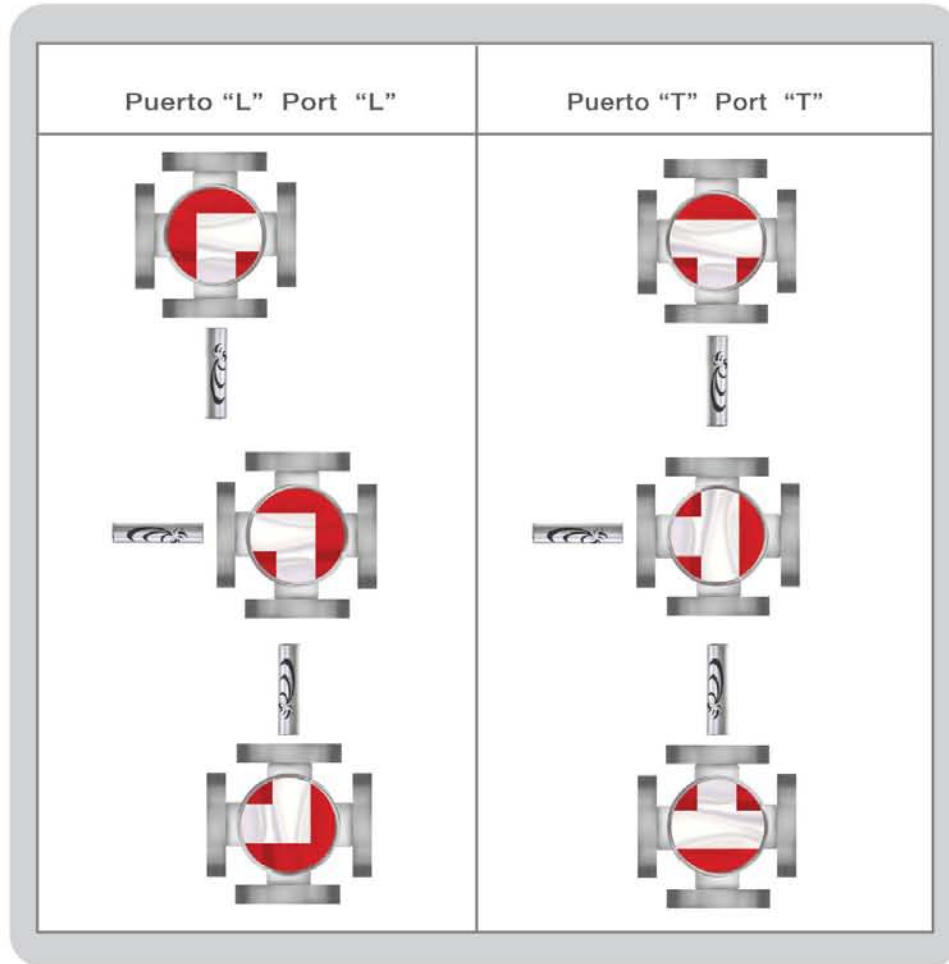

ENTRADA INFERIOR
5 LADOS ABIERTOS

BOTTOM ENTRY
5 WAYS OPENED

SERIES C-400 CRYOGENIC

*Esta válvula se puede automatizar con actuador eléctrico, neumático e hidráulico.

*This valve can be automated with an electric, pneumatic, or hydraulic actuator.



Latón / Brass	B283-C37700
Válvula / Valve	Presión de trabajo / Working pressure
Serie C-400 • Series C-400	600 psi

Acero Inoxidable /Stainless Steel	ASTM A351 CF8M		
Válvula / Valve	Presión de trabajo / Working pressure	Presión máx. de prueba / Max. Test pressure	Temperatura mín. de Operación / Temperature min. of operation
Serie C-400 • Series C-400	960 psi	1450 psi	-196°C

Dirección de flujo / Flow direction



Opcional / Optional

Lista de partes / List of components

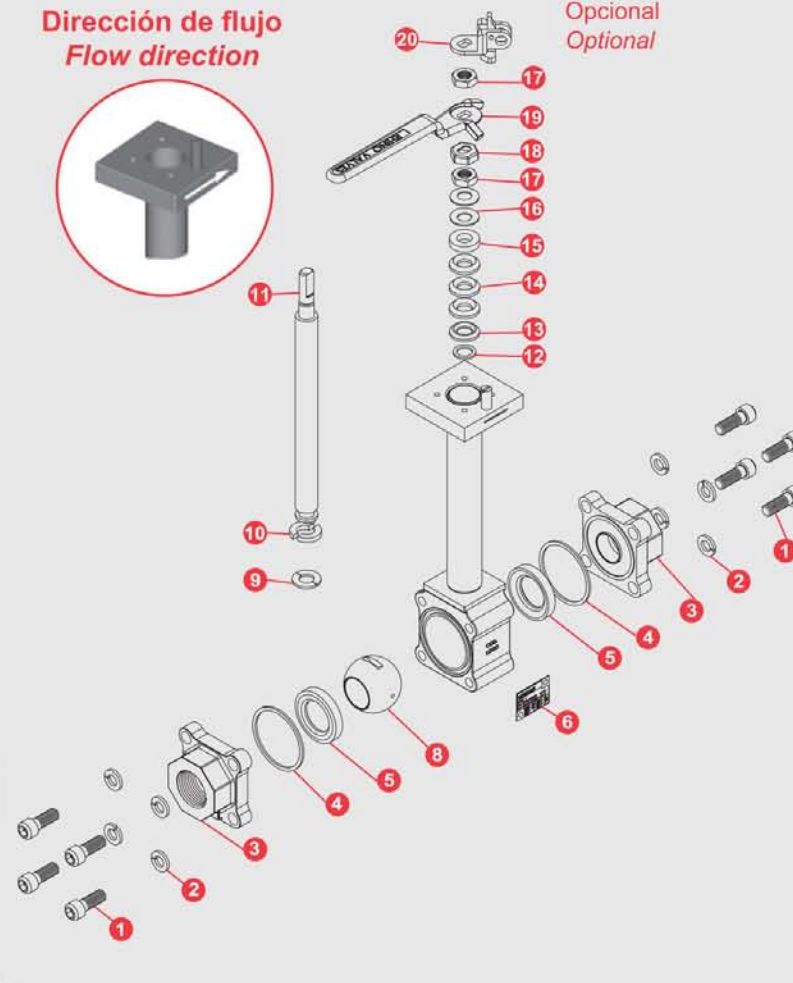

- 1 Tornillo del cuerpo • Body bolt
- 2 Roldana de presión • Lock washer
- 3 Tapa • Pipe end
- 4 Sello de cuerpo • Body seal
- 5 Asiento • Seal
- 6 Placa de identificación • ID plate
- 7 Cuerpo • Body
- 8 Bola • Ball
- 9 Separador partido • Half stem seal follower
- 10 Roldana partida • Half thrust bearing
- 11 Vástago • Stem
- 12 Roldana delgada • Flat thrust bearing
- 13 Seguidor inferior • Thrust bearing
- 14 Empaque Chevron • Chevron seal
- 15 Seguidor superior • Follower
- 16 Roldana concava • Belleville washer
- 17 Tuerca de vástago • Stem nut
- 18 Seguro para tuerca • Nut lock
- 19 Maneral • Handle
- 20 Dispositivo para candado • Locking device

Bola con orificio alivio / Ball with relief hole

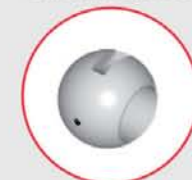

Materiales de asientos y sellos • Seat and seal materials

Asiento / Seat	Sello del cuerpo / Body seal	Sello del vástago / Stem seal
I PTFE + A. INOXIDABLE	G GRAFOIL	G GRAFOIL

SERIES C-400 CRYOGENIC

Válvula unidireccional libre de grasa, conexiones NPT, BSPP, BSPT, SW, BW, diseñada para operar a bajas temperaturas hasta -196° C. (servicio criogénico). Diseño de 3 piezas, extensión de vástago para una operación segura, disponible en materiales de latón. En medidas de 1/4" a 2" en paso reducido y en paso completo medidas de 1/2" a 2". Plato ISO 5211 superior para automatización, con orificio de alivio de presión en la bola.

Unidirectional ball valve, 3-piece design, with stem extension for a safe use, manufactured in brass with rust-resisting interiors and in stainless steel, oil free, designed for working at low temperatures until -196° C (Cryogenic services). Available in sizes from 1/4" to 2" in reduce bore and from 1/2" to 2" in full bore.

Plate ISO 5211 for automation, ball with relief hole. Connections NPT, BSPP, BSPT, SW and BW.

OPCIONES:

Dispositivo para candado; 3 vías; Multifill hasta -156°C
Automatización con actuador eléctrico ó neumático.
Extensión de Vástago atornillada

OPTIONS:

Locking device; 3 ways; Multifill operation up to -156°C
The valve can be automated with an electric or pneumatic actuator; Bolted stem extended.

Válvula Unidireccional • Unidirectional Valve

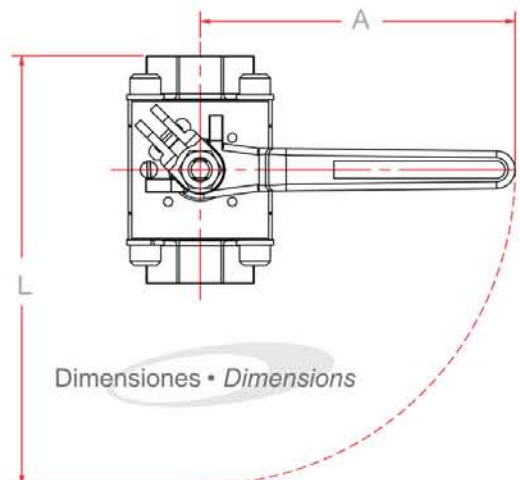
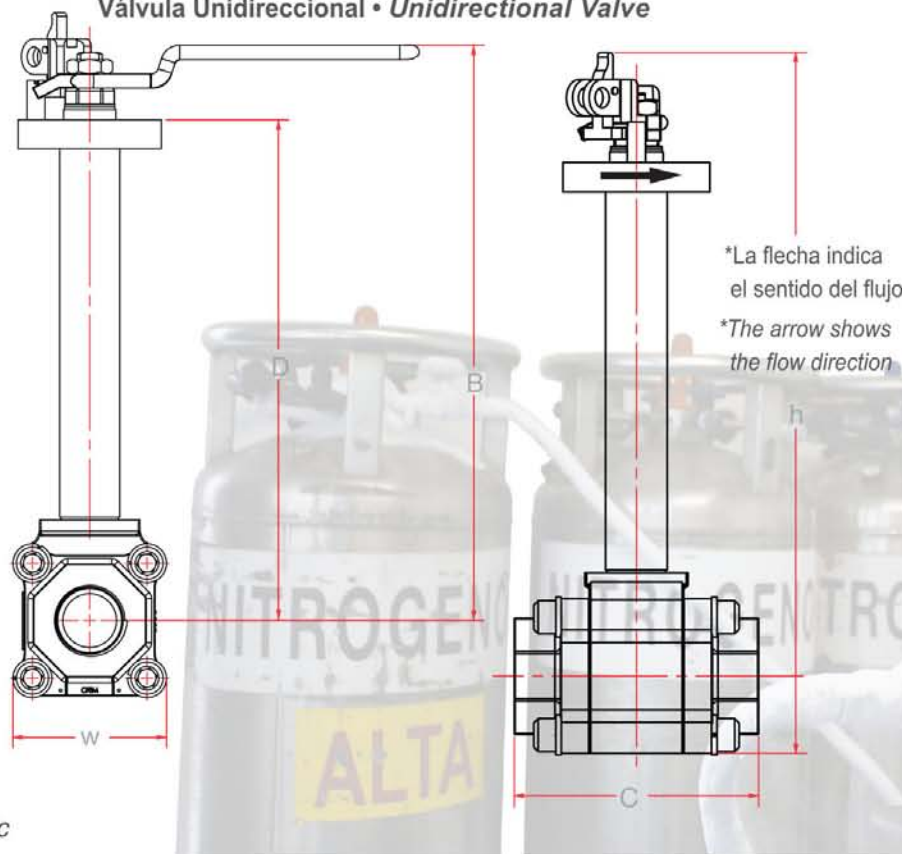

Criogénica Serie C-400 • Cryogenic Series C-400
Paso reducido • Reduced bore

Medida / Size	A	B	C	D	Paso Bore	Peso / Weight		Largo / Length	h	w
						kg	lb			
1/4	4.25	8.00	2.61	7.03	.440	1.250	2.700	5.56	8.88	1.75
1/2	4.90	8.00	2.61	7.03	.440	1.080	2.380	5.61	8.88	1.75
3/4	4.25	8.14	2.83	7.03	.560	1.450	3.100	5.67	9.14	2.00
1	5.75	9.14	3.72	7.79	.810	2.490	5.490	7.71	10.35	2.38
1 1/4	5.75	10.00	4.22	7.87	1.00	3.230	7.100	7.86	11.32	2.63
1 1/2	7.00	10.50	4.56	9.05	1.25	4.900	10.100	9.28	12.10	3.19
2	7.00	11.30	5.01	9.79	1.50	6.060	13.300	9.51	13.10	3.57

Nota: Dimensiones en pulgadas • Note: All dimensions in inch

SERIES C-15 CRYOGENIC



Válvula de bola unidireccional, libre de grasa, paso reducido, bridada, clase ANSI 150 para operar a bajas temperaturas hasta -196°C (Servicio criogénico). Diseño de 1 pza con tapón roscado y vástago extendido para una operación segura, construcción ligera en material de acero Inoxidable: disponible en diámetros de 1" a 6", maneral con provisión para candado, plato ISO 5211. Diseño de maneral corto para operar válvulas en medidas de 3" a 6".

Unidirectional ball valve, oil free, reduce bore, flanged class ANSI 150, designed for operation at low temperatures up to -196°C (cryogenic services). One-piece design with threaded plug and extended stem for a safe operation, light construction in stainless steel. Available in sizes from 1" to 6", ISO plate 5211, with locking device and short handle for operation with lever in sizes from 3" to 6".

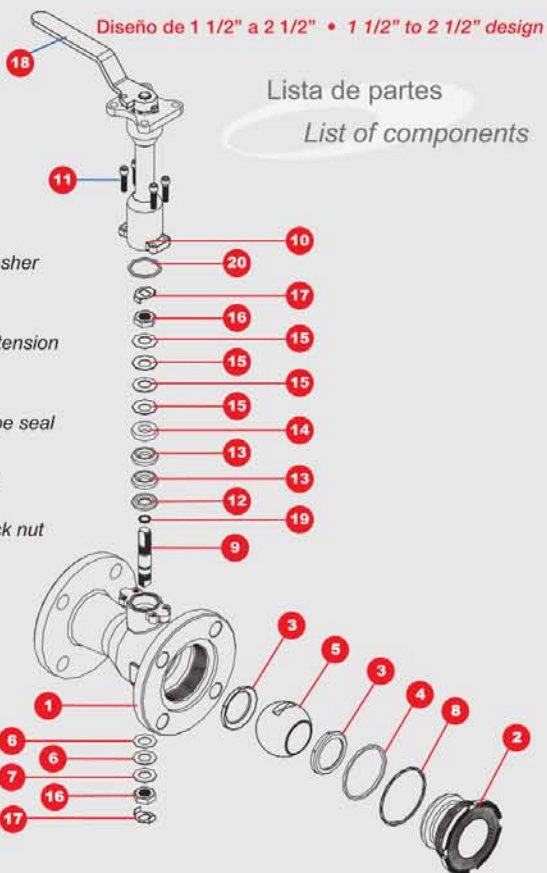

- 1 Cuerpo • Body
- 2 Tapón • Plug
- 3 Asiento • Seat
- 4 Sello de cuerpo • Body seal
- 5 Bola • Ball
- 6 Sello de vástago • Stem seal
- 7 Roldana de retención • Retaining washer
- 8 Aro sello de cuerpo • Body o-ring
- 9 Vástago • Stem
- 10 Extensión criogénica • Cryogenic extension
- 11 Tornillo base ISO • ISO base screw
- 12 Seguidor inferior • Thrust bearing
- 13 Empaque tipo chevron • Chevron type seal
- 14 Seguidor superior • Follower
- 15 Roldana cóncava • Belleville washer
- 16 Tuerca de vástago • Stem nut
- 17 Seguro para tuerca de vástago • Lock nut
- 18 Maneral • Handle
- 19 Aro sello de vástago • Stem o-ring
- 20 Sello criogénico • Cryogenic seal

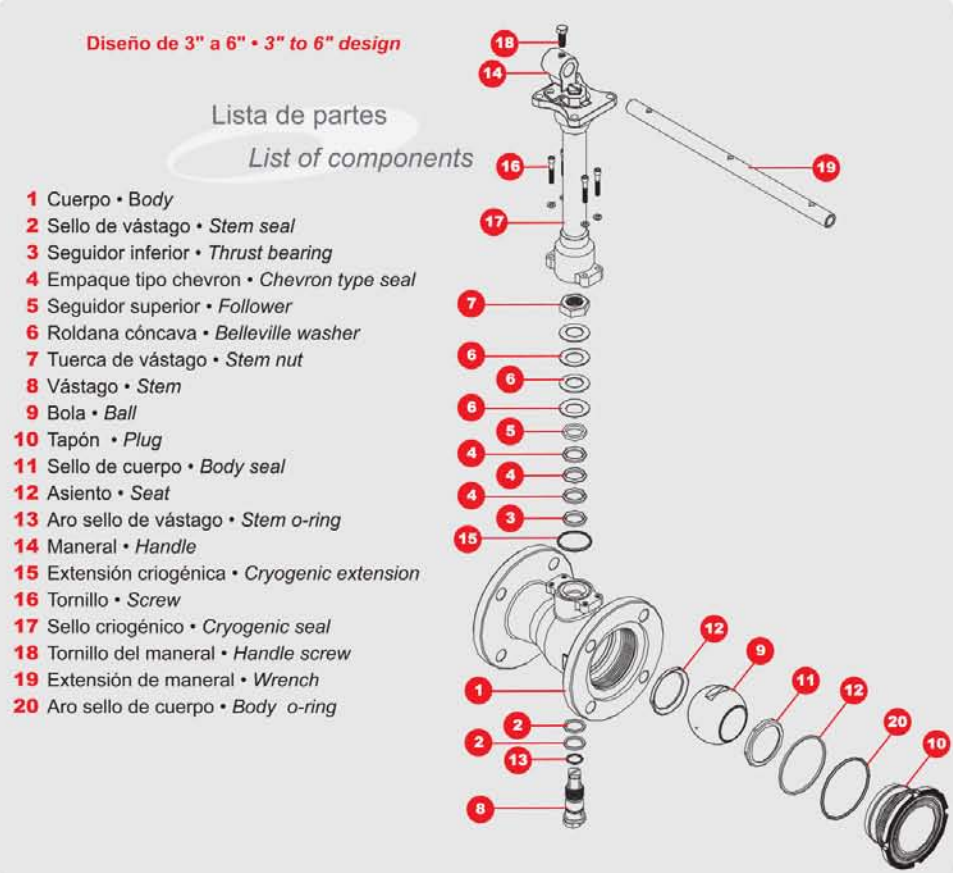

- 1 Cuerpo • Body
- 2 Sello de vástago • Stem seal
- 3 Seguidor inferior • Thrust bearing
- 4 Empaque tipo chevron • Chevron type seal
- 5 Seguidor superior • Follower
- 6 Roldana cóncava • Belleville washer
- 7 Tuerca de vástago • Stem nut
- 8 Vástago • Stem
- 9 Bola • Ball
- 10 Tapón • Plug
- 11 Sello de cuerpo • Body seal
- 12 Asiento • Seat
- 13 Aro sello de vástago • Stem o-ring
- 14 Maneral • Handle
- 15 Extensión criogénica • Cryogenic extension
- 16 Tornillo • Screw
- 17 Sello criogénico • Cryogenic seal
- 18 Tornillo del maneral • Handle screw
- 19 Extensión de maneral • Wrench
- 20 Aro sello de cuerpo • Body o-ring

SERIES C-15 CRYOGENIC

OPCIONES:

Automatización con actuador eléctrico
ó neumático

OPTIONS:

The valve can be Automated with an
electric or pneumatic actuator.

Materiales de asientos y sellos • *Seat and seal materials*

Asiento <i>Seat</i>	Sello del cuerpo <i>Body seal</i>	Sello del vástago <i>Stem seal</i>
PTFE + A. Inoxidable • <i>PTFE + Stainless steel</i>	M MULTIFIL	M MULTIFIL

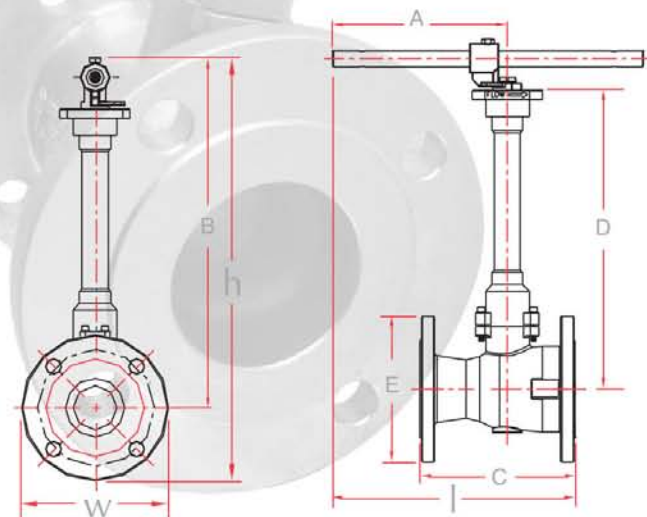
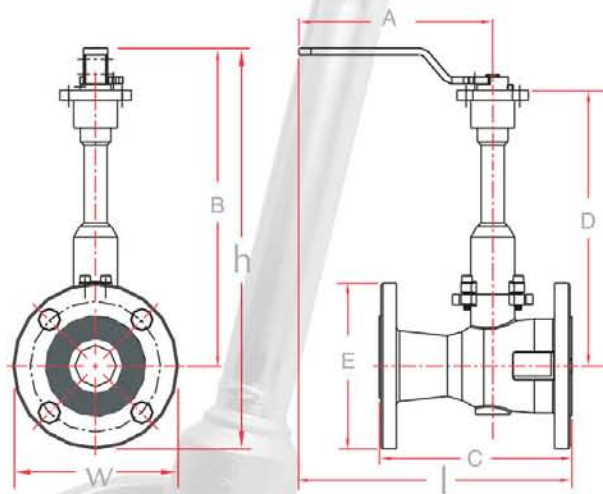

Válvula <i>Valve</i>	ANSI B16.34 <i>Clase • Class</i>	ASTM A351 CF8M		
		Presión de Trabajo <i>Working Pressure</i>	Presión Max.de Prueba <i>Max. Test Pressure</i>	Temperatura <i>Temperature</i>
Criogénica C-15 • <i>Cryogenic C-15</i>	150	275 psi	425 psi	-196° C

Criogénica Serie C -15 • *Series C -15 Cryogenic*

Medida / <i>Size</i>	A	B	C	D	E	Paso <i>Bore</i>	Peso / <i>Weight</i> kg / lb	Largo / <i>Length</i>	h	w
1 1/2	7.00	11.64	6.50	10.66	5.00	1.13	6.50 / 14.3	9.17	14.14	5.00
2	7.00	13.83	7.00	10.85	6.00	1.50	9.50 / 20.9	9.88	16.83	6.00
2 1/2	7.00	14.33	7.50	11.35	7.00	2.00	13.0 / 28.6	10.01	17.83	7.00

Nota: Dimensiones en pulgadas • *Note: All dimensions in inch*

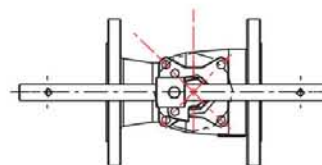

Dimensiones • *Dimensions*

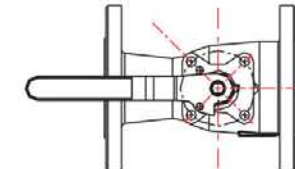

Criogénica Serie C -15 • *Series C -15 Cryogenic*

Medida / <i>Size</i>	A	B	C	D	E	Paso <i>Bore</i>	Peso / <i>Weight</i> kg / lb	Largo / <i>Length</i>	h	w
3	14.5	18.087	8	15.37	7.50	2.250	18.000 / 39.600	17.25	21.83	7.50
4	14.5	18.767	9	16.06	9.00	3.000	29.000 / 63.900	17.92	23.26	9.00
6	18.5	20.952	10.5	17.98	11.0	4.000	50.500 / 111.300	22.89	26.44	11.0

Nota: Dimensiones en pulgadas • *Note: All dimensions in inch*

SERIES S-400 CLAMP

Sanitaria Serie S-400 Materiales de sellos y asientos
 Series S-400 Sanitary Seat and seal materials

Asiento Seat	Sello del cuerpo Body seal	Sello del vástago Stem seal
T PTFE	T PTFE	R R-PTFE

Acero Inoxidable • *Stainless Steel*

ASTM A351 CF8M

Válvula Valve	ANSI B16.34 Clase • Class	Presión de trabajo Working pressure	Presión máx. de prueba Max. Test pressure
Sanitaria Serie S-400 Series S-400 Sanitary	400	960 psi	1450 psi



Sanitaria Serie S-400
 Series S-400 Sanitary

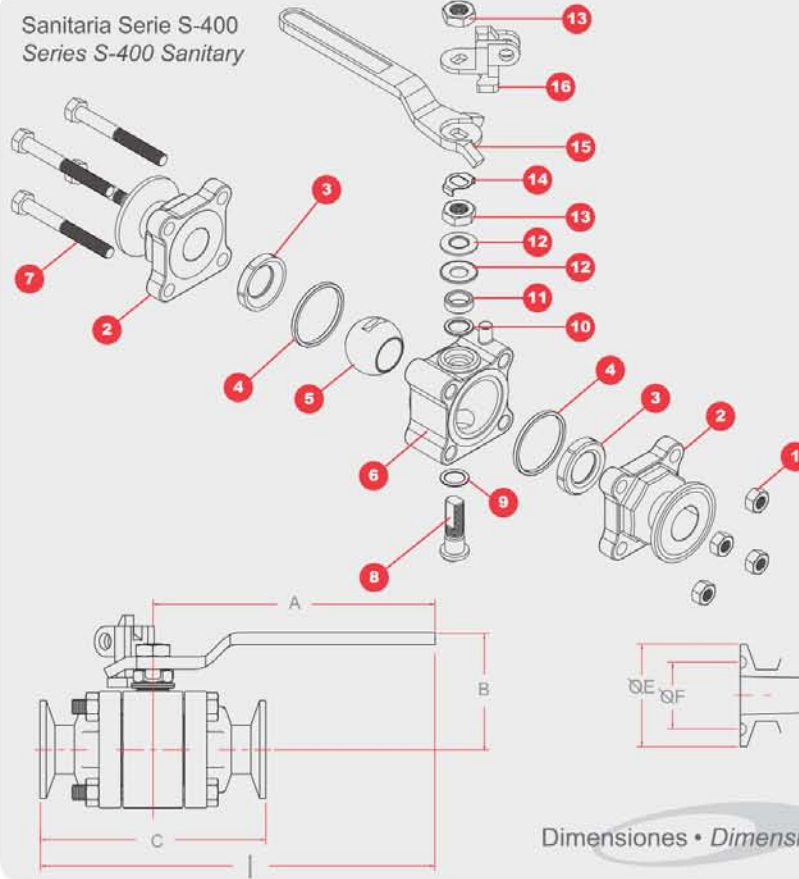

Lista de partes

List of components

- 1 Tuerca del cuerpo • *Body nut*
- 2 Tapa Clamp • *Clamp end*
- 3 Asiento • *Seat*
- 4 Sello de cuerpo • *Body seal*
- 5 Bola • *Ball*
- 6 Cuerpo • *Body*
- 7 Tornillo del cuerpo • *Body bolt*
- 8 Vástago • *Stem*
- 9 Roldana de vástago inferior • *Thrust bearing*
- 10 Roldana de vástago superior • *Stem seal*
- 11 Separador • *Follower*
- 12 Roldana cóncava • *Belleville washer*
- 13 Tuerca de vástago • *Stem nut*
- 14 Seguro para tuerca de vástago • *Lock nut*
- 15 Maneral • *Handle*
- 16 Dispositivo para candado (opcional)
 • *Locking device (optional)*

OPCIONES:

3 vías (Triclamp). Asientos de cavidad completa (Cavity filled)
 Plato ISO 5211. Automatización con actuador

OPTIONS:

3 ways (Triclamp). Cavity filled seats.
 ISO Plate 5211.
 Automation with electric or pneumatic Actuator.

Válvula de bola Serie 400, para uso sanitario con conexión Clamp, libre de grasa, diseño de 3 piezas, construcción robusta de acero inoxidable electropulido. Disponible en medidas de 1/2" a 2" en paso reducido.

Nota: No requiere de pasivación

Sanitary ball valve with Clamp Connection Series 400, oil free, 3-piece design, strong construction in electropolished stainless steel. Available in sizes from 1/2" to 2" in reduced bore.

Nota: No passivation required

Dimensiones • *Dimensions*

Medida / Size in	Sanitaria Serie S-400 • Series S-400 Sanitary							Paso Bore	Peso / Weight kg / lb	Largo / Length in	h	W	Ancho / Width in
	A	B	C	D	E	F							
1/2	4.3	1.65	3.50	1.51	.99	.75	0.438	0.620	1.400	5.63	2.64	1.75	
3/4	4.3	1.73	4.00	1.55	.99	.75	0.563	0.800	1.800	5.74	2.74	2.00	
1	5.75	2.4	4.50	2.17	1.98	1.71	0.813	1.530	3.400	7.57	3.59	2.38	
1 1/2	7.13	3.02	5.50	2.89	1.98	1.71	1.25	3.520	7.700	9.45	4.62	3.19	
2	7.13	3.15	6.25	3.07	2.51	2.20	1.5	4.590	10.100	9.65	5.00	3.57	

Nota: Dimensiones en pulgadas • *Note: All dimensions in inch*



Válvula de bola Clase 300, para uso sanitario con conexión Clamp, libre de grasa, diseño de 3 piezas en construcción robusta de acero inoxidable electropulido. Disponible en medidas de 2 1/2", 3" y 4" en paso reducido, con Plato ISO 5211.

Sanitary ball valve Clamp connection, oil free, three-piece design, strong construction in electropolished stainless steel. Available in 2 1/2", 3" and 4" in reduce bore, with ISO plate 5211.

SERIES S-45 CLAMP

Serie 45 Materiales de sellos y asientos • Series 45 Seat and seal materials

Asiento Seat	Sello del cuerpo Body seal	Sello del vástago Stem seal
T PTFE	T PTFE	R R-PTFE

Válvula Valve	Acero Inoxidable / Stainless Steel		
	ANSI B16.34 Clase • Class	Presión de trabajo Working pressure	Presión Máx. de prueba Max. Test pressure
Sanitaria Serie S-45 Series S-45 Sanitary	300	720 psi	1100 psi

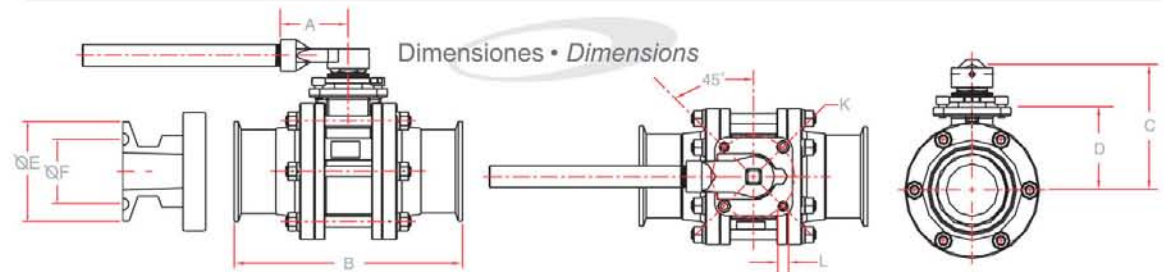

Sanitaria Serie S-45 • Series S-45 Sanitary

Medida / Size	A	B	C	D	E	F	Paso Bore	Peso / Weight kg / lb	K	L
2 1/2	7.35	6.50	3.98	3.06	3.04	2.78	2.000	10.500 / 23.100	2.75	M8
3	3.25	10.50	5.63	3.98	3.58	3.28	2.500	15.900 / 35.000	4.02	M10
4	3.25	12.50	6.23	4.58	4.68	4.34	3.250	26.300 / 57.900	4.02	M10

*Para Distancia total (B) diferentes de la tabla consultar en fábrica. *For total length of (B), please consult us.

Nota: Dimensiones en pulgadas • Note: All dimensions in inch

OPCIONES:

Dispositivo para candado
Asientos cavity filled
Enchafetado para control térmico
Automatización con actuador eléctrico o neumático.

OPTIONS:

Locking device
Cavity filled seats
Jacketed valve for thermic control.
The valve can be automated with an electric or pneumatic actuator.

TRUNNION BALL VALVES



FORJADAS
FORGED

FUNDIDAS
CAST

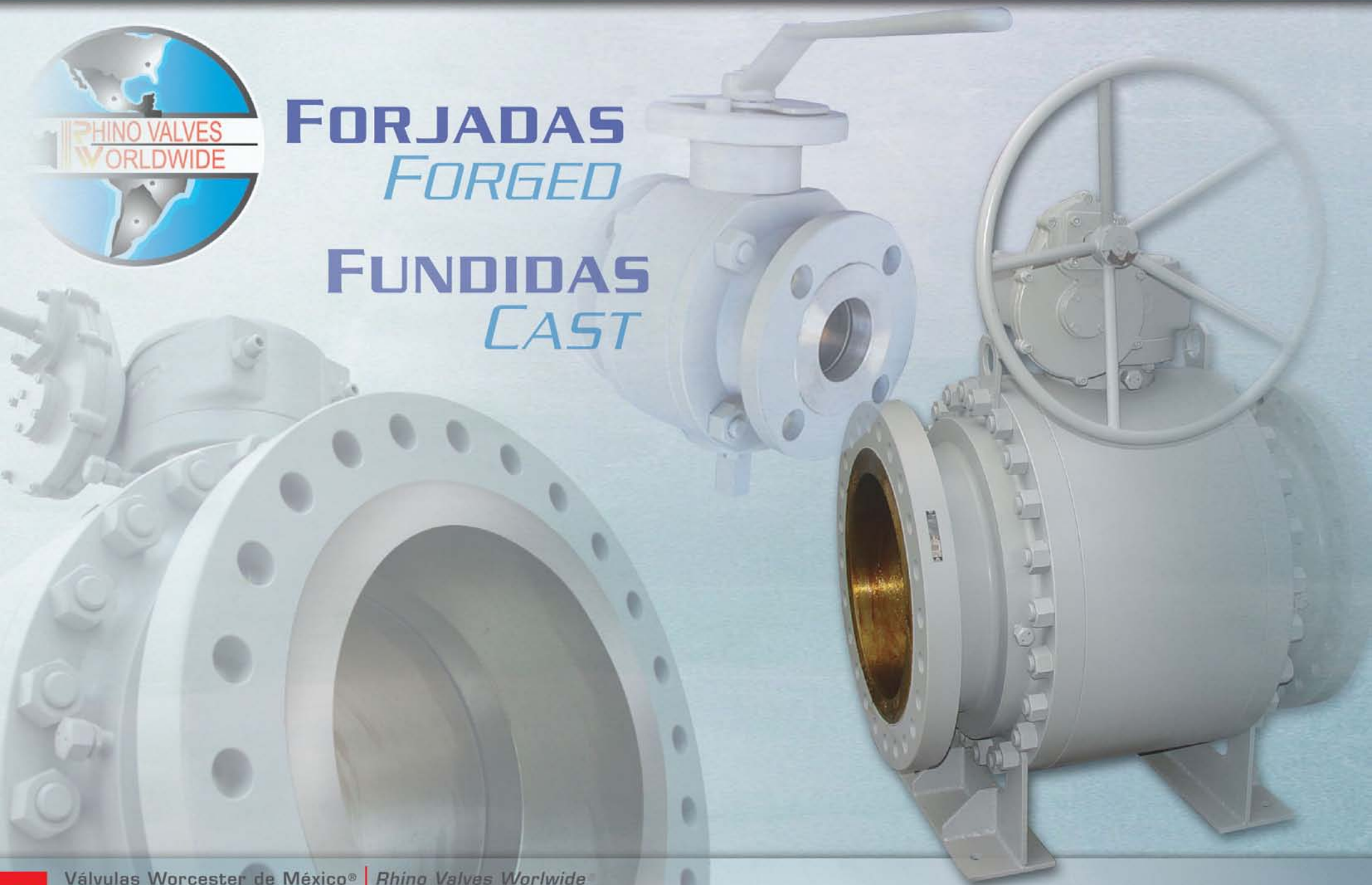

TRUNNION BALL VALVES

Doble sellado con O-rings, evita fuga en el área del vástago.
O-ring double sealing prevents leakage from stem area.

Combinación de O-ring y Gasket evita fuga entre la unión del cuerpo y las tapas.
Combination of O-ring and gasket prevents leakage from body joint area.

Asientos flotantes pre-cargados por resortes que aseguran el sellado aún a bajas presiones.
Floating seats provided with loaded springs assure sealing even at low pressures

Inserto del asiento suave ó sello metal-metal.
Soft seat inserts or metal-to-metal seal.

Sellado secundario, metal-metal: cuándo los sellos blandos han sido deteriorados por un evento de fuego, los asientos metálicos cierran el paso del fluido.
Additional metal-to-metal seal: when non-metal seal is damaged by fire, metallic seats shut off the fluid line.

Nota: se muestra válvula trunnion fundida de 2 piezas
Note: Cast Trunnion valve shown, 2-piece design

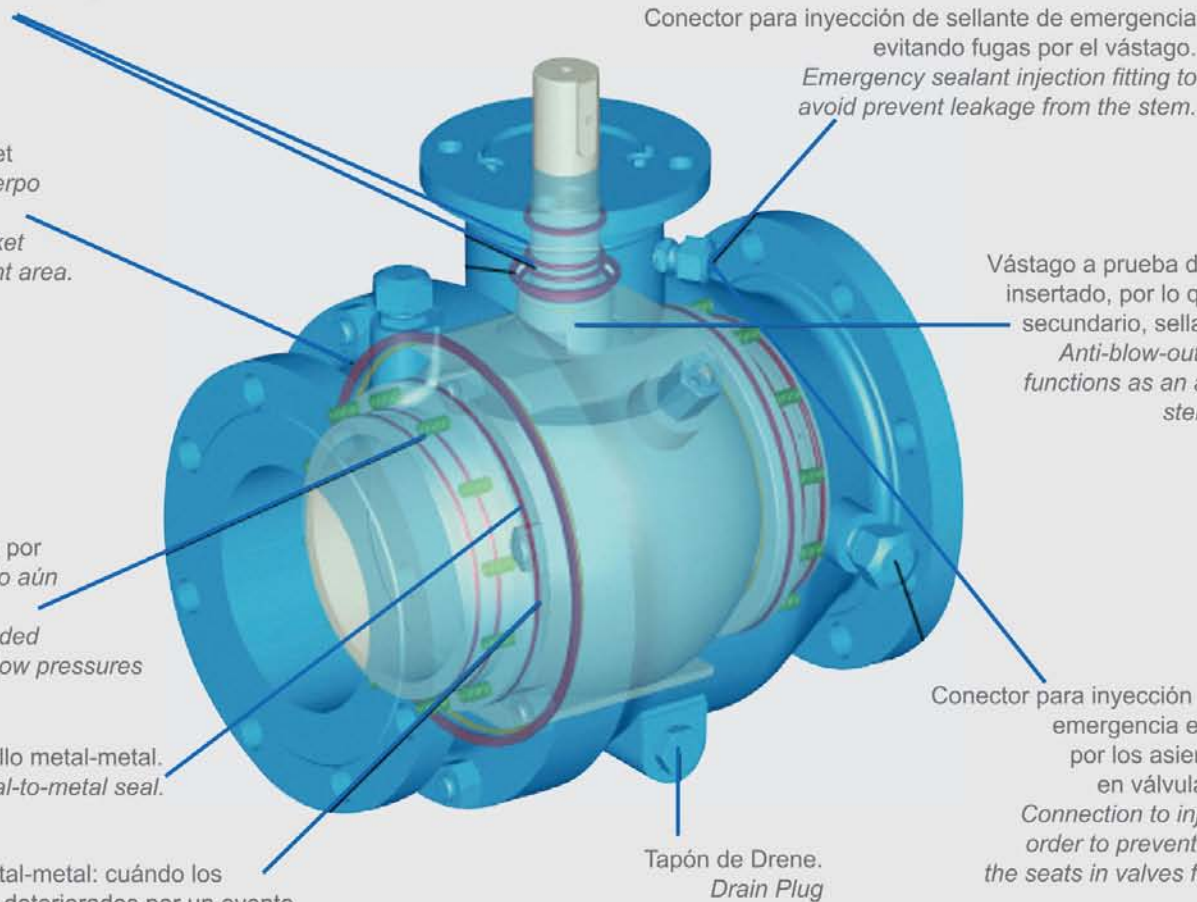

Conector para inyección de sellante de emergencia evitando fugas por el vástago.
Emergency sealant injection fitting to avoid prevent leakage from the stem.

Vástago a prueba de expulsión, internamente insertado, por lo que funciona como asiento secundario, sellando en cualquier presión.
Anti-blow-out stem, internally inserted, functions as an additional seal for assured stem sealing at all pressures.

Conector para inyección de sellante de emergencia evitando fugas por los asientos y vástago en válvulas de 6" a 48".
Connection to inject sealant in order to prevent leakage from the seats in valves from 6" to 48".

Tapón de Drene.
Drain Plug

TRUNNION BALL VALVES

SERIE 82, 83, 84, 85 y 86
 SERIE 82, 83, 84, 85 and 86



**FORJADO
 FORGED**

OPCIONES:

- Asiento metal-metal con diversos recubrimientos
- Diversos materiales de fabricación para cuerpo, asientos, vástago y muñon
- Automatización con Actuador eléctrico o neumático
- Diversos materiales de insertos del asiento

Válvula de bola Guiada (Trunnion)

Válvula de bola montada sobre muñon de paso completo y continuado con doble bloqueo y purga (Double Block and Bleed), aprueba de fuego (Fire Safe), diseño para control de emisiones fugitivas.

Calificada para todos los servicios de Petróleo y gas incluyendo servicio amargo y para baja temperatura, manufacturada en materiales de acero al carbón Forjado (cuerpo de 3 piezas o cuerpo integral soldado de una pieza), acero al carbón Fundido (cuerpo de 2 piezas), acero de bajo carbono LF2 (cuerpo de 3 piezas y cuerpo integral soldado de 1 pieza), así como materiales especiales bajo requerimiento. Cuenta con un recubrimiento de Níquel Electroless (ENP de 0.003" mm de espesor) en bola, vástago y asientos. Disponible en medidas de 2" a 48" en diferentes Clases: ANSI 150#, 300#, 600#, 900#, 1500# y 2500# en conexiones bridadas (RF y RTJ) y conexión soldable a tope (BW).

Las Válvulas de bola guiada cuentan con asientos únicos con resortes precargados que permiten el sellado hermético incluso a baja presión de trabajo. El inserto del asiento estándar es de PTFE reforzado en medidas de 2" a 4" y de Nylón en medidas de 6" a 48" con opción de manejar otros materiales bajo requerimiento como asientos metal-metal con diferentes recubrimientos como Stellite, Carburo de Tungsteno, Carburo de Cromo en bola, vástago, muñon y asiento con 0.006" de espesor para fluidos altamente abrasivos (Consultar en Planta).

Las Válvulas de 2" a 4" son operadas con palanca y en medidas de 6" en adelante con operador de engranes. Fabricadas y diseñadas bajo la normatividad NACE MR-0175 API 6D, (ISO-14313), Fire safe API 607 (BS-6755, ISO 10497), API 598, ASME B16.5, ASME B16.25 y ASME B16.34.



**FUNDIDO
 CAST**

OPTIONS:

- Metal-to-Metal seats with several coverings*
- Several materials for body, stem, trunnion, and seats*
- Automation with an electric or pneumatic actuator*
- Several materials for seat inserts*

**CUERPO SOLDADO
 WELDED BODY**



Trunnion Mounted Ball Valves

Trunnion mounted ball valves, full bore and through conduit, Double Block and Bleed, Fire Safe, fugitive emissions control design.

Qualified for all petroleum and gas services including sour services and low temperatures, manufactured in forged carbon steel (three-piece design and or one piece welded body), cast carbon steel (two-piece), low carbon steel LF2 (three-piece design and /or one-piece welded body), and special material on request. Ball, stem, and seats are provided with an Electroless Nickel Plating (ENP of 0.003" or 0.013 mm thickness).

Valves are available in sizes from 2" to 48" in different classes: ANSI 150#, 300#, 600#, 900#, 1500# and 2500# with flanged (RF and RTJ) and Buttwelded connections (BW). The Trunnion ball valves are equipped with unique spring-loaded seats which assure a hermetic sealing even at lower pressures.

More over, it is provided with a seat insert as standard in Reinforced PTFE in sizes from 2" to 4" and in Nylon from 6" to 48"; the customer has the option to get other material as per request, such as metal-to-metal seats with several coverings like Stellite, Tungsten Carbide, and Chrome Carbide for ball, stem, trunnion, and seat with 0.006" of thickness for highly abrasive fluids (please consult us).

In sizes from 2" to 4". The Trunnion ball valves are designed and manufactured in accordance with the norms NACE MR-0175 API 6D, (ISO-14313), Fire safe API 607 (BS-6755, ISO 10497), API 598, ASME B16.5, ASME B16.25 and ASME B16.34.

Especificaciones de Materiales Trunnion Serie 82, 83, 84 85 y 86 Forjada (Atornillada ó Soldada)

Partes	Estandar	Acero Inoxidable	Servicio a Baja Temperatura
Cuerpo	ASTM A105	ASTM A 182-F316	ASTM A350-LF2
Conexión	ASTM A105	ASTM A 182-F316	ASTM A350-LF2

Especificaciones de Materiales Trunnion Serie 82, 83, 84 85 y 86 Forjada (Atornillada)

Partes	Estandar Servicio Amargo	Acero Inoxidable	Servicio a Baja Temperatura
Cuerpo	ASTM A216-WCB	ASTM A 351-CF8M	ASTM A352-LCB
Conexión	ASTM A216-WCB	ASTM A 351-CF8M	ASTM A352-LCB

Especificaciones de Materiales Trunnion Serie 82, 83, 84 85 y 86 Forjada y Fundida (Todas)

Partes	Estandar	Acero Inoxidable	Servicio a Baja Temperatura
Bola	ASTM A105/ENP	ASTM A182-F316	ASTM A350-LF2/ENP
Asiento ensamblado	Ensamblado	Ensamblado	Ensamblado
Inserto del Asiento	25% Fibra de Vidrio PTFE	25% Fibra de Vidrio PTFE	NYLON
Anillo del Asiento	ASTM A105/ENP	ASTM A182-F316	ASTM A350-LF2/ENP
Vástago	AISI 4140/ENP	ASTM A182-F316	ASTM A350-LF2/ENP
Guía de Alineación del Muñon	ASTM A182-F316	ASTM A182-F316	ASTM A182-F316
Guía	ASTM A182-F316	ASTM A182-F316	ASTM A182-F316
Soporte de Muñon	ASTM A216-WCB/ENP	ASTM A 351-CF8M	ASTM A 352-LCB/ENP
Gasket	316+Grafito	316+Grafito	316+Grafito
Gasket del Cuerpo	316+Grafito	316+Grafito	316+Grafito
Gasket	316+Grafito	316+Grafito	316+Grafito
Espaciador	PTFE	PTFE	PTFE
Gasket a Prueba de Fuego	316+Grafito	316+Grafito	316+Grafito
Tapa prensa-estopa	ASTM A105	ASTM A182-F316	ASTM A350-LF2
Bridada Superior	ASTM A105	ASTM A182-F316	ASTM A350-LF2
Roldana de Apoyo	316+PTFE+MoS2	316+PTFE+MoS2	316+PTFE+MoS2
Cojinete	316+PTFE+MoS2	316+PTFE+MoS2	316+PTFE+MoS2
Seguidor de Asiento	ASTM A105/ENP	ASTM A182-F316	ASTM A350-LF2/ENP

Partes	Estandar	Acero Inoxidable	Servicio a Baja Temperatura
Válvula de Purga	Ensamble	Ensamble	Ensamble
Purga	Acero Inoxidable	Acero Inoxidable	Acero Inoxidable
Resorte de Asiento	Inconel X-750	Inconel X-750	Inconel X-750
Resorte Anti-estático	Acero Inoxidable	Acero Inoxidable	Acero Inoxidable
Embolo Anti-estático	ASTM A182-F316	ASTM A182-F316	ASTM A182-F316
O-Ring	NBR	NBR	NBR VITON/BUNA N
O-Ring	NBR	NBR	NBR VITON/BUNA N
O-Ring	NBR	NBR	NBR VITON/BUNA N
O-Ring	NBR	NBR	NBR
Birlo de Cuerpo	ASTM A193-B7	ASTM A193-B78	ASTM A320-L7M
Tuerca de Cuerpo	ASTM A194-2H	ASTM A194-8	ASTM A194-7M
Tornillo	Acero al carbón	Acero Inoxidable	ASTM A320-L7M
Tornillo	Acero al carbón	Acero Inoxidable	ASTM A320-L7M
Guía de prensa-estopa	Acero al carbón	Acero Inoxidable	Acero al carbón
Llave	Acero al carbón	Acero Inoxidable	ASTM A182-F304
Guía de resorte	Acero al carbón	Acero Inoxidable	Acero al carbón
Inyector de asiento	Ensamble	Ensamble	Ensamble
Inyector de Vástago	Ensamble	Ensamble	Ensamble

Trunnion Serie 82, 83, 84 85 y 86 Forged material specifications (Bolted & Welded)

Part	Standard	Stainless Steel	Low Temperature Service
Body	ASTM A105	ASTM A 182-F316	ASTM A350-LF2
End Connection	ASTM A105	ASTM A 182-F316	ASTM A350-LF2

Trunnion Serie 82, 83, 84 85 y 86 Forged material specifications (Bolted)

Part	Standard	Stainless Steel	Low Temperature Service
Body	ASTM A216-WCB	ASTM A 351-CF8M	ASTM A352-LCB
End Connection	ASTM A216-WCB	ASTM A 351-CF8M	ASTM A352-LCB

Trunnion Serie 82, 83, 84 85 y 86 Forged material specifications (All)

Part	Standard	Stainless Steel	Low Temperature Service
Ball	ASTM A105/ENP	ASTM A182-F316	ASTM A350-LF2/ENP
Seat Assembly	Assembled	Assembled	Assembled
Seat Insert	25% Glass filled PTFE	25% Glass filled PTFE	NYLON
Seat Ring	ASTM A105/ENP	ASTM A182-F316	ASTM A350-LF2/ENP
Stem	AISI 4140/ENP	ASTM A182-F316	ASTM A350-LF2/ENP
Trunnion Alignment Pin	ASTM A182-F316	ASTM A182-F316	ASTM A182-F316
Shim	ASTM A182-F316	ASTM A182-F316	ASTM A182-F316
Trunnion Support	ASTM A216-WCB/ENP	ASTM A 351-CF8M	ASTM A 352-LCB/ENP
Gasket	316+Graphite	316+Graphite	316+Graphite
Body Gasket	316+Graphite	316+Graphite	316+Graphite
Gasket	316+Graphite	316+Graphite	316+Graphite
Spacer	PTFE	PTFE	PTFE
Firesafe Gasket	316+Graphite	316+Graphite	316+Graphite
Top Flange	ASTM A105	ASTM A182-F316	ASTM A350-LF2
Thrust Washer	ASTM A105	ASTM A182-F316	ASTM A350-LF2
Bearing	316+PTFE+MoS2	316+PTFE+MoS2	316+PTFE+MoS2
Seat Follower	ASTM A105/ENP	ASTM A182-F316	ASTM A350-LF2/ENP
Vent Valve	Assembly	Assembly	Assembly

Partes	Estandar	Acero Inoxidable	Servicio a Baja Temperatura
Drain	Stainless Steel	Stainless Steel	Stainless Steel
Seat Spring	Inconel X-750	Inconel X-750	Inconel X-750
Grounding Spring	Stainless Steel	Stainless Steel	Stainless Steel
Grounding Plunger	ASTM A182-F316	ASTM A182-F316	ASTM A182-F316
O-Ring	NBR	NBR	NBR VITON/BUNA N
O-Ring	NBR	NBR	NBR VITON/BUNA N
O-Ring	NBR	NBR	NBR VITON/BUNA N
O-Ring	NBR	NBR	NBR
Body Stud	ASTM A193-B7	ASTM A193-B78	ASTM A320-L7M
Body Nut	ASTM A194-2H	ASTM A194-8	ASTM A194-7M
Screw	Carbon Steel	Stainless Steel	ASTM A320-L7M
Screw	Carbon Steel	Stainless Steel	ASTM A320-L7M
Gland Pin	Carbon Steel	Stainless Steel	Carbon Steel
Key	Carbon Steel	Stainless Steel	ASTM A182-F304
Spring Pin	Carbon Steel	Stainless Steel	Carbon Steel
Seat Injection	Assembly	Assembly	Assembly
Stem Injection	Assembly	Assembly	Assembly

TRUNNION BALL VALVES

Especificación de materiales Trunnion
Serie 82, 83, 84, 85 y 86 forjada (Metal - Metal)

*Trunnion Series 82, 83, 84, 85 & 86 forged
material specifications (Metal - Metal)*

No.	PART NAME	MATERIAL	MATERIAL	REMARKS
1	Body	Cuerpo	ASTM A105	
2	Bonnet bolt	Tornillos del Bonete	ASTM A193 B7M	
3	Bonnet Nut	Tuercas del Bonete	ASTM A193 2HM	
4	Bonnet Gasket	Empaque del bonete	Graphite+SS304	
5	Trunnion Bearing	Rodamiento del Muñon	AISI 304	nitriding
6	Bonnet	Bonete	ASTM A105	
7	Ball	Bola	AISI A105+tungsten	Carbide
8	Seat Ring	Resorte del Asiento	AISI 410+tungsten	Carbide
9	Spring	Resorte	INCOMEL x-750	
10	Seat	Asiento	ASTM A105+ENP	
11	Seat Gasket	Asiento de la Junta	Graphite	
12	Stem Bearing	Rodamiento del Vástago	AISI 304	nitriding
13	Stem	Vástago	AISI 410+tungsten	Carbide
14	Gland Gasket	Empaque	Graphite+SS304	
15	Gland Screw	Tornillo	ASTM A193+B7M	
16	Connector	Conector	ASTM A105+ENP	
17	Stem Packing	Empaque del vástago	Graphite	
18	Yoke	Yugo	ASTM A105	
19	Gear Box	Caja de Engranajes	Ductile Iron	
20	Venting	Respirador	AISI 1025	
21	Drain Plug	Tapon de Drenaje	AISI 1025	
22	Trunnion	Muñon	ASTM A105+ENP	

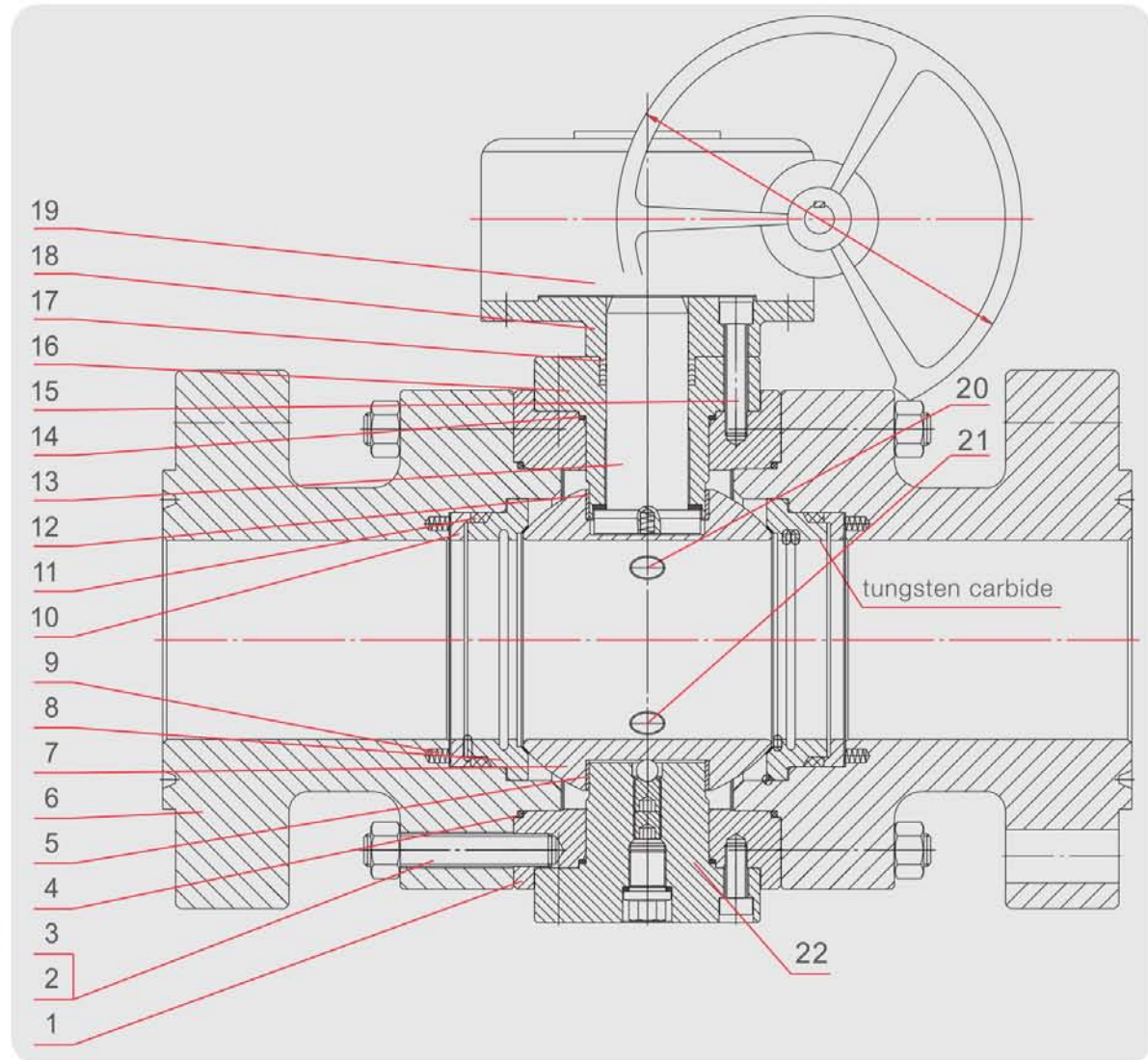

VÁSTAGO A PRUEBA DE EXPULSIÓN

La bola y el vástago son partes separadas. La parte inferior del vástago esta diseñado con un collar integral que lo hace a prueba de expulsión.

DISPOSITIVO ANTI-ESTÁTICO

Este dispositivo anti-estático es una característica estándar de las Válvulas de bola Guiada tipo Trunnion marca Rhino. Mediante un émbolo precargado por un resorte se asegura la continuidad eléctrica entre la bola, el vástago y el cuerpo, evitando “descargas electricas” al girar el vástago durante las operaciones de abrir / cerrar de la válvula.

ANTI-BLOW-OUT STEM

The stem and the ball are separated parts. The lower end of the stem is designed with an integral collar to be blow-out-proof.

ANTISTATIC DEVICE

The antistatic device is a standard feature of RHINO ball Valves. A spring-loaded pin assures the electrical continuity between ball, stem and body so as to avoid Sparks when turning the stem to open and close the valve.

DISEÑO FIRE SAFE (APRUEBA DE FUEGO)PREVENCIÓN DE FUGAS EXTERNAS

La posible fuga por el área del vástago y cuerpo se evita gracias a un doble sellado de O-ring y un sellado tipo Gasket.

Despues de que un evento de fuego ha deteriorado o destruido los O-Ring y los sellos de Gasket de vástago, el empaque “Fire Safe” y el Gasket del cuerpo funcionan para prevenir la fuga del fluido.

FIRE SAFE DESIGN EXTERNAL LEAKAGE PREVENTION

Leakage from the valve stem area is prevented by double sealing with 2 O-Rings and Gland Gasket. Leakage through the valve body joint is also blocked by double sealing with O-Ring and Body Gasket. After a fire has deteriorated O-Rings Gland Gasket, Body Gasket and stem fire safe packing are the measure that prevents external fluid leakage.

DISEÑO FIRE SAFE (APRUEBA DE FUEGO) PREVENCIÓN DE FUGA INTERNA

Cuando los componentes no-metálicos (O-Ring, inserto de asiento y espaciador) se deterioran en un evento de fuego, el extremo del asiento metálico impulsado por sus resortes hace contacto con la bola, cerrando el paso del fluido para minimizar la fuga a través del paso de la válvula. Así mismo, el empaque de grafito flexible del asiento será comprimido por éste para prevenir fuga del fluido entre el cuerpo de la válvula y el asiento.

FIRE SAFE DESIGN INTERNAL LEAKAGE PREVENTION

When non-metal materials such as O-Ring, seat insert and spacer are decomposed or deteriorated by fire, the Edge of the metal seat preloaded by the seat Springs comes into contac with the Ball to shut off line fluid to minimize internal leakage through the valve bore. Also the fire flexible graphite seat packing will be compressed by the seat spring to prevent fluid leakage between the body and seat.

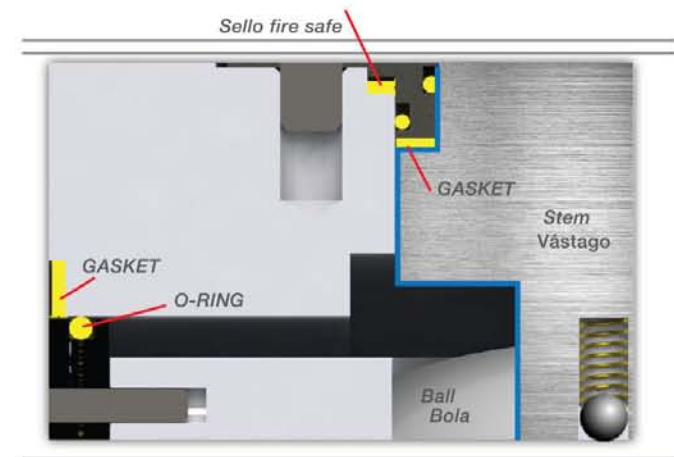
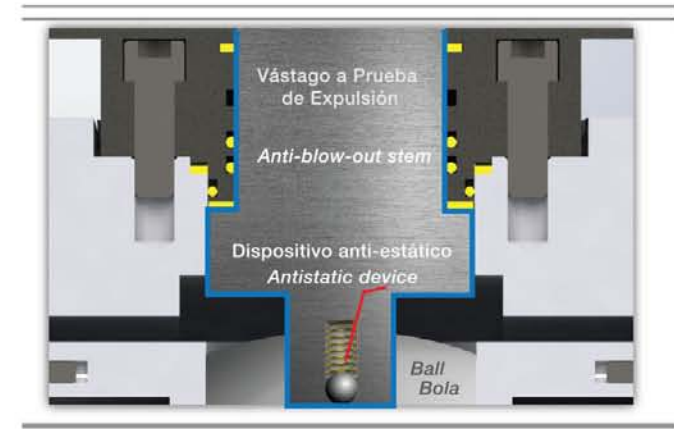

Fire safe paking / Empaque fire safe



SISTEMA DE INYECCION DE SELLANTE DE EMERGENCIA

En las válvulas de bola guiada tipo Trunnion marca RHINO en medidas de 6" y mayores, se incluyen conectores de inyección de sellante de ambos asientos y vástago. Cuando los sellos del asiento ó los O-Ring del vástago se deterioran en un evento de fuego o por otras causas accidentales, se puede evitar la fuga inyectando sellante en estos conectores, los cuales tienen instalados internamente, una válvula check secundaria que respalda el sellado.

EMERGENCY SEALANT INJECTION SYSTEM

For 6 inch and bigger RHINO Trunnion mounted ball valves, sealant injection fittings are installed on both stem and seats. When the sealing materials (seat or stem O-Ring) are damage or decomposed by fire or other accidental causes, leakage from the seat and stem can be prevented by injection of sealant into these fittings which have internally installed a second check valve to provide backup sealing.

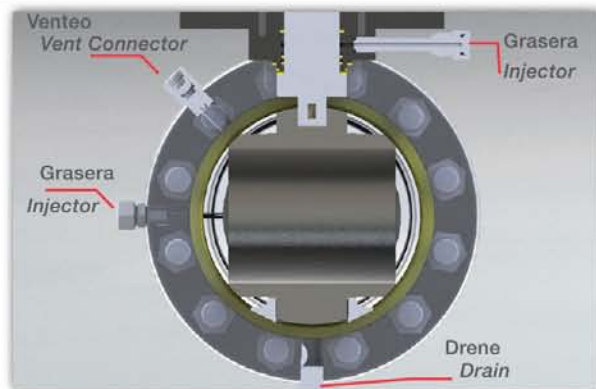

DOBLE BLOQUEO Y PURGA

Cada asiento de la bola cierra el paso del fluido en la línea, independiente de la dirección de esta, (aguas arriba aguas abajo) permitiendo una operación de doble bloqueo. Cuando se aplica presión simultáneamente en ambos lados de la bola en posición cerrada, la cavidad del cuerpo y del puerto de la válvula están aislados uno el otro, así el residuo del fluido acumulado en la cavidad del cuerpo puede purgarse a través del conector del drenaje.

DOUBLE BLOCK AND BLEED

Each ball seats shut off the line fluid independently, allowing double block operation. When the pressure is simultaneously applied on both sides of the ball in closed position, the valve bore and the body cavity can be released through the drain plug.

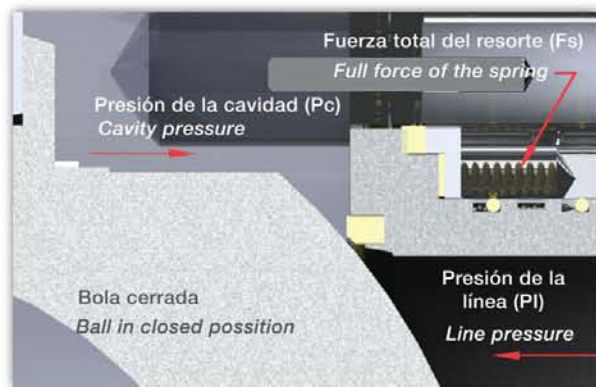

ALIVIO DE PRESION DE LA CAVIDAD EL CUERPO

Cuando la presión en la cavidad (P_c) es menor a la presión del resorte (F_s) y la presión a la línea (P_l), se asegura el contacto entre la bola y el inserto del asiento para un sellado hermético. Cuando la Presión en la cavidad es mayor que la presión del resorte y de la línea, se acciona permitiendo que el asiento de la válvula ligeramente se desplace separandose en la superficie de la bola, descargando así la sobre-presión hacia la línea, restableciendo el equilibrio de presión entre la cavidad y la línea.

CAVITY PRESSURE RELIEF

When cavity pressure (P_c) is higher than seat spring (F_s) and line pressure (P_l), the self relieving action allows that valve seat will move slightly away from the ball surface, therefore any over pressure acting in the body cavity is discharged into the line to restore the balance between the body cavity and line (either upstream or Downstream).

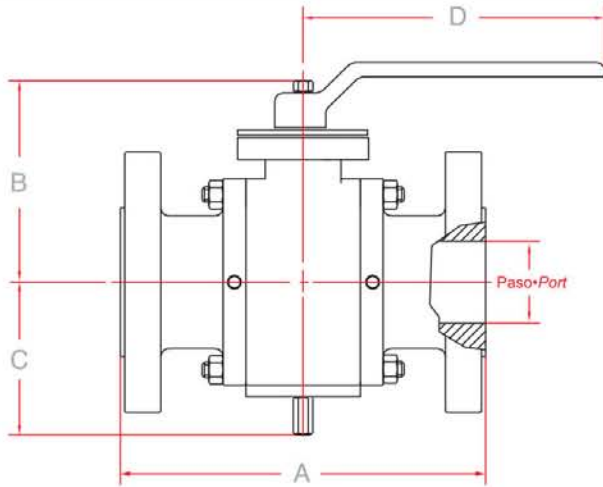

Dimensiones • Dimensions

Serie 82 (Clase 150) • Series 82 (Class 150)

Medida / Size	Paso / Bore mm	A (mm)	B (mm)	C (mm)	D (mm)	Peso / Weight kg
2	51	178	200	110	265	30
3	76	203	300	126	285	60
4	102	229	315	165	285	92
6	152	394	335	165	*300	190
8	203	457	405	200	*300	345
10	254	534	427	220	*300	495
12	305	610	465	262	*500	705
14	337	686	506	293	*600	859
16	387	762	622	341	*600	1020
18	438	864	666	92	*600	1440
20	489	914	730	435	*600	1918
22	540	991	833	480	*600	2352
24	591	1067	895	518	*800	2803
26	635	1143	900	535	*800	3200
28	686	1245	935	542	*800	4045
30	737	1295	1010	605	*800	4820
32	781	1372	1060	650	*800	5490
34	832	1473	1077	650	*800	6704
36	876	1524	1115	700	*800	7615
40	978	1727	1400	865	*800	11027
42	1022	1855	1598	900	*800	12110
48	1168	2134	1722	1042	*800	18360

* Válvula con caja de engranes • Valve with gear box

Válvula Forjada (Cuerpo atornillado ó Cuerpo Integral Soldado)
Forged Body Valves (Bolted or Welded Body)

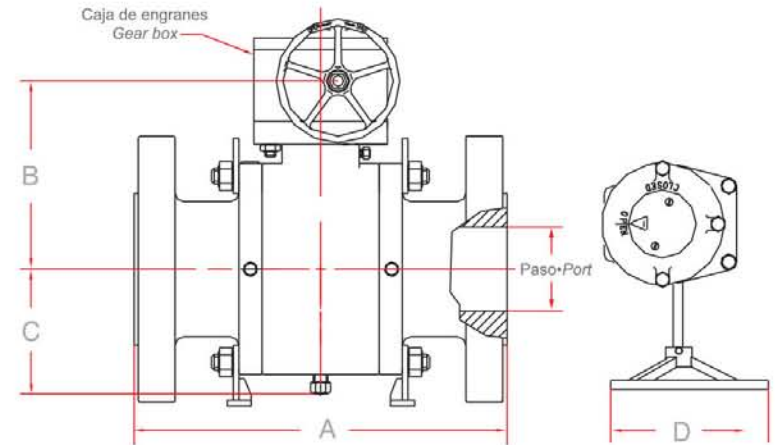

Serie 83 (Clase 300) • Series 83 (Class 300)

Medida / Size	Paso / Bore mm	A (mm)	B (mm)	C (mm)	D (mm)	Peso / Weight kg
2	51	216	206	113	265	31
3	76	283	315	129	400	69
4	102	305	330	169	750	110
6	152	403	345	148	*300	211
8	203	502	415	185	*300	376
10	254	568	427	226	*400	540
12	305	648	465	269	*500	763
14	337	762	519	300	*600	900
16	388	838	638	350	*600	1300
18	438	914	683	402	*600	1715
20	489	991	748	446	*600	2090
22	540	1092	854	492	*600	2220
24	591	1143	917	531	*800	2890
28	686	1346	958	556	*800	4575
30	737	1397	1035	620	*800	5590
32	781	1524	1087	666	*800	6240
34	832	1626	1104	666	*800	7370
36	876	1727	1143	718	*800	8435
40	978	1930	1435	887	*800	11200
42	1022	2032	1638	923	*800	13050
48	1168	2692	1765	1068	*800	19000

Nota: Dimensiones en pulgadas • Note: All dimensions in inch

TRUNNION BALL VALVES (BOLTED BODY)

Lista de Partes para Válvulas de Cuerpo Atornillado
Trunnion bolted valve assembly list.

- 1 Cuerpo • Body
- 2 Conexion (Extremo) • End Connection
- 3 Bola • Ball
- 4 Caja de engranes • Gear box
- 5 Anillo del asiento • Seat ring
- 7 Asiento (inserto) • Seat (insert)
- 8 Inyector de sellante • Sealant injector
- 9 Vástago • Stem
- 10 Perno guía • Trunnion alignment pin
- 11 Roldana de apoyo • Thrust washer
- 12 Gasket • Gasket
- 13 Soporte muñon • Trunnion support
- 14 Gasket tapa secundaria • Secondary gasket
- 15 Gasket cuerpo • Body gasket
- 16 Gasket asiento • Seat gasket
- 17 Gasket asiento • Seat gasket
- 18 Tapa secundaria • Gand cap
- 19 Tapa primaria • Top Flange
- 20 Roldana de vástago inferior • Thrust bearing
- 21 Cojinete del soporte-muñon • Bearing
- 22 Seguidor de asiento • Seat follower
- 23 Tapón • Cover
- 24 Valvula de alivio • Relief valve
- 25 Resorte • Spring
- 26 Resorte (anti-estático) • Anti-static device
- 27 Conector (anti-estático) • Anti-static ball
- 28 O-ring tapa secundaria • Gand cap o-ring
- 29 O-ring tapa secundaria • Top flange o-ring
- 30 O-ring tapa porta asiento • Seat o-ring
- 31 O-ring cuerpo • Body o-ring
- 32 Tuerca cuerpo • Body nut
- 33 Birlo cuerpo • Body stud
- 34 Tornillo allen tapa primaria • Hex cap set screw
- 35 Tornillo allen tapa secundaria • Hex cap set screw
- 36 Tuerca caja de engranes • Gear box nut
- 37 Birlo caja de engranes • Gear box stud
- 38 Perno guía • Follower pin
- 39 Perno guía de cuña • Wedge follower pin
- 40 Cuña • Wedge
- 41 Placa de identificación • Id plate

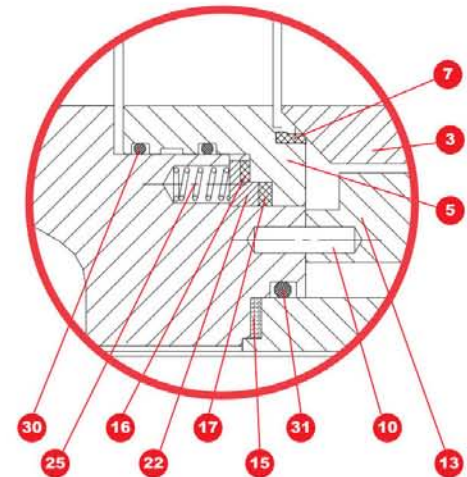
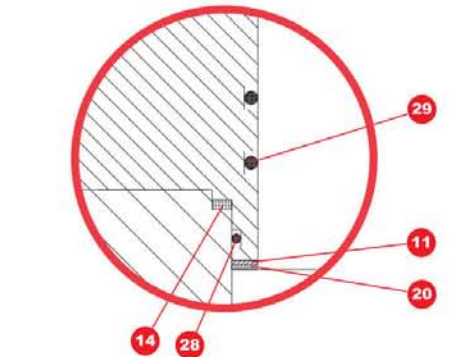
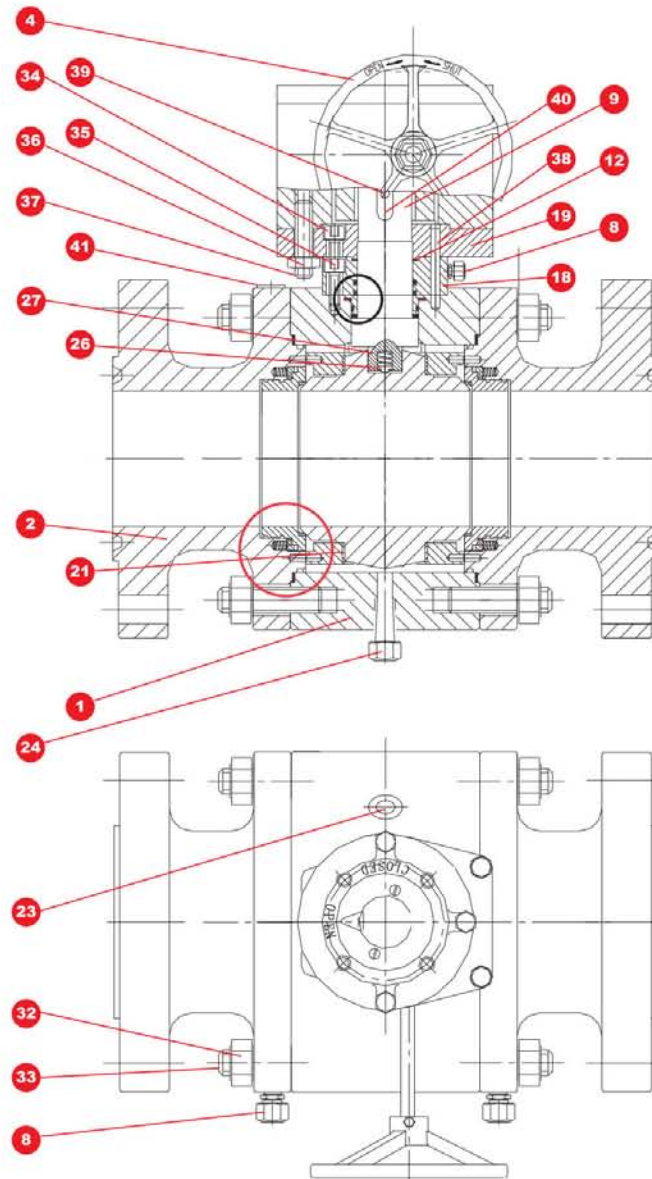

Válvula Forjada (Cuerpo atornillado ó Cuerpo Integral Soldado) *Forged Body Valves (Bolted or Welded Body)*

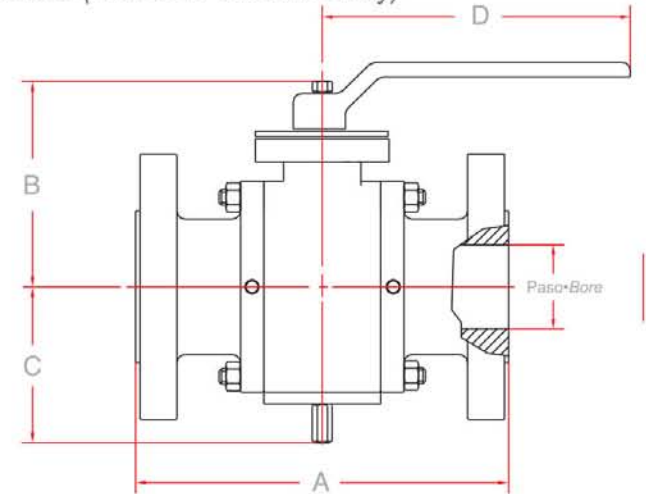
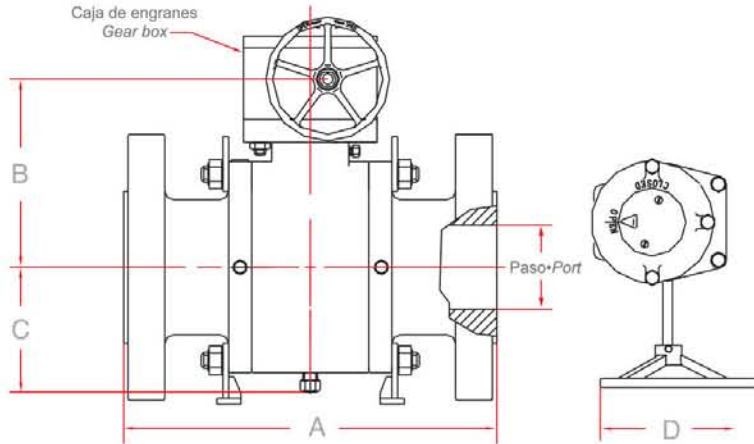

Dimensiones • Dimensions

Serie 84 (Clase 600) • Series 84 (Class 600)

Medida / Size	Paso / Bore mm	A (mm)	B (mm)	C (mm)	D (mm)	Peso / Weight kg
2	51	292	206	113	400	45
3	76	356	315	129	750	80
4	102	432	330	169	1000	150
6	152	559	345	148	*300	248
8	203	660	415	185	*300	438
10	254	787	427	226	*500	625
12	305	838	465	269	*600	701
14	337	889	519	300	*600	1230
16	387	991	638	350	*600	1535
18	438	1092	683	402	*600	2135
20	489	1194	748	446	*600	2640
22	540	1295	854	492	*800	3370
24	591	1397	917	531	*800	3960
28	686	1549	958	556	*800	6060
30	737	1651	1035	620	*800	6690
32	781	1778	1087	666	*800	7825
34	832	1930	1104	666	*800	8460
36	876	2083	1143	718	*800	10650
40	978	2337	1435	887	*800	14700
42	1022	2438	1638	923	*800	16410
48	1168	2845	1765	1068	*800	24200

* Válvula con caja de engranes • Valve with gear box

Serie 85 (Clase 900) • Series 85 (Class 900)

Medida / Size	Paso / Bore mm	A (mm)	B (mm)	C (mm)	D (mm)	Peso / Weight kg
2	51	368	217	119	460	52
3	76	381	327	133	1000	87
4	102	457	343	176	*300	160
6	152	610	358	153	*300	385
8	203	737	431	193	*400	560
10	254	838	443	235	*500	820
12	305	965	484	280	*600	1125
14	324	1029	540	312	*600	1610
16	375	1130	660	365	*600	2010
18	425	1219	700	414	*600	2810
20	473	1321	770	459	*600	3460
22	524	1422	880	507	*800	4410
24	572	1549	945	547	*800	5497
28	667	1753	987	573	*800	10202
30	714	1880	1066	638	*800	11442
32	762	2032	1120	686	*800	12102
34	810	2159	1137	688	*800	17462
36	857	2286	1177	739	*800	20154

En Clase 900, todos los insertos de los asientos son de Nylon.
In the class 900 all seat inserts are in nylon.

Nota: Dimensiones en pulgadas • Note: All dimensions in inch

TRUNNION BALL VALVES

Válvula Forjada (Cuerpo atornillado ó Cuerpo Integral Soldado)
Forged Body Valves (Bolted or Welded Body)

Serie 86 (Clase 1500) • *Series 86 (Class 1500)*

Medida / Size	Paso / Bore mm	A (mm)	B (mm)	C (mm)	D (mm)	Peso / Weight kg
2	51	368	221	130	750	60
3	76	470	297	152	* 300	115
4	102	546	345	166	* 300	194
6	146	705	365	192	* 400	580
8	194	832	423	238	* 500	752
10	250	991	560	274	* 600	1195
12	289	1130	608	318	* 600	2170
14	318	1257	662	483	* 600	2250
16	362	1384	796	534	* 600	2760
18	406	1537	849	606	* 600	3646
20	451	1664	964	686	* 800	4497
22	495	1816	1025	731	* 800	5731
24	533	2045	1065	775	* 800	7151

* Válvula con caja de engranes • *Valve with gear box*

Nota: Dimensiones en pulgadas • *Note: All dimensions in inch*

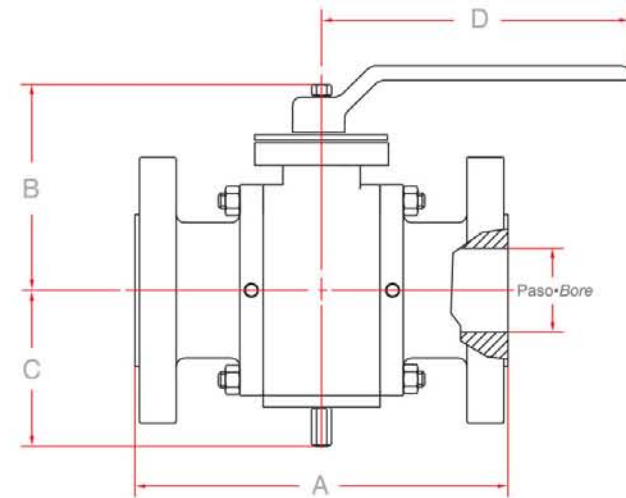

Dimensiones • *Dimensions*

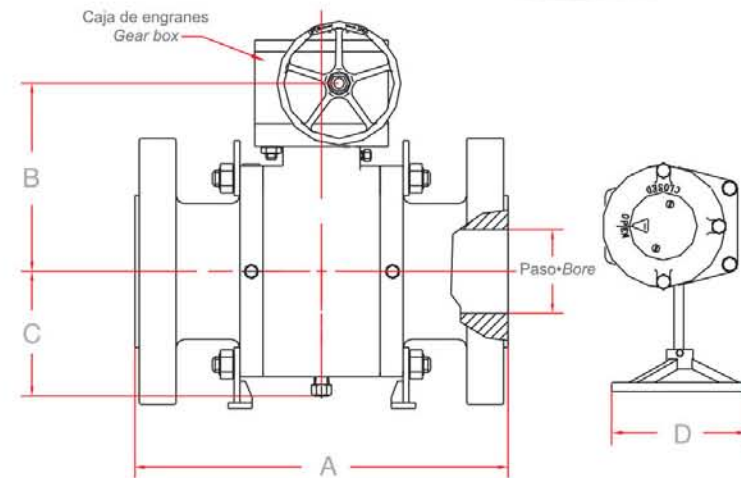

TRUNNION BALL VALVES (WELDED BODY)

- 1 Cuerpo • *Body*
- 2 Conexión (Extremo) • *End Connection*
- 3 Bola • *Ball*
- 4 Anillo del asiento • *Seat ring*
- 5 Asiento (inserto) • *Seat (insert)*
- 6 Asiento de bola • *Ball seat*
- 7 Vástago • *Stem*
- 8 Perno guía • *Trunnion alignment pin*
- 9 Roldana de apoyo • *Thrust washer*
- 10 Soporte muñon • *Trunnion support*
- 11 Gasket tapa secundaria • *Secondary gasket*
- 12 Gasket asiento • *Seat gasket*
- 13 Gasket • *Gasket*
- 14 Gasket asiento • *Seat gasket*
- 15 Tapa secundaria • *Gand cap*
- 16 Tapa primaria • *Top Flange*
- 17 Roldana • *Washer*
- 18 Cojinete del soporte-muñon • *Bearing*
- 19 Seguidor de asiento • *Seat follower*
- 20 Valvula de alivio • *Relief valve*
- 21 Valvula de alivio • *Relief valve*
- 22 Resorte • *Spring*
- 23 Conector (anti-estático) • *Anti-static ball*
- 24 Resorte (anti-estático) • *Anti-static device*
- 25 O-ring tapa secundaria • *Gand cap o-ring*
- 26 O-ring tapa secundaria • *Top flange o-ring*
- 27 O-ring tapa porta asiento • *Seat o-ring*
- 28 Gasket asiento • *Seat gasket*
- 29 Tornillo allen tapa secundaria • *Hex cap set screw*
- 30 Tornillo allen tapa primaria • *Hex cap set screw*
- 31 Birlo caja de engranes • *Gear box stud*
- 32 Tuerca caja de engranes • *Gear box nut*
- 33 Guía • *Pin*
- 34 Cuña • *Wedge*
- 35 Perno guía de cuña • *Wedge follower pin*
- 36 Caja de engranes • *Gear box*
- 37 Inyector de sellante • *Sealant injector*
- 38 Inyector de sellante • *Sealant injector*
- 39 Perno placa de identificación • *Id plate pin*
- 40 Placa de identificación • *Id plate*
- 41 Valvula de seguridad • *Check valve*
- 42 Cojinete de vástago • *Stem bearing*
- 43 O-ring tapa secundaria • *Top flange o-ring*

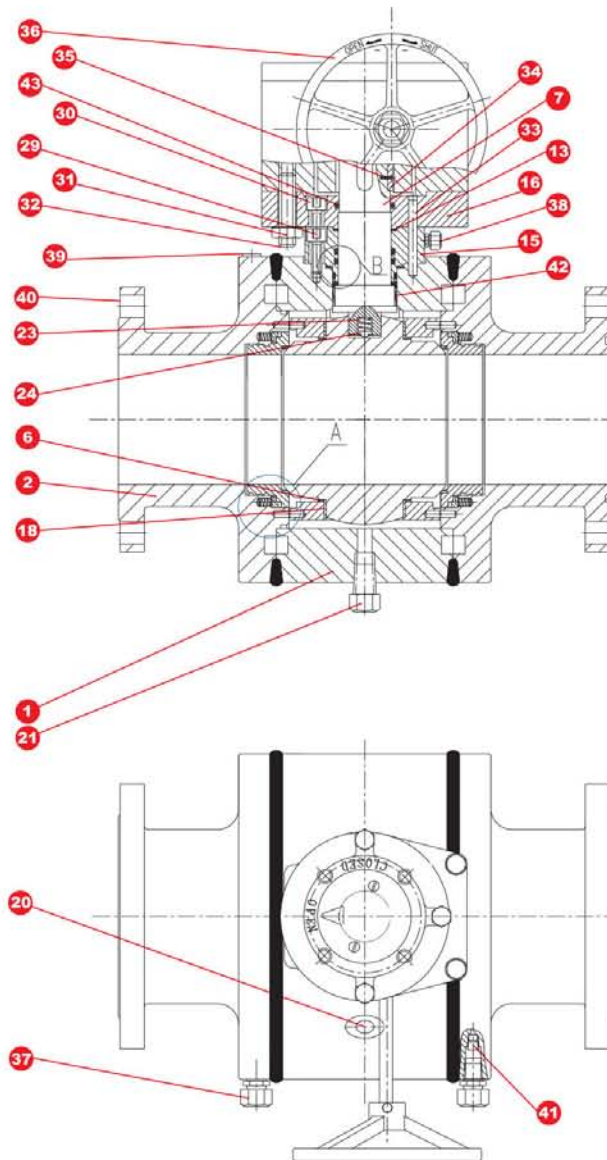

Lista de partes para válvulas de cuerpo integral Soldado
List of components for welded valves

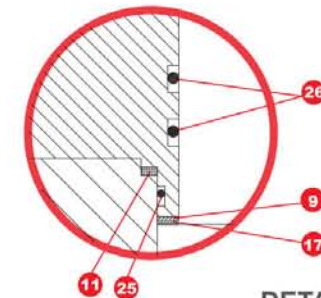

DETALLE A
DETAIL A

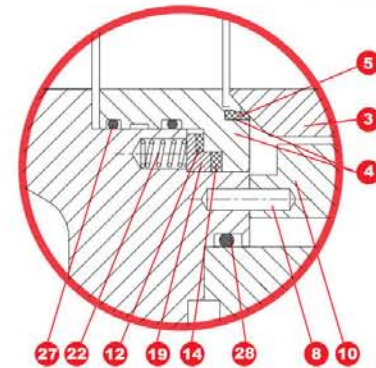

DETALLE B
DETAIL B

TRUNNION BALL VALVES (CAST BODY)

- 1 Cuerpo • *Body*
- 2 Conexión (Extremo) • *End Connection*
- 3 Bola • *Ball*
- 4 Caja de engranes • *Gear box*
- 5 Anillo del asiento • *Seat ring*
- 7 Asiento inserto • *Seat (insert)*
- 8 Inyector de sellante Vástago / Asiento
Steam / Seat Sealant injector
- 9 Vástago • *Stem*
- 10 Perno guía • *Trunnion alignment pin*
- 11 Roldana de apoyo • *Thrust washer*
- 12 Gasket • *Gasket*
- 13 Soporte muñon • *Trunnion support*
- 14 Gasket tapa secundaria • *Secondary gasket*
- 15 Gasket cuerpo • *Body gasket*
- 16 Gasket asiento • *Seat gasket*
- 17 Gasket asiento • *Seat gasket*
- 18 Tapa secundaria • *Gand cap*
- 19 Tapa primaria • *Top Flange*
- 20 Roldana de vástago inferior • *Thrust bearing*
- 21 Cojinete del soporte-muñon • *Bearing*
- 22 Seguidor de asiento • *Seat follower*
- 23 Tapón • *Cover*
- 24 Válvula de alivio • *Relief valve*
- 25 Resorte • *Spring*
- 26 Resorte (anti-estático) • *Anti-static device*
- 27 Conector (anti-estático) • *Anti-static ball*
- 28 O-ring tapa secundaria • *Gand cap o-ring*
- 29 O-ring tapa secundaria • *Top flange o-ring*
- 30 O-ring tapa porta asiento • *Seat o-ring*
- 31 O-ring cuerpo • *Body o-ring*
- 32 Tuerca cuerpo • *Body nut*
- 33 Birlo cuerpo • *Body stud*
- 34 Tornillo allen tapa primaria • *Hex cap set screw*
- 35 Tornillo allen tapa secundaria • *Hex cap set screw*
- 36 Tuerca caja de engranes • *Gear box nut*
- 37 Birlo caja de engranes • *Gear box stud*
- 38 Perno guía • *Follower pin*
- 39 Perno guía de cuña • *Wedge follower pin*
- 40 Cuña • *Wedge*
- 41 Placa de identificación • *Id plate*

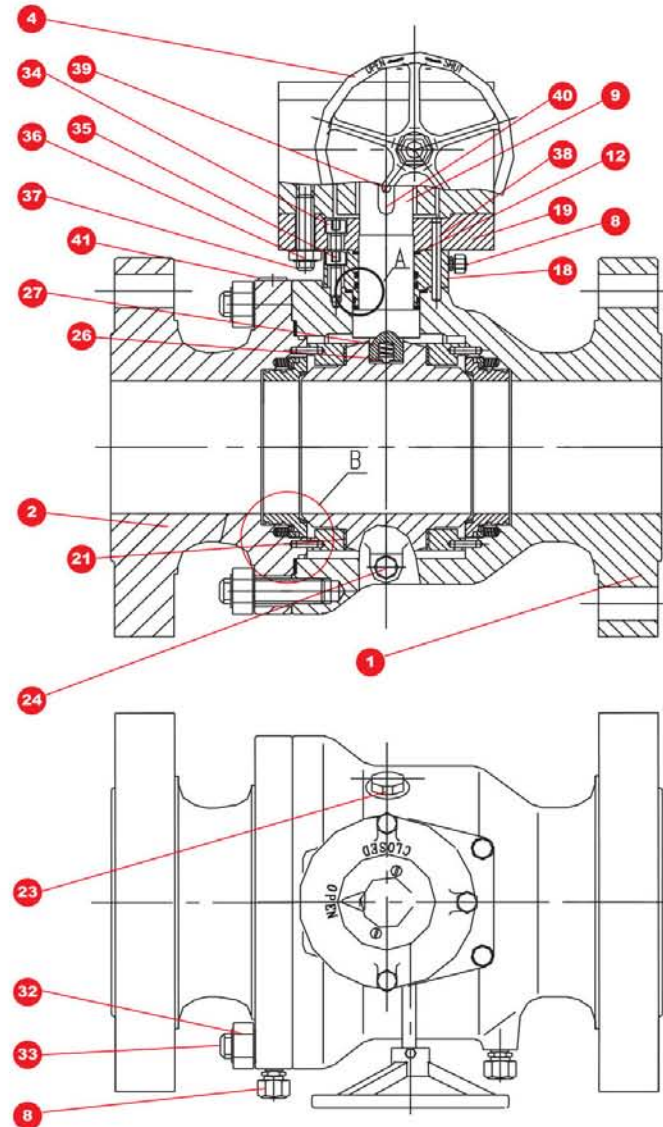

Lista de partes para válvulas fundidas
List of components for cast valves

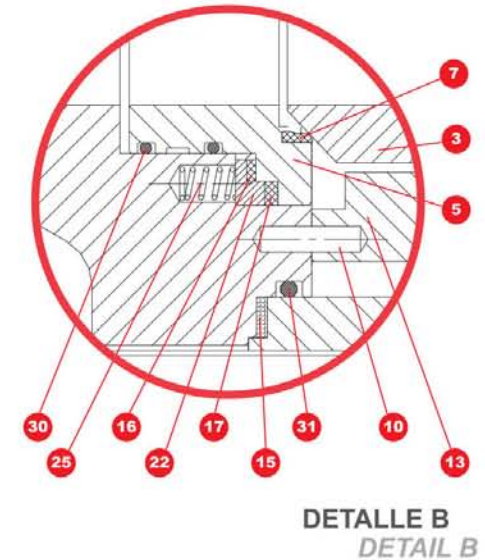
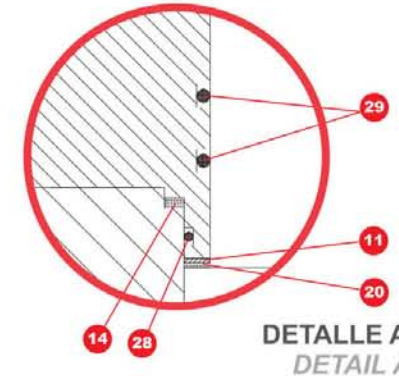

TRUNNION BALL VALVES

Válvula Fundidas (Cuerpo atornillado) Cast Valves (Bolted body)

Serie 82 (Clase 150) • Series 82 (Class 150)

Medida / Size	Paso / Bore mm	A (mm)	B (mm)	C (mm)	Peso / Weight kg
2	51	178	165	230	17
3	76	203	193	400	33
4	102	229	231	460	50
6	152	394	329	* 500	93
8	203	457	393	* 500	166
10	254	533	401	* 500	273
12	305	610	441	* 500	475
14	337	686	481	* 500	570
16	387	762	598	* 500	778
18	438	864	643	* 500	935
20	489	914	708	* 500	1190
22	540	1016	798	* 500	1346
24	591	1067	863	* 500	1579

* Válvula con caja de engranes • Valve with gear box

Serie 83 (Clase 300 PT) • Series 83 (Class 300)

Medida / Size	Paso / Bore mm	A (mm)	B (mm)	C (mm)	Peso / Weight kg
2	51	216	165	230	18
3	76	283	193	400	40
4	102	305	231	750	63
6	152	403	329	* 1000	150
8	203	502	393	* 1500	240
10	254	568	401	* 500	305
12	305	648	441	* 500	507
14	337	762	481	* 500	602
16	387	838	598	* 500	1000
18	438	914	643	* 500	1160
20	489	991	708	* 500	1320
22	540	1092	798	* 500	1540
24	591	1143	863	* 500	1874

* Válvula con caja de engranes • Valve with gear box

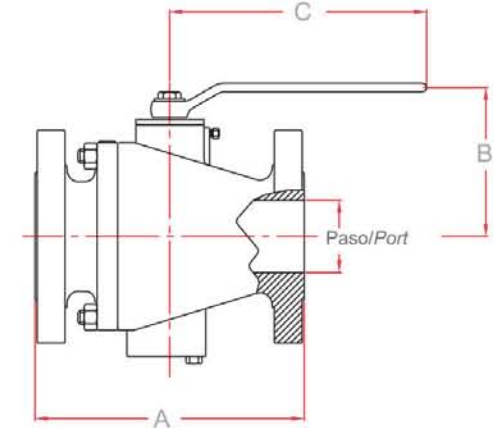

Dimensiones • Dimensions

Serie 84 (Clase 600) • Series 84 (Class 600)

Medida / Size	Paso / Bore mm	A (mm)	B (mm)	C (mm)	Peso / Weight kg
2	51	292	176	400	27
3	76	356	247	750	50
4	102	432	276	1000	80
6	152	559	363	* 500	220
8	203	660	363	* 500	350
10	254	787	426	* 500	600
12	305	838	548	* 500	820

* Válvula con caja de engranes • Valve with gear box

Serie 85 (Clase 900) • Series 85 (Class 900)

Medida / Size	Paso / Bore mm	A (mm)	B (mm)	C (mm)	Peso / Weight kg
2	51	368	192	460	52
3	76	381	279	1000	97
4	102	457	315	* 500	138
6	152	610	323	* 500	288
8	203	737	381	* 500	448
10	254	838	518	* 500	748
12	305	965	568	* 500	1018

* Válvula con caja de engranes • Valve with gear box

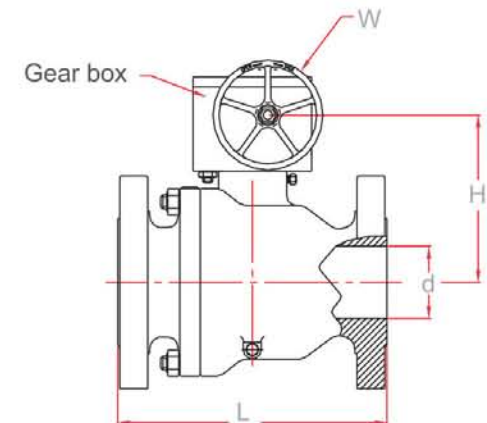

Nota: Dimensiones en pulgadas • Note: All dimensions in inch

STEAM TRAP



Materiales del cuerpo y tapón
Body Material and Pipe End

Cuerpo: AISI 420F • *Body: AISI 420F*
Disco: AISI 420 • *Disk: AISI 420*
Tuerca: AISI 416 • *Nut: AISI 416*

Placa de identificación:

Acero inoxidable 304

Tag Plate: *Stainless Steel 304*

Lista de partes

List of components

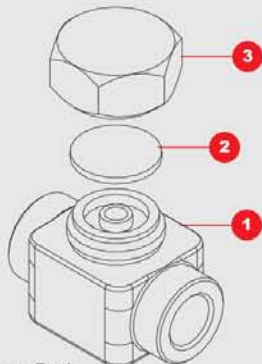

- 1 Cuerpo • *Body*
- 2 Disco trampa vapor • *Steam trap disc*
- 3 Tuerca tapa • *End cap*

Trampa de vapor del tipo termodinámica para uso rudo, unidireccional (disco flotante, conexión roscada NPT, lapeado y templado de disco y asiento), fácil mantenimiento.

Aplicaciones: Como purga de las líneas de distribución y purga en intercambiadores de calor.

Instalación: Trabaja perfectamente en cualquier posición, para sistemas de vapor es recomendable su instalación horizontal; mientras que en sistemas de aire comprimido es recomendable su instalación vertical (flujo descendente).

Thermodynamic steam trap for rough use, unidirectional (floating disk, threaded connection NPT, polished and quenched), easy maintenance.

Applications: Can be used as a draining in the distribution line and/ or of the heat exchanger applications.

Installation: The steam trap works perfectly in any position: for steam systems it is recommended to install it horizontally, while for compression air systems a vertical installation is recommended (descending flow).

Capacidad de descarga a temperatura de vapor saturado (Kg/hr)
Discharge capacity at the temperature of saturated steam (Kg/hr)

Condiciones de Operación y de Diseño <i>Operation and Design conditions</i>		
Presión máxima de operación <i>Maximum Operation Pressure</i>	604 PSI	42 Kg/cm ²
Presión máxima admisible <i>Maximum Admissible Operation</i>	914 PSI	64 Kg/cm ²
Temperatura máxima admisible <i>Maximum Admissible Temperature</i>	752°F	400°C

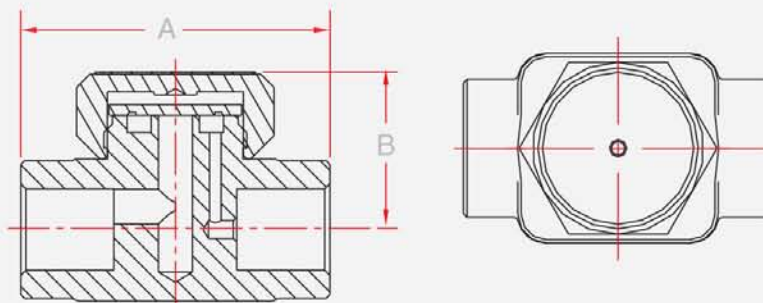
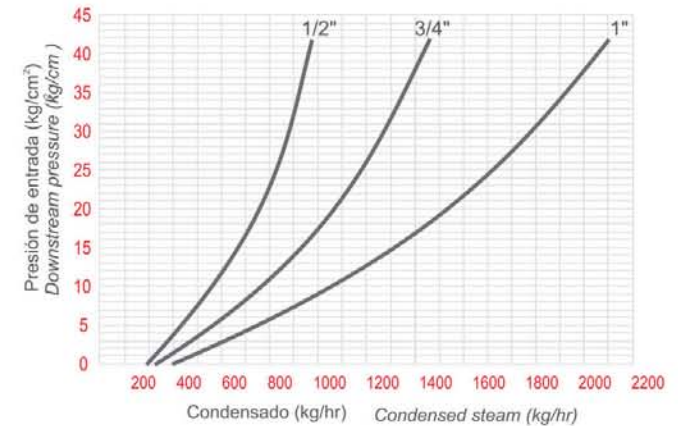

Trampa de vapor • *Steam trap*

Medida / Size	A	B
1/2	2.70	1.34
3/4	2.75	1.52
1	3.30	1.95

Nota: Dimensiones en pulgadas
Note: All dimensions in inch

3000 lbs Ends



Codos 90° con rosca NPT en ambos extremos

Elbow, 90°, threaded connection NPT on both sides

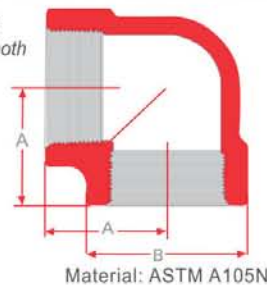

Material: ASTM A105N

CODOS 45° NPT DE 1/4" a 2" / 90° Elbow from 1/4" to 2"				
Tamaño Normal	A (in)	B (in)	Cuerda	Peso (Kg)
1/4"	.969	1.031	1/4"-18 NPT	0.148
3/8"	1.125	1.313	3/8"-18 NPT	0.299
1/2"	1.313	1.500	1/2"-14 NPT	0.425
3/4"	1.500	1.813	3/4"-14 NPT	0.750
1"	1.750	2.188	1"-11 1/2 NPT	1.202
1 1/4"	2.000	2.438	1 1/4"-11 1/2 NPT	1.344
1 1/2"	2.375	2.969	1 1/2"-11 1/2 NPT	2.381
2"	2.500	3.313	2"-11 1/2 NPT	3.012

Conexión 3000 lb, construcción en acero al carbón forjado ASTM A-105 cumple con NACE MR 0175, disponible en medidas de 1/4" a 2" para codo de 90°, "T" recta y tuerca unión en conexiones roscadas NPT y SW, en medidas de 1/2" a 2" para codo de 45°.

Connection 3000 lb, forged carbon steel ASTM A-105, in accordance with NACE MR 0175, available from 1/4" to 2" in 90° elbow, T and union nut for threaded connections NPT and SW. In 45° it is available from 1/2" to 2".

Elbow, 90°, weldable connections Codos 90° con extremos Soldables

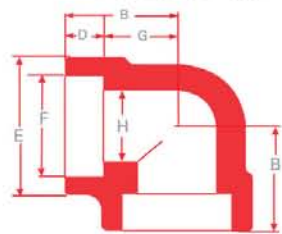

Material: ASTM A105N

CODOS 45° NPT DE 1/4" a 2" SW / 90° Elbow from 1/4" to 2"							
Tamaño Normal	B (in)	D (in)	E (in)	F (in)	G (in)	H (in)	Peso (Kg)
1/4"	.813	.375	.8751	.555	.438	.364	0.096
3/8"	.969	.438	.031	.6900	.531	.493	0.124
1/2"	1.125	.500	1.313	.855	.625	.622	0.240
3/4"	1.313	.563	1.500	1.065	.750	.824	0.391
1"	1.500	.625	1.813	1.330	.875	1.049	0.506
1 1/4"	1.750	.688	2.188	1.675	1.063	1.380	0.833
1 1/2"	2.000	.750	2.438	1.915	1.250	1.610	1.114
2"	2.375	.875	2.969	2.406	1.500	2.067	1.565



Codos 45° con rosca NPT en ambos extremos

Elbow, 45°, threaded connection NPT on both sides

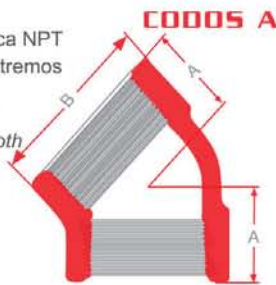

Material: ASTM A105N

Elbow 45° weldable connections

CODOS 45° NPT DE 1/4" a 2" / 45° Elbow from 1/4" to 2"				
Tamaño Normal	A (in)	B (in)	Cuerda	Peso (Kg)
1/4"	.356	1.031	1/4"-18 NPT	0.182
3/8"	.542	1.313	3/8"-18 NPT	0.272
1/2"	.873	1.500	1/2"-14 NPT	0.356
3/4"	.926	1.813	3/4"-14 NPT	0.542
1"	1.750	2.188	1"-11 1/2 NPT	0.873
1 1/4"	2.000	2.438	1 1/4"-11 1/2 NPT	0.926
1 1/2"	2.375	2.969	1 1/2"-11 1/2 NPT	2.013
2"	2.500	3.313	2"-11 1/2 NPT	2.116

TECHNICAL DATA / FLOATING TRUNNION



Codos 45° con extremos Soldables

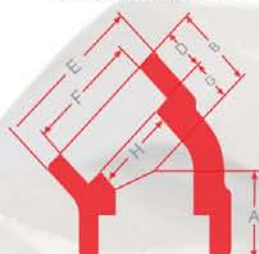

Material: ASTM A105N

CODOS 45° NPT DE 1/4" a 2" SW / 45° Elbow from 1/4" to 2"

Tamaño Normal	B (in)	D (in)	E (in)	F (in)	G (in)	H (in)	Peso (Kg)
1/4"	.688	.375	0.875	.555	.313	0.364	0.091
3/8"	.750	.438	1.031	.690	.313	0.493	0.136
1/2"	.875	.438	1.313	.855	.438	0.622	0.181
3/4"	1.000	.500	1.500	1.065	.500	0.824	0.227
1"	1.125	.563	1.813	1.330	.563	1.049	0.363
1 1/4"	1.313	.625	2.188	1.675	.688	1.380	0.499
1 1/2"	1.375	.563	2.438	1.915	.813	1.610	0.726
2"	1.688	.688	2.969	2.406	1.000	2.067	1.096

"T" con rosca NPT al centro y laterales de 1/4" a 2".

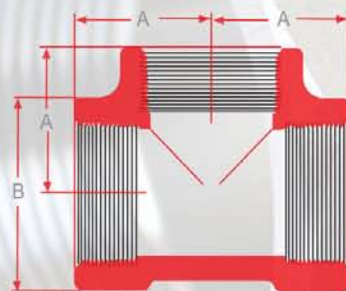

Material: ASTM A105N

"T" NPT de 1/4" a 2".

Tamaño Nominal	A (in)	B (in)	Cuerda	Peso (Kg)
1/4"	0.969	1.031	1/4"-18 NPT	0.213
3/8"	1.125	1.313	3/8"-18 NPT	0.412
1/2"	1.313	1.500	1/2"-14 NPT	0.573
3/4"	1.500	1.813	3/4"-14 NPT	0.919
1"	1.750	2.188	1"-11 1/2 NPT	1.445
1 1/4"	2.000	2.438	1 1/4"-11 1/2 NPT	1.178
1 1/2"	2.375	2.969	1 1/2"-11 1/2 NPT	3.096
2"	2.500	3.313	2"-11 1/2 NPT	3.293

"T" con extremos soldables de 1/4" a 2".

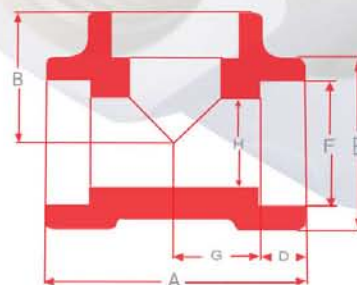

Material: ASTM A105N

"T" SW de 1/4" a 2".

Tamaño Nominal	A (in)	B (in)	D (in)	E (in)	F (in)	G (in)	H (in)	PESO (Kg)
1/4"	1.625	0.813	0.375	0.875	0.555	0.438	0.364	0.121
3/8"	1.938	0.969	0.438	1.031	0.690	0.531	0.493	0.168
1/2"	2.250	1.125	1.500	1.313	0.855	0.625	0.622	0.326
3/4"	2.625	1.313	1.563	1.500	1.065	0.750	0.824	0.419
1"	3.000	1.500	1.625	1.813	1.330	0.875	1.049	1.662
1 1/4"	3.500	1.750	1.688	2.188	1.675	1.063	1.380	1.002
1 1/2"	4.000	2.000	0.750	2.438	1.915	1.250	1.610	1.311
2"	4.750	2.375	0.875	2.969	2.406	1.500	2.067	2.113

TECHNICAL DATA / FLOATING & TRUNNION

CARACTERÍSTICAS ESPECIALES

Las Válvulas de bola marca Worcester /Rhino Valves WORLDWIDE con diseño de 3 piezas en medidas de 1/2" a 2" permiten una sencilla instalación y mantenimiento (al retirar 3 tornillos y destornillar el cuarto) en sistemas donde existe un fácil acceso a las líneas de trabajo. Este diseño permite usar la válvula como una tuerca unión, eliminando así conexiones extras.

SPECIAL CHARACTERISTICS

WORCESTER / RHINO VALVES WORLDWIDE brand, three-piece design in sizes from 1/2" to 2" allows simple installation and maintenance (removing three bolts and unscrewing the fourth) in areas wich can be accessed easily. Additionally, the design allows to use the valve like a union nut, avoiding extra connections.

SELLO DE CUERPO

El cuerpo y la tapa (ó tapón) de la Válvula están diseñados para formar una caja donde se alojan el sello de elastómero. El sello no es deformado de forma excesiva al entrar en contacto el cuerpo y la tapa.

BODY SEAL

The body and the pipe end (or Plug) of the valve are designed to form a box where the elastomer seal is placed. The seal is not deformed excessively since the body and the pipe end (or Plug) enter in contact.



ASIENTOS RESILENTES FLOTANTES

El diseño de las Válvulas de bola Flotante WORCESTER® / RHINO VALVES WORLDWIDE® en medidas de 1/2" a 10", permite que la presión del fluido en cualquier dirección se transmita a la bola flotante, el cual empuja el asiento secundario de apoyo, generando un sello hermético de alta presión. Los asientos elásticos con ranuras de alivio patentados por WORCESTER® / RHINO VALVES WORLDWIDE® permiten liberar la presión al asiento de entrada contra la bola, dando como resultado un bajo torque, larga vida y suave operación aun con presiones diferenciales altas. Además los asientos limpian a la bola de los materiales que se adhieren asegurando un mejor sellado.

Nota: Excepto válvulas criogénicas y aquellas equipadas con asientos integrales y "Cavity Filled"



Torque del lado de la Tuerca
Torque of the side of the nut

Diametro Tornillo	Acero al Carbon in-lb	Acero Inoxidable in-lb
1/4"	96-120	72-94
5/16"	156-204	120-144
3/8"	216-264	192-216
7/16"	480-540	336-384

FLOATING RESILIENT SEATS

The design of WORCESTER® / RHINO VALVES WORLDWIDE®'s Floating ball valves in sizes from 1/2" to 10" assures pressure transmission of the fluid from any direction to the floating ball. The ball will be pushed against the second support SEAT generating a hermetic seal at high pressures. The elastic seats with relief spots patented by WORCESTER® / RHINO VALVES WORLDWIDE® allow to relieve the pressure from the Downstream seat against the ball, leading to allow torque, a long life and a soft operation even at nightly varying pressures. Besides, the seats clean the ball from stick materials wich assures a better sealing.

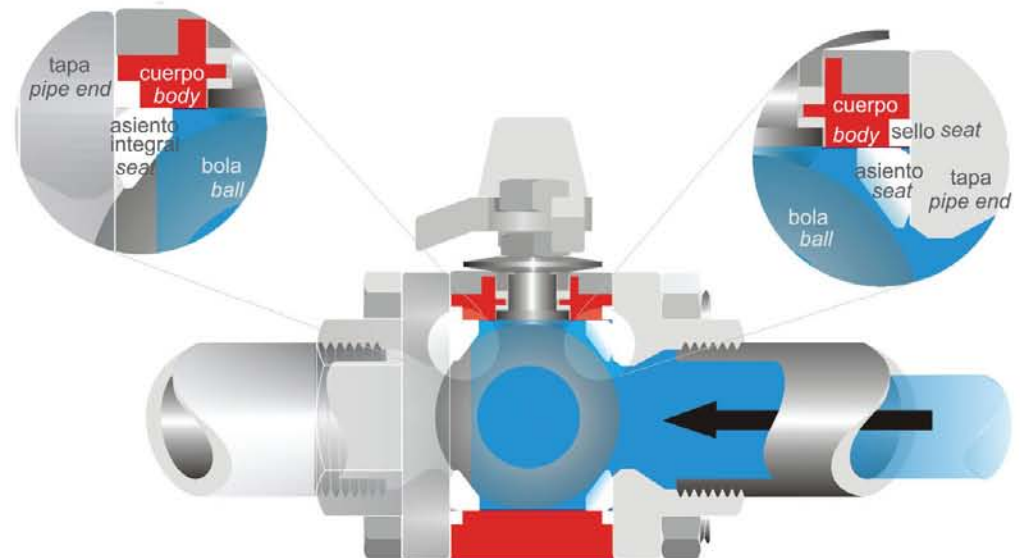

APLICACIONES

Esta simplicidad de instalación y mantenimiento hace ideal a la Válvula para una variedad de aplicaciones, Incluyendo la industria Química, Producción de Gas y Petróleo, Refinación y Transformación, Textiles, Pulpa y Papel, Farmacéutica, Alimentos y Bebidas, Tratamiento de aguas entre otras

APPLICATIONS

The Simplicity of installing and maintaining the valve makes it ideal for a variety of applications in the Chemicals industry, the production of Gas and Petroleum, Refinement and Transformation, Textiles, Pulp and Paper, Pharmaceutics, Food and Beverages, and Treatment of Water, among others.

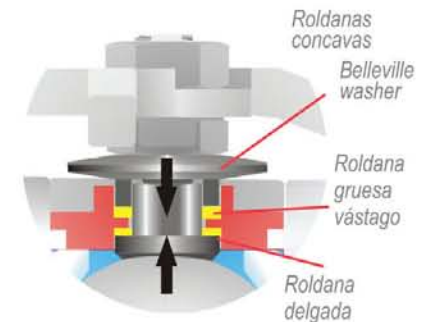

VASTAGO A PRUEBA DE EXPULSION

EL vástago auto ajustable en válvulas marca WORCESTER® / RHINO VALVES WORLDWIDE® en medidas de 1/2" a 10" ha sido diseñado a pruebas de expulsión por presurización en la válvula. Insertando desde el interior a través de la cavidad del cuerpo asegurando su posición en el interior. Un sello adicional en la parte superior del cuerpo es mantenimiento en su lugar por un separador, dos roldanas concavas y una tuerca de vástago, ésta última permite un rápido ajuste del sello en la línea. Las roldanas cóncavas responden a deformaciones mecánicas y térmicas proporcionando un ajuste automático para compensar la presión en el sello.

BLOW-OUT PROOF STEM

WORCESTER® / RHINO VALVES WORLDWIDE®'s self-adjusting stem in sizes from 1/2" a 10", has been design Blow-Out Prof. For along life without leakage (avoiding expulsión of the stem due to pressurization in the valve). The stem is inserted from the inside through the cavity of the body, which assures its correct position in the interior. An additional seal in the upper part of the body is maintained in its correct position by a separator, two Belleville washer, and a stem nut; the latter allows quick adjustment of the seal in the process line. The Belleville washers respond to mechanical and termal deformations providing an automatic adjustment in order to compensate the pressure in the seal.

DISPOSITIVO ANTI-ESTÁTICO

Las válvulas a prueba de fuego cuenta con vástago antiestático estándar cuando se manejan fluidos explosivos o inflamables, es inminente la presencia de cargas eléctricas acumuladas capaces de producir una chispa que puede provocar un accidente. Este dispositivo mantiene contacto permanente entre Cuerpo, Vástago y Bola, evitando que estos tengan cargas de diferente valor, debido a la fricción provocada al operar la válvula disipando en todo momento las cargas.

Nota: Para el manejo de todo tipo de fluidos inflamables se deben incluir vástago antiestático.

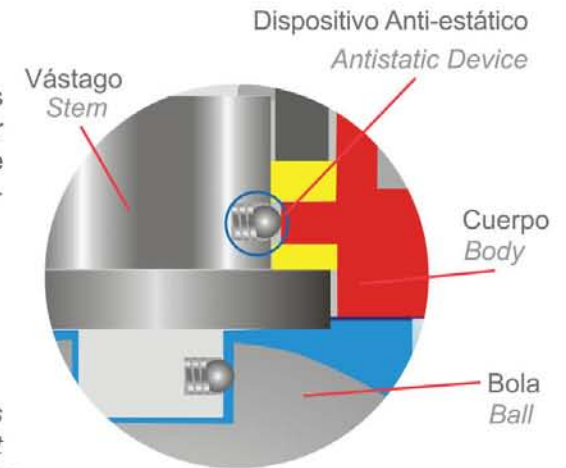

STEM WITH ANTISTATIC DEVICE

Fire-safe valves are provided with antistatic stem as standard. In some applications, when explosive or Flammable fluids are handle, electric charges producing Sparks are imminent which, in turn, can induce accidents. The antistatic device maintains permanente contact between body, stem, and ball all time avoiding electric charges caused by friction while operating the valve.

Note: For handling all kinds of flammable fluid san antistatic stem is required.

MANERAL

El maneral siempre indica la posición de la válvula para evitar errores en la posición de esta. En las Válvulas en medidas mayores a 2 1/2" no incluye maneral tipo palanca, ya que el torque de la válvula inrementa. En su lugar, se propoporciona un maneral corto para ser accionado con un tubo.

HANDLE

The handle always indicates the position of the valve to avoid errors in its operation. In valves bigger than 2 1/2", a fixed handle is not included because the length of this might cause the accidental operation. In its Place, a short handle is provided to be worked with a tube.

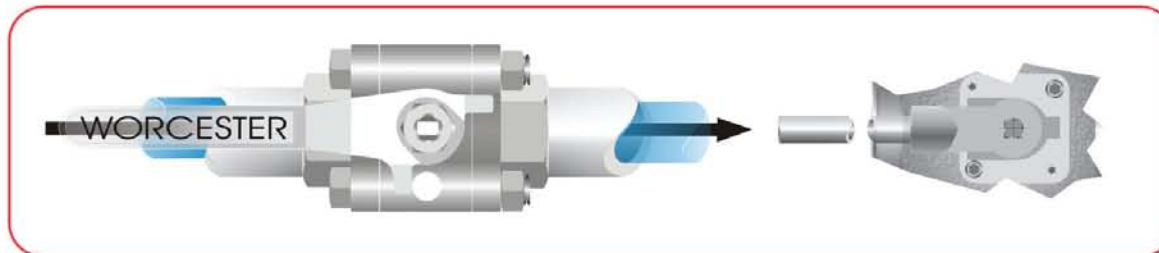

TORQUE: Fuerza requerida para cambiar la posición (Abierto- Cerrado) de una Válvula.

PLATO ISO

Disponible como opción en algunas válvulas y estandar en otras, este plato para Automatización cumple con las dimensiones establecidas en la norma ISO 5211, lo que hace la válvula compatible con elementos de automatización.

ISO MOUNTING PLATE

It's available in some of the valves as an option, and it is standard in others. This Plate fullfills the dimensions established in the ISO 5211 standard of automation, which makes to the valve compatible with the same specification's elements.

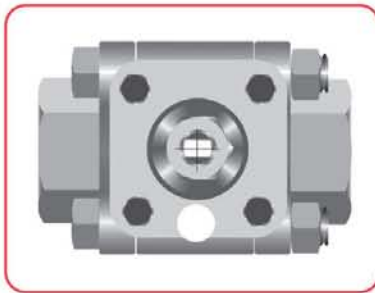

SPHERE OF RELIEF

The design of WORCESTER® / RHINO VALVES WORLDWIDE®'s cryogenic (all Models) ball valves assures that the relief hole of the ball (Which needs to be placed in the downstream direction) avoids an increase of pressure caused by the flash due to the concentration of fluids in the interior. This assures that the valve will not be pressurized during its maintenance.

ESFERAS DE ALIVIO

El diseño de la válvula marca WORCESTER® / RHINO VALVES WORLDWIDE® de las series criogénicas en todos sus modelos permite que el barreno de alivio de la bola (el cual debe colocarse en dirección de entrada del fluido) evite un incremento de presión debido al flasheo generado por concentración de fluido en su interior, esto asegura que la válvula no se presurice para su mantenimiento.

Nota: las esferas de alivio también son recomendadas en procesos en donde existan cambios de fases constantes, convirtiéndola en una válvula unidireccional.



ASIENTOS INTEGRALES

Cuando se requiera que la válvula selle en ambos lados, estos asientos son ideales, ya que además de no contar con ranuras de alivio, no se desplazan. Manteniendo contacto con la bola en todo momento y evitando la entrada de fluido al interior de la válvula en posición cerrada.

Son útiles para vacíos en tres vías y para convertir las válvulas uni-direccionales en bi-direccionales.

INTEGRAL SEATS

If it is required that the valve seals on both sides, these seats are ideal because they do not move from their correct position although they are not provided with relief slots; all the time they maintain contact with the ball and avoid that the fluid reaches the interior of the valve while the latter is closed. They are useful for vacuum and three-way services and converting a unidirectional in a bidirectional valve.

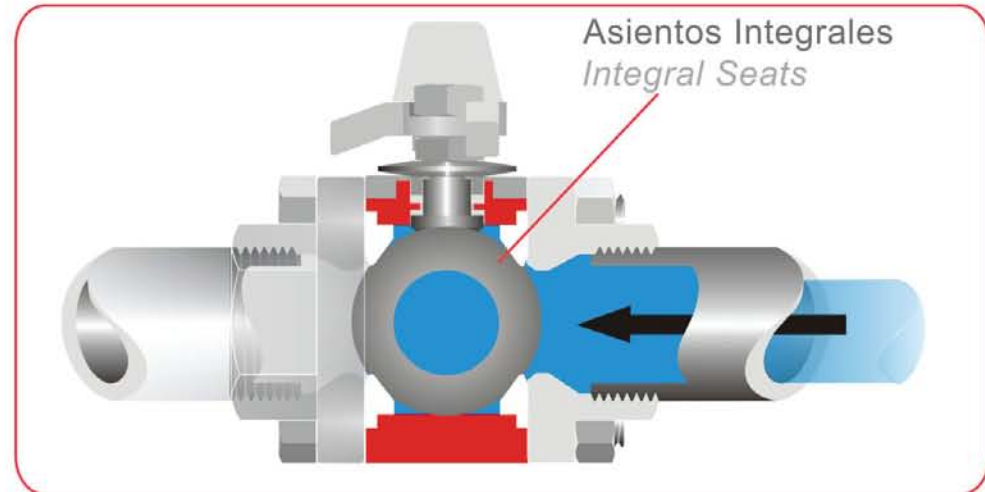
**ASIENTOS CAVITY FILLED**

Son excelentes en medios donde es importante evitar el contacto del fluido, en el interior del cuerpo, ya que por propio diseño el asiento cavity filled envuelve por completo a la bola evitando la acumulación del fluido hacia la cavidad del cuerpo.

CAVITY FILLED SEATS

These seats are very useful where it is important to avoid contact with the fluid in the interior of the body; the cavity filled seats wraps it self completely around the ball and avoids the accumulation of the fluid towards the cavity of the body.

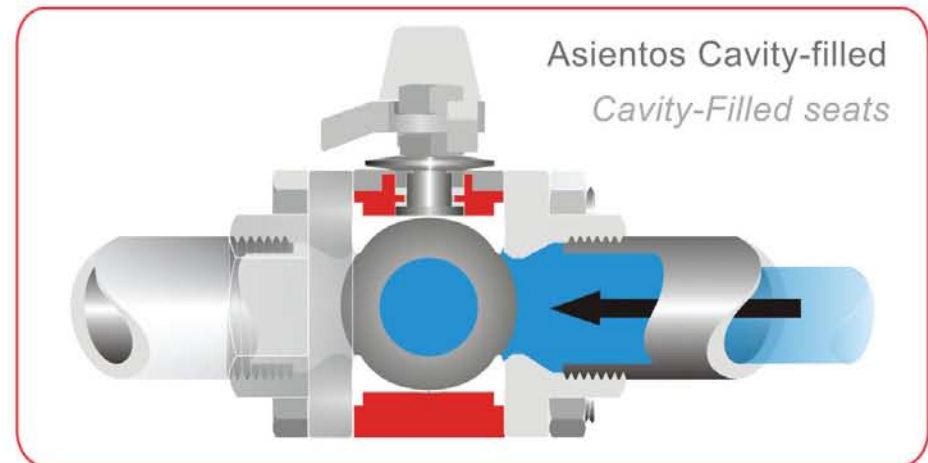

DATOS TECNICOS (Materiales de Asientos)

La siguiente información de aplicación deberá ser usada en conjunto con la gráfica de Presión vs. Temperatura y la tabla de corrosión.

B-BUNA. (También conocido como nitrilo) está especificado para trabajar a 300 psi en un rango de temperatura -30°C a 80°C. Es excelente para aplicaciones de derivados del petróleo. El material es IPC No. W-29-1. Su color es negro y puede tener un punto rojo.

T-PTFE. Hechos de PTFE virgen están especificados para trabajar a 1000 psi en un rango de temperatura de -45°C a 204°C. Es el material de sellado más común y uso con casi cualquier fluido. No es adecuado para ciclos térmicos amplios. Tiene una resistencia química excelente y de color blanco.

R-PTFE. Especificado para trabajar a 1500 psi en un rango de temperatura -45°C a 230°C. Estos asientos están hechos de PTFE reforzado con fibra de vidrio. Son más duros que los asientos de teflón virgen y tienen un mayor rango de presión de operación. Su resistencia química es igual que la del PTFE virgen (excepto para cáusticos fuertes calientes) Normalmente son suministrados en color azul para diferenciarlos.

M-MULTIFIL. Hecho en PTFE virgen con carga de fibra de vidrio, carbon y grafito, el multifil es adecuado para una operación a 1500 psi en un rango de temperatura -156°C a 260°C. También tiene un ciclo de vida más amplio que otros materiales. Los asientos son de color pardo.

Y-DELRHIN (LUBETAL). Es un material de asiento para alta presión. Especificados para trabajar hasta 6000 psi dependiendo del tamaño de la válvula y serie en un rango de temperatura -55°C a 82°C. Este material no debiera ser usado en servicio de oxígeno. Son hechas de "DuPont Acetal Homopolymer" y reforzado con teflón y fibra de vidrio. Son de color Hueso.

U-UHMWPE. (Ultra High Molecular Weight Polyethylene). Especificados para trabajar a 1500 psi en un rango de temperatura -55°C a 90°C. Su material es el Hércules UMW 1900 o similar. Puede ser usado en servicios de radiaciones bajas o medias y en aplicaciones en donde los fluorocarbonos no son tolerados. Son muy buenos en resistencia a la abrasión. Su color es hueso translúcido.

P-PEEK. (Poly Ether Ketone). Tiene muy buena capacidad para trabajar en alta presión y temperatura, su rango de operación es de 6000 psi rango de temperatura -55°C a 315°C. Tiene una excelente resistencia a la abrasión y es químicamente resistente a la mayoría de los fluidos excepto los sulfúricos y ácidos altamente oxidantes y halones. Es de color negro y notablemente más pesado que el multifil.

I-INOX. Hechos de resinas de PTFE virgen y acero inoxidable. Estos asientos tienen una muy buena capacidad para trabajar en alta presión y temperatura, su rango de operación es de 3000 psi y su rango de temperatura -196°C a 350°C. Es un excelente material para asientos en aplicaciones de vapor y fluido térmico (aceite caliente) y es un buen material para aplicaciones criogénicas. También tiene un mejor ciclo de vida que otros materiales. Son recomendables en resistencia a la abrasión. Su uso de vapor de presión de vapor esta garantizado hasta 150 psi.

D-DEVLON "V". API Grade. Este material esta entre los termoplásticos más fuertes y resistentes a la abrasión. Producidos por la fundición de monómeros es recomendado para aplicaciones de hasta 6250 psi y hasta 200°C.

TECHNICAL DATA (Seat materials)

The Following information for applications should be used together with the Pressure vs. Temperature rating and corrosion chart.

B-BUNA. (also Known as Nitrile), it is specified to work at 300 psi from -22°F a 176°F. It is excellent for petroleum products. The material is IPC No. W-29-1, Black in color, and may have one red dot.

T-PTFE. Made of PTFE virgin, it is specified to work at 1000 psi from -49°F a 399°F. It is the most common sealing material and is excellent for almost all fluids. PTFE has excellent Chemical resistance and is White in color.

R-PTFE. It is specified to work at 1500 psi from -49°F a 446°F. These seats are made from glass and reinforced PTFE. These seats are harder than virgin PTFE and have higher pressure-temperature ratings. Chemical resistance is the same as virgin Teflon (except for hot Strong caustics). These seats come in blue in order to distinguish them.

M-MULTIFIL. Made of PTFE filled with glass, carbon and graphite, it is specified to work at 1500 psi from -248°F a 500°F. It also has larger life cycle than other materials. These seats are grayish brown color.

Y-DELRHIN (LUBETAL). It is a material for high pressures, specified to work up to 6000 psi. The temperature range is from -67°F to 180°F. This material should not be used for oxygen services. It is made of "DuPont Acetal Homopolymer" and filled with PTFE and glass fiber. Its color is "bone-white".

U-UHMWPE. (Ultra High Molecular Weight Polyethylene) It is specified to work at 1500 psi from -67°F a 194°F. The material is Hercules UMW 1900 or similar. It can be used for low to medium radiation services and in application where fluorocarbons can not be tolerated. Good in abrasión resistance. Its color is "bone-white" translucent.

P-PEEK. (Poly Ether Ketone), It has good capacity for working at high pressures and temperature, specified to work at 6000 psi from -67°F a 599°F. It has an excellent resistance to abrasion and it is chemically resistant to most of the fluids except for sulfuric ones and highly oxidizing acids and halons. Its color is Black.

I-INOX. Made of virgin PTFE and stainless steel resin. These seats have very good capacity for working at high pressures and temperatures. It is specified to work at 3000 psi from -320°F to 662°F. It is an excellent material for seats in steam applications and termal fluids (hot oil) and it is a good material for difficult applications. It also has a larger life cycle than other materials and a very good resistance to abrasion.

D-DEVLON "V". API Grade. This material is one of the strongest and most resistant to abrasion termoplastic. It is manufactured by casting monomer and recommended for applications up to 6250 psi and up to 392 °F.

MATERIALES DE SELLOS

B-BUNA. Son buenos en servicios de alta presión. Su rango de operación es de -240°C a 120°C. Este material es el mejor elastómero para aplicaciones de derivados del Petróleo. Es muy usado junto con los asientos de DELRHIN en aplicaciones de alta presión. El material es Presición 7657 o equivalente. Su color es negro.

V-VITON. (Fluorocarbon Rubber). Estos sellos son excelentes en todo el rango de presión con un rango de temperatura de -30°C a 205°C. Vitón el el mejor elastómero para aplicaciones de alta temperatura más no en vapor. Están hechos de material 16209 o equivalente.

T-PTFE. Son excelentes sellos a presiones debajo de 1500 psi en un rango de temperatura de -30°C a 205°C. No es recomendable para ciclos térmicos mayores a 90° y no son reusables. Son de color blanco.

U-UHMWPE. (Ultra High Molecular Weight Polythylene) con un rango de temperatura de -55°C a 90°C. Su material es el Hércules UMW 1900 o similar. Puede ser usado en servicios de radiaciones bajas o medias y en aplicaciones en donde los fluorocarbonos no son tolerados. Son muy buenos en resistencia a la abrasión. Su color es hueso translúcido.

G-GRAFOIL. Empaque hecho de cinta de grafito su rango de temperatura es de -55°C a 535°C. Excepto en uso criogénico. Es el material usado como sello de cuerpo y vástago en todas las válvulas a prueba de fuego. Es color gris metálico.

WORCESTER® / RHINO VALVES WORLDWIDE® Tambien contamos con Kits de reparación para válvulas de bola.

SEAL MATERIALS

B-BUNA. These seals have good performance on high pressure service. Operational temperature range is -400°F to 248°F. This material is the best elastomer for petroleum service. It is used in high pressure applications as well as DELRHIN seats. The material is Presicion 7657 or similar and comes in black color.

V-VITON. (Fluorocarbon Rubber). These seals are excellent at all rated pressures with a range of -22°F to 401°F. Viton is the best elastomer for high temperature applications, but it should not be used for steam. They are made from presicion 16209 material or equivalent.

T-PTFE. Are excellent seals for pressures below 1500 psi at temperatures from -20°F to 400°F. It is not recommended to use them for thermal cycles higher than 194°F. They are not reusable and come in white color.

U-UHMWPE. (Ultra Molecular High Weight Polythylene) It is specified to work from -67°F to 194°F. It is made from Hercules UMW 1900 material or similar. It can be used in low radiation services and in applications where fluorocarbon are no tolerated. They are very good in resistance to abrasion. Its color is "bone-white" translucent.

G-GRAFOIL. Packing made of graphite tape. Its range of operating temperature is from -67°F to 995°F. in almost all fluids. This material is used for body and stem seals on all the WORCESTER® / RHINO VALVES WORLDWIDE® type "Fire safe". It comes in metallic gray.

WORCESTER® / RHINO VALVES WORLDWIDE® we also have repair kits available for ball valves.

Servicio de vapor para Válvulas de bola / Steam service for ball valves

Asiento Seat	Sello del cuerpo Body Seal	Rango para servicio on/off On/off range service	Caída de presión permisible para servicio de control Seat rating allowable throttling drop
M MULTIFIL	M MULTIFIL	250 psi WSP	150 psi (ΔP=50psi)
I -INOXIDABLE	M MULTIFIL	250 psi WSP	150 psi (ΔP=50psi)

Curvas de operación de asientos y sellos para líquido y gas (no aplica en vapor)
Curves of seat and seal operating conditions for liquid and gas (not applicable for steam)

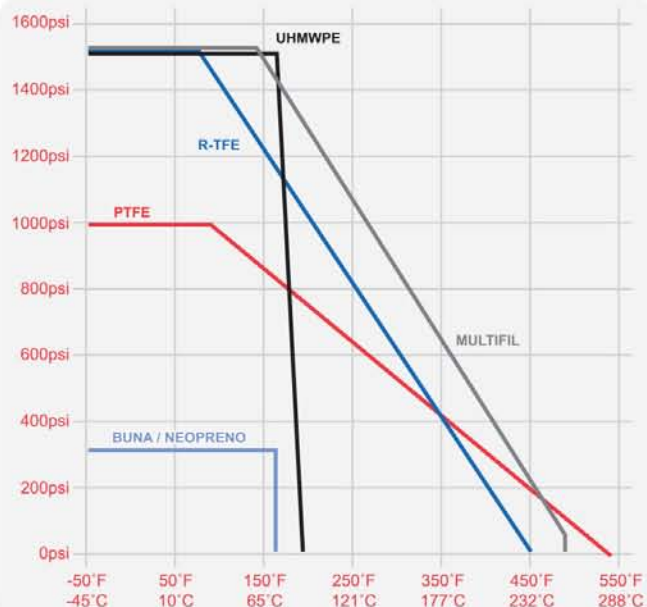
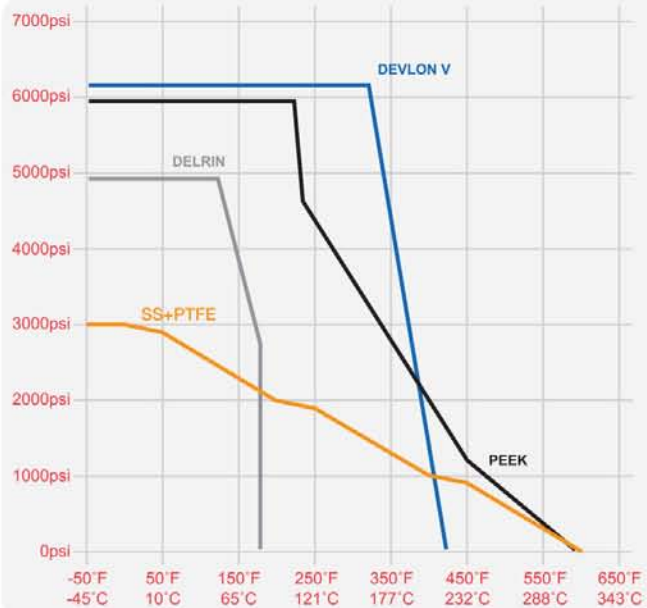

Importante: Antes de considerar el torque para el cálculo del actuador se debe tomar en cuenta el tipo de fluido a ser utilizado, ya que algunas sustancias no ayudan a la lubricación interna de la válvula incrementado el torque de ésta hasta un 40%. Esto sucede principalmente con los solventes, por lo que se debe considerar el factor de seguridad abajo indicado.

Important: Before considering the torque for the calculation of the actuator, the fluid which will be used should be taken into account; some substances do not provide internal lubrication to the valve and increase the torque up to 40%. This mainly happens with solvent substances, and therefore the below-mentioned security factor should be taken into account.

Paso Total

Las gráficas muestran el torque de las válvulas de paso nominal. El torque para una válvula de paso total es igual al torque de la válvula de paso nominal de diámetro inmediato superior. Ver siguiente tabla:

Full Port

Charts show torque values on nominal port, for full port torque value use equal nominal torque one size higher as below table:

Determinación del Torque	
Fluido	Factor
Aceite lubricantes (21-77°C)	0.8
Líquido libre de partículas	1.0
Lechadas, aguas sin tratar	1.8
Vapor saturado	1.0
Vapor sobrecalentado	1.3
Gas natural	1.5
Cloro	1.5

Determination of the Torque	
Fluid	Factor
Oils, lubrication media (70°F-350°F)	0.8
Clean liquid (particle free)	1.0
Dirty liquid (slurry), raw wather	1.8
Clean and wet gas (sat, steam)	1.0
Dry gas (superheated steam)	1.3
Dirty gas (natural gas)	1.5
Cholorine	1.5

Paso total Full port	Paso nominal Nominal port
1/4", 3/8"	1/2"
1/2"	3/4"
3/4"	1"
1"	1 1/4"
1 1/4"	1 1/2"
1 1/2"	2"
2"	2 1/2"

Curvas de torque paso nominal y paso total (Válvulas de bola Flotante)
 Curves of torque for nominal and full (Floating ball valves)

Nota: No está incluido el factor de seguridad / Note: the security factor is not included

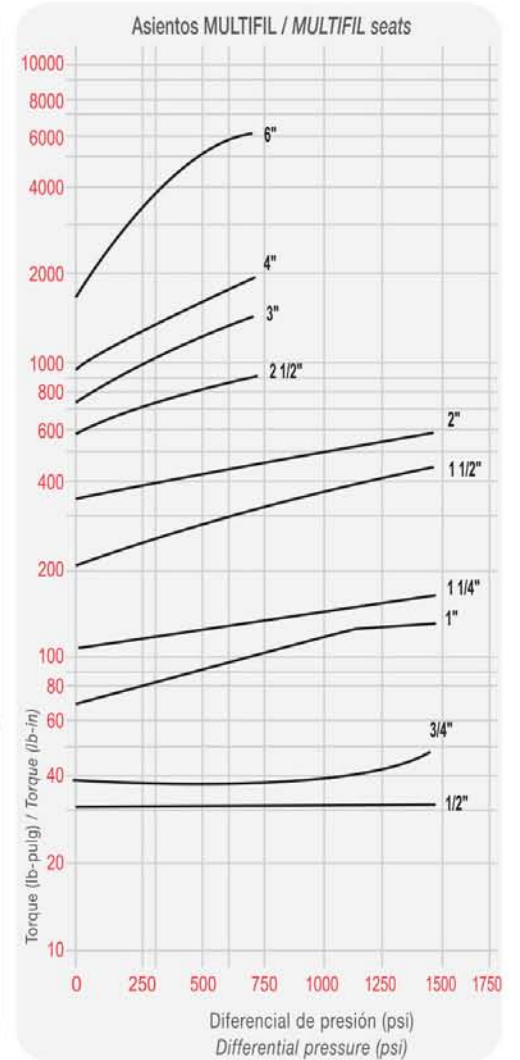
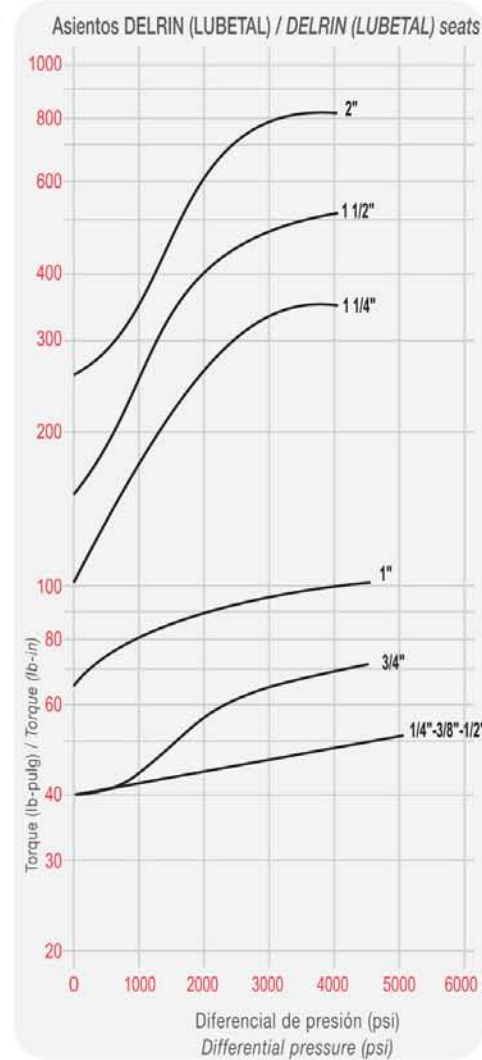
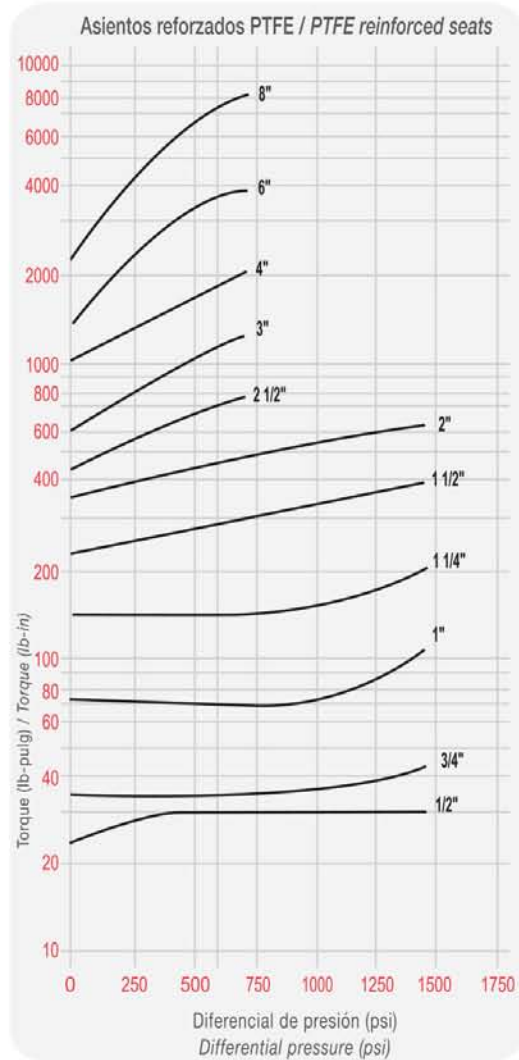
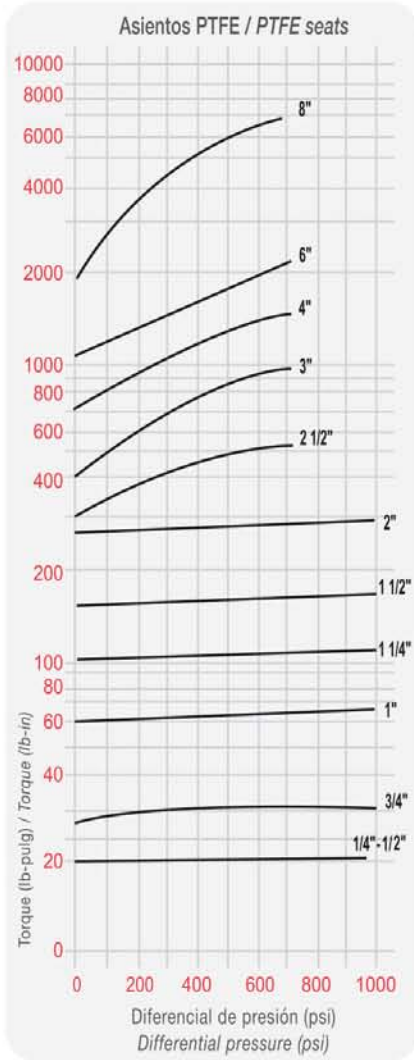

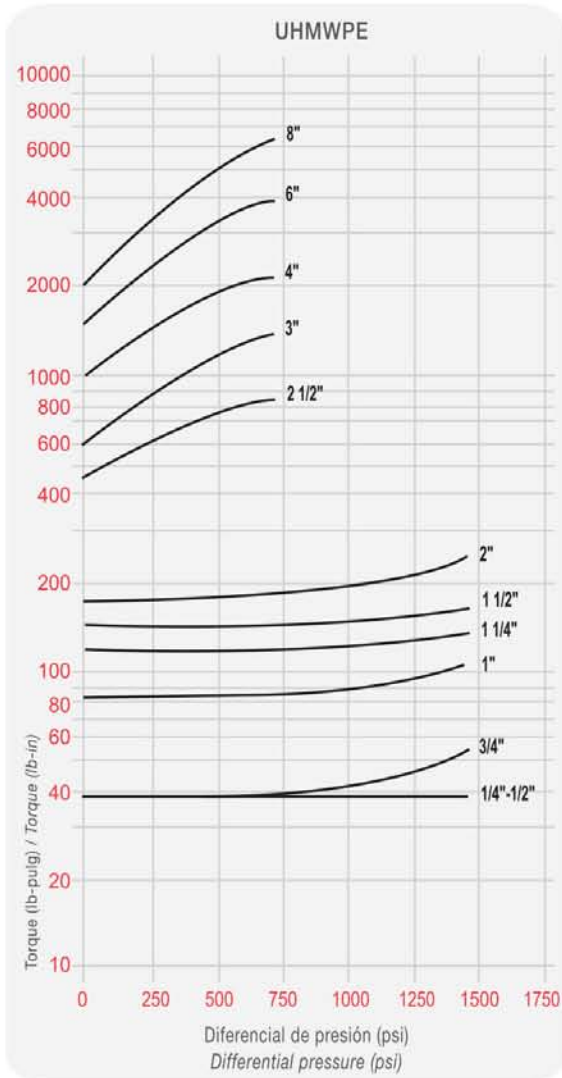

Nota: No está incluido el factor de seguridad

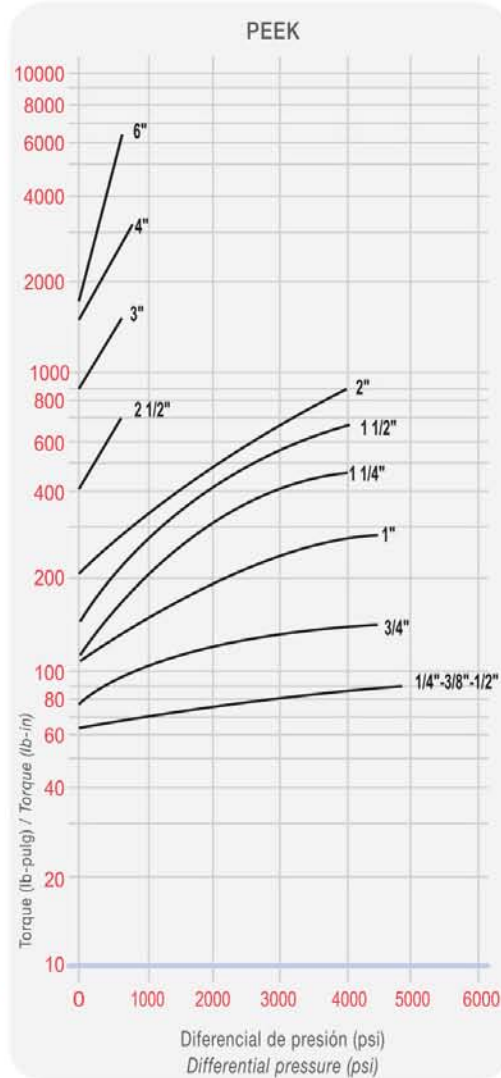

Note: The security factor is not included

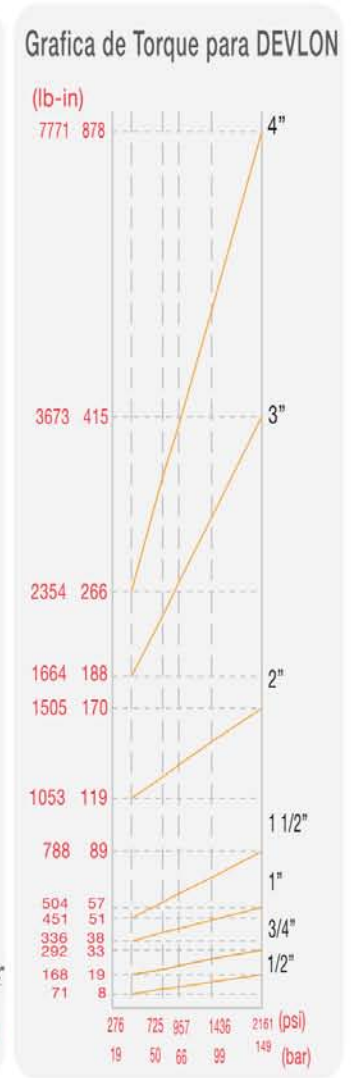
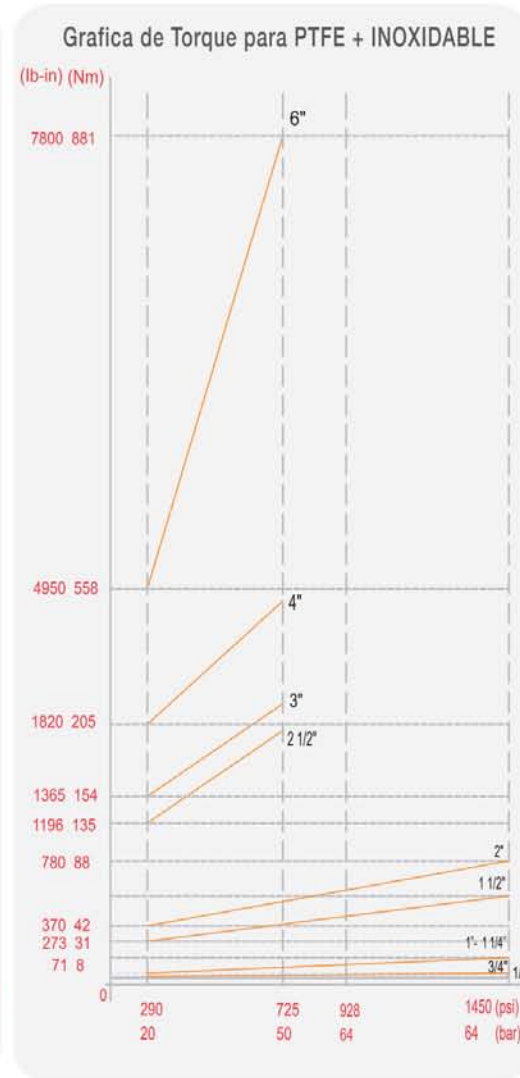

PEEK

PTFE

**TORQUE VÁLVULAS DE BOLA FLOTANTE
FLOATING BALL VALVE TORQUE**

*Tomar en cuenta Factor de Seguridad.
*Please consider Safety Factor.

CLASS	PSI	PN	Serie 400, Paso Reducido / Reduce Bore Series 400												Serie 400, Paso Completo / Full Bore Series 400											
			TAMAÑO / SIZE												TAMAÑO / SIZE											
			1/2"		3/4"		1"		1 1/4"		1 1/2"		2"		1/2"		3/4"		1"		1 1/4"		1 1/2"		2"	
Class	PSI	PN	lb-in	Nm	lb-in	Nm	lb-in	Nm	lb-in	Nm	lb-in	Nm	lb-in	Nm	lb-in	Nm	lb-in	Nm	lb-in	Nm	lb-in	Nm	lb-in	Nm		
400	990	64	156	17.6	330	37.3	468	52.9	530	59.9	564	63.7	1070	120.9	330	37.3	468	52.9	530	59.9	564	63.7	1070	120.9	2030	229.4
600	1440	100	159	18.0	332	37.5	472	53.3	532	60.1	572	64.6	1075	121.5	332	37.5	472	53.3	532	60.1	572	64.6	1075	121.5	2042	230.7
900	2220	150	164	18.5	335	37.9	476	53.8	535	60.5	576	65.1	1080	122.0	335	37.9	476	53.8	535	60.5	576	65.1	1080	122.0	2052	231.9

CLASS	WOG	BAR	Serie H600 Paso Reducido / Reduce Bore Series H600											
			TAMAÑO / SIZE											
			1/2"		3/4"		1"		1 1/2"		2"			
Class	WOG	BAR	lb-in	Nm	lb-in	Nm	lb-in	Nm	lb-in	Nm	lb-in	Nm		
NONE	3000	206	340	38.4	484	54.7	540	61.0	1090	123.2	1962	221.7		

**TORQUE VÁLVULAS DE BOLA FLOTANTE
FLOATING BALL VALVE TORQUE**

*Tomar en cuenta Factor de Seguridad.
*Please consider Safety Factor.

CLASS	PSI	PN	Serie 400 Paso Reducido / Reduce Bore Series 400												Serie 400 Paso Completo / Full Bore Series 400											
			TAMAÑO / SIZE												TAMAÑO / SIZE											
			1/2"		3/4"		1"		1 1/4"		1 1/2"		2"		1/2"		3/4"		1"		1 1/4"		1 1/2"		2"	
Class	PSI	PN	lb-in	Nm	lb-in	Nm	lb-in	Nm	lb-in	Nm	lb-in	Nm	lb-in	Nm	lb-in	Nm	lb-in	Nm	lb-in	Nm	lb-in	Nm	lb-in	Nm		
150	285	20	22	2.5	30	3.4	53	6.0	90	10.2	145	16.4	220	24.9	--	--	--	--	--	--	--	--	--	--	--	
300	740	50	23	2.6	32	3.6	63	7.1	100	11.3	155	17.5	245	27.7	--	--	--	--	--	--	--	--	--	--	--	
400	990	64	25	2.8	70	7.9	75	8.5	100	11.3	443	50	260	29.4	32	3.6	67	7.6	100	11.3	160	18.1	443	50	640	72.3

CLASS	PSI	PN	Serie 45, 150 y 300 Paso Reducido / Reduce Bore Series 45, 150 & 300													
			TAMAÑO / SIZE													
			2 1/2"		3"		4"		6"		8"		10"			
Class	PSI	PN	lb-in	Nm	lb-in	Nm	lb-in	Nm	lb-in	Nm	lb-in	Nm	lb-in	Nm	lb-in	Nm
150	285	20	295	33.3	680	76.8	1000	113.0	3363	380	4200	474.6	5250	593.2		
300	740	50	550	62.1	1000	113.0	1400	158.2	2200	248.6	7200	813.6				

CLASS	PSI	PN	Serie 152 y 302 Paso Completo / Full Bore Series 152 & 302																	
			TAMAÑO / SIZE																	
			1/2"		3/4"		1"		1 1/2"		2"		3"		4"		6"		8"	
Class	PSI	PN	lb-in	Nm	lb-in	Nm	lb-in	Nm	lb-in	Nm	lb-in	Nm	lb-in	Nm	lb-in	Nm	lb-in	Nm		
150	285	20	30	3.4	53	6.0	90	10.2	220	24.9	295	33.3	680	76.8	1000	113.0	1400	158.2	4425	500
300	740	50									550	62.1	1770	200	1400	158.2	2200	248.6		

CLASS	PSI	PN	Serie 15 Paso Reducido / Reduce Bore Series 15													
			TAMAÑO / SIZE													
			1"		1 1/2"		2"		2 1/2"		3"		4"		6"	
Class	PSI	PN	lb-in	Nm	lb-in	Nm	lb-in	Nm	lb-in	Nm	lb-in	Nm	lb-in	Nm	lb-in	Nm
150	285	20	53	6.0	145	16.4	220	24.9	295	33.3	680	76.8	1000	113.0	1400	158.2

**TORQUE VÁLVULAS DE BOLA FLOTANTE
FLOATING BALL VALVE TORQUE**

*Tomar en cuenta Factor de Seguridad.
*Please consider Safety Factor.

Class	PSI	PN	SERIE 400, PASO REDUCIDO / REDUCE BORE SERIES 400												SERIE 400, PASO COMPLETO / FULL BORE SERIES 400											
			TAMAÑO / SIZE																							
			1/2"		3/4"		1"		1 1/4"		1 1/2"		2"		1/2"		3/4"		1"		1 1/4"		1 1/2"		2"	
lb-in	Nm	lb-in	Nm	lb-in	Nm	lb-in	Nm	lb-in	Nm	lb-in	Nm	lb-in	Nm	lb-in	Nm	lb-in	Nm	lb-in	Nm	lb-in	Nm	lb-in	Nm			
150	285	20	38	4.3	51	5.7	71.5	8.1	97	11.0	273	30.8	377	42.6	50.7	5.7	71.5	8.1	126.1	14.2	273	30.8	377	42.6	962	108.7
300	740	50	42	4.7	52	5.9	104	11.8	130	14.7	390	44.1	494	55.8	52	5.9	104	11.8	169	19.1	390	44.1	494	55.8	1196	135.1
400	990	64	42	4.7	56	6.3	133	15.0	155	17.5	455	51.4	708	80	55.9	6.3	132.6	15.0	201.5	22.8	455	51.4	533	60.2	1508	170.4
600	1440	100	42	4.7	71.5	8.1	169	19.1	160	18.1	559	63.2	780	88.1	71.5	8.1	169	19.1	208	23.5	559	63.2	780	88.1	1885	213.0

CLASS	PSI	PN	SERIE 45, 150 y 300 PASO REDUCIDO / REDUCE BORE SERIES 45, 150 & 300											
			TAMAÑO / SIZE											
			2 1/2"		3"		4"		6"		8"		10"	
Class	PSI	PN	lb-in	Nm	lb-in	Nm	lb-in	Nm	lb-in	Nm	lb-in	Nm	lb-in	Nm
150	285	20	962	108.7	1365	154.2	1820	205.6	4940	558.2	10296	1163	12545	1418
300	740	50	1196	135.1	1950	220.3	2600	293.8	7800	881.4	17160	1939		

CLASS	PSI	PN	SERIE 152 y 302 PASO COMPLETO / FULL BORE SERIES 152 & 302																	
			TAMAÑO / SIZE																	
			1/2"		3/4"		1"		1 1/2"		2"		3"		4"		6"		8"	
Class	PSI	PN	lb-in	Nm	lb-in	Nm	lb-in	Nm	lb-in	Nm	lb-in	Nm	lb-in	Nm	lb-in	Nm	lb-in	Nm		
150	285	20	50.7	5.7	71.5	8.1	126.1	14.2	377	42.6	962	108.7	1365	154.2	1820	205.6	4940	558.2	10296	1163
300	740	50									1196	135.1	1950	220.3	2600	293.8	7800	881.4		

CLASS	PSI	PN	SERIE 15, PASO REDUCIDO / REDUCED BORE SERIES 15													
			TAMAÑO / SIZE													
			1"		1 1/2"		2"		2 1/2"		3"		4"		6"	
Class	PSI	PN	lb-in	Nm	lb-in	Nm	lb-in	Nm	lb-in	Nm	lb-in	Nm	lb-in	Nm	lb-in	Nm
150	285	20	71.5	8.1	273	30.8	377	42.6	962	108.7	1365	154.2	1820	205.6	4940	558.2

CLASS	PSI	PN	SERIE 400, PASO REDUCIDO CRIOGENICA / REDUCED BORE SERIES 400 CRYOGENIC												SERIE 400, PASO COMPLETO CRIOGENICA / FULL BORE SERIES 400 CRYOGENIC											
			TAMAÑO / SIZE																							
			1/2"		3/4"		1"		1 1/4"		1 1/2"		2"		1/2"		3/4"		1"		1 1/4"		1 1/2"		2"	
Class	PSI	PN	lb-in	Nm	lb-in	Nm	lb-in	Nm	lb-in	Nm	lb-in	Nm	lb-in	Nm	lb-in	Nm	lb-in	Nm	lb-in	Nm	lb-in	Nm	lb-in	Nm		
400	990	64	100	11.3	200	22.6	250	28.25	563	63.62	885	100	969	109.49	200	22.6	250	28.25	563	63.62	872	98.53	969	109.49	1470	166.1

PTFE+ INOXIDABLE SS/PTFE Filled

TORQUE VÁLVULAS DE BOLA FLOTANTE
FLOATING BALL VALVE TORQUE

*Tomar en cuenta Factor de Seguridad.
*Please consider Safety Factor.

CLASS	PSI	PN	SERIE 400, PASO REDUCIDO / REDUCE BORE SERIES 400														SERIE 400, PASO COMPLETO / FULL BORE SERIES 400									
			TAMAÑO / SIZE														TAMAÑO / SIZE									
			1/2"		3/4"		1"		1 1/4"		1 1/2"		2"		1/2"		3/4"		1"		1 1/4"		1 1/2"		2"	
Class	PSI	PN	lb-in	Nm	lb-in	Nm	lb-in	Nm	lb-in	Nm	lb-in	Nm	lb-in	Nm	lb-in	Nm	lb-in	Nm	lb-in	Nm	lb-in	Nm	lb-in	Nm	lb-in	Nm
150	285	20	29	3.3	39	4.4	55	6.2	97	11.0	210	23.7	290	32.8	39	4.4	55	6.2	97	11.0	210	23.7	290	32.8	740	83.6
300	740	50	32	3.6	40	4.5	80	9.0	130	14.7	300	33.9	380	42.9	40	4.5	80	9.0	130	14.7	300	33.9	380	42.9	920	104.0
400	990	64	32	3.6	50	5.6	102	11.5	155	17.5	620	70	410	46.3	43	4.9	102	11.5	155	17.5	350	39.5	410	46.3	1160	131.1
600	1440	100	32	3.6	55	6.2	130	14.7	160	18.1	430	48.6	600	67.8	55	6.2	130	14.7	160	18.1	430	48.6	600	67.8	1450	163.8

CLASS	PSI	PN	SERIE 45, 150 y 300 PASO REDUCIDO / REDUCE BORE SERIES 45, 150 & 300													
			TAMAÑO / SIZE													
			2 1/2"		3"		4"		6"		8"		10"			
Class	PSI	PN	lb-in	Nm	lb-in	Nm	lb-in	Nm	lb-in	Nm	lb-in	Nm	lb-in	Nm	lb-in	Nm
150	285	20	740	83.6	1050	118.6	1400	158.2	3800	429.4	7920	895	9650	1090		
300	740	50	920	104.0	1500	169.5	2000	226.0	6000	678.0	13200	1492				

CLASS	PSI	PN	SERIE 152 Y 302 PASO COMPLETO / FULL BORE SERIES 152 & 302																	
			TAMAÑO / SIZE																	
			1/2"		3/4"		1"		1 1/2"		2"		3"		4"		6"		8"	
Class	PSI	PN	lb-in	Nm	lb-in	Nm	lb-in	Nm	lb-in	Nm	lb-in	Nm	lb-in	Nm	lb-in	Nm	lb-in	Nm		
150	285	20	39	4.4	55	6.2	97	11.0	290	32.8	740	83.6	1050	118.6	1400	158.2	3800	429.4	7920	895
300	740	50									920	104.0	1500	169.5	2000	226.0	6000	678.0		

CLASS	PSI	PN	SERIE 15, PASO REDUCIDO / REDUCED BORE SERIES 15													
			TAMAÑO / SIZE													
			1"		1 1/2"		2"		2 1/2"		3"		4"		6"	
Class	PSI	PN	lb-in	Nm	lb-in	Nm	lb-in	Nm	lb-in	Nm	lb-in	Nm	lb-in	Nm	lb-in	Nm
150	285	20	55	6.2	210	23.7	290	32.8	740	83.6	1050	118.6	1400	158.2	3800	429.4

CLASS	PSI	PN	SERIE 400, PASEO REDUCIDO / REDUCE BORE SERIES 400												SERIE 400, PASEO COMPLETO / FULL BORE SERIES 400											
			TAMAÑO / SIZE												TAMAÑO / SIZE											
			1/2"		3/4"		1"		1 1/4"		1 1/2"		2"		1/2"		3/4"		1"		1 1/4"		1 1/2"		2"	
Class	PSI	PN	lb-in	Nm	lb-in	Nm	lb-in	Nm	lb-in	Nm	lb-in	Nm	lb-in	Nm	lb-in	Nm	lb-in	Nm	lb-in	Nm	lb-in	Nm	lb-in	Nm		
150	285	20	37	4.2	38	4.3	77	8.7	113	12.8	142	16.0	172	19.4	38	4.3	77	8.7	113	12.8	142	16.0	172	19.4	640	72.3
300	740	50	42	4.7	40	4.5	79	8.9	120	13.6	150	16.9	179	20.2	40	4.5	79	8.9	120	13.6	150	16.9	179	20.2	880	99.4
400	990	64	42	4.7	40	4.5	82	9.3	125	14.1	155	17.5	186	21.0	40	4.5	82	9.3	125	14.1	155	17.5	186	21.0	1100	124.3
600	1440	100	47	5.3	44	5.0	100	11.3	138	15.6	178	20.1	222	25.1	44	5.0	100	11.3	138	15.6	178	20.1	222	25.1		

TORQUE VÁLVULAS DE BOLA FLOTANTE
FLOATING BALL VALVE TORQUE

CLASS	PSI	PN	SERIE 45, 150 y 300 PASEO REDUCIDO / REDUCE BORE SERIES 45, 150 & 300											
			TAMAÑO / SIZE											
			2"		3"		4"		6"		8"			
Class	PSI	PN	lb-in	Nm	lb-in	Nm	lb-in	Nm	lb-in	Nm	lb-in	Nm	lb-in	Nm
150	285	20	640	72.3	940	106.2	1600	180.8	2600	293.8	3900	440.7		
300	740	50	880	99.4	1500	169.5	2100	237.3	4000	452.0	6500	734.5		

*Tomar en cuenta Factor de Seguridad.
*Please consider Safety Factor.

CLASS	PSI	PN	SERIE 152 y 302 PASEO COMPLETO / FULL BORE SERIES 152 & 302																	
			TAMAÑO / SIZE																	
			1/2"		3/4"		1"		1 1/2"		2"		3"		4"		6"		8"	
Class	PSI	PN	lb-in	Nm	lb-in	Nm	lb-in	Nm	lb-in	Nm	lb-in	Nm	lb-in	Nm	lb-in	Nm	lb-in	Nm		
150	285	20	38	4.3	77	8.7	113	12.8	172	19.4	640	72.3	940	106.2	1600	180.8	2600	293.8	3900	440.7
300	740	50									880	99.4	1500	169.5	2100	237.3	4000	452.0		

CLASS	PSI	PN	SERIE 15, PASEO REDUCIDO / REDUCED BORE SERIES 15													
			TAMAÑO / SIZE													
			1"		1 1/2"		2"		2 1/2"		3"		6"			
Class	PSI	PN	lb-in	Nm	lb-in	Nm	lb-in	Nm	lb-in	Nm	lb-in	Nm	lb-in	Nm		
150	285	20	77	8.7	142	16.0	172	19.4	640	72.3	940	106.2	1600	180.8	2600	293.8

CLASS	PSI	PN	SERIE 400, PASEO REDUCIDO / REDUCE BORE SERIES 400												SERIE 400, PASEO COMPLETO / FULL BORE SERIES 400											
			TAMAÑO / SIZE												TAMAÑO / SIZE											
			1/2"		3/4"		1"		1 1/4"		1 1/2"		2"		1/2"		3/4"		1"		1 1/4"		1 1/2"		2"	
Class	PSI	PN	lb-in	Nm	lb-in	Nm	lb-in	Nm	lb-in	Nm	lb-in	Nm	lb-in	Nm	lb-in	Nm	lb-in	Nm	lb-in	Nm	lb-in	Nm	lb-in	Nm		
150	285	20	27	3.1	35	4.0	50	5.6	130	14.7	230	26.0	410	46.3	35	4.0	50	5.6	130	14.7	230	26.0	410	46.3	590	66.7
300	740	50	29	3.3	35	4.0	58	6.6	135	15.3	302	34.1	520	58.8	35	4.0	58	6.6	135	15.3	302	34.1	520	58.8	740	83.6
400	990	64	29	3.3	37	4.2	69	7.8	150	16.9	350	39.5	580	65.5	37	4.2	69	7.8	150	16.9	350	39.5	580	65.5	900	101.7
600	1440	100	30	3.4	45	5.1	110	12.4	210	23.7	400	45.2	615	69.5	45	5.1	110	12.4	210	23.7	400	45.2	615	69.5		

TORQUE VÁLVULAS DE BOLA FLOTANTE
FLOATING BALL VALVE TORQUE

CLASS	PSI	PN	SERIE 45, 150 y 300 PASEO REDUCIDO / REDUCE BORE SERIES 45, 150 & 300											
			TAMAÑO / SIZE											
			2 1/2"		3"		4"		6"		8"		10"	
Class	PSI	PN	lb-in	Nm	lb-in	Nm	lb-in	Nm	lb-in	Nm	lb-in	Nm	lb-in	Nm
150	285	20	590	66.7	850	96.0	1350	152.5	2300	259.9	4800	542.4	6030	681.4
300	740	50	740	83.6	1400	158.2	2200	248.6	3900	440.7	8200	926.6		
400	990	64	900	101.7										

*Tomar en cuenta Factor de Seguridad.
*Please consider Safety Factor.

CLASS	PSI	PN	SERIE 152 y 302 PASEO COMPLETO / FULL BORE SERIES 152 & 302																	
			TAMAÑO / SIZE																	
			1/2"		3/4"		1"		1 1/2"		2"		3"		4"		6"		8"	
Class	PSI	PN	lb-in	Nm	lb-in	Nm	lb-in	Nm	lb-in	Nm	lb-in	Nm	lb-in	Nm	lb-in	Nm	lb-in	Nm		
150	285	20	35	4.0	50	5.6	130	14.7	410	46.3	590	66.7	850	96.0	1350	152.5	2300	259.9	4800	542.4
300	740	50									740	83.6	1400	158.2	2200	248.6	3900	440.7		

CLASS	PSI	PN	SERIE 15, PASEO REDUCIDO / REDUCED BORE SERIES 15													
			TAMAÑO / SIZE													
			1"		1 1/2"		2"		2 1/2"		3"		6"			
Class	PSI	PN	lb-in	Nm	lb-in	Nm	lb-in	Nm	lb-in	Nm	lb-in	Nm	lb-in	Nm		
150	285	20	50	5.6	230	26.0	410	46.3	590	66.7	850	96.0	1350	152.5	2300	259.9

DELTRIN

TORQUE VÁLVULAS DE BOLA FLOTANTE
FLOATING BALL VALVE TORQUE

*Tomar en cuenta Factor de Seguridad.
*Please consider Safety Factor.

CLASS	PSI	PN	SERIE 400, PASO REDUCIDO / REDUCE BORE SERIES 400										SERIE 400, PASO COMPLETO / FULL BORE SERIES 400													
			TAMAÑO / SIZE										TAMAÑO / SIZE													
			1/2"		3/4"		1"		1 1/4"		1 1/2"		2"		1/2"		3/4"		1"		1 1/4"		1 1/2"		2"	
Class	PSI	PN	lb-in	Nm	lb-in	Nm	lb-in	Nm	lb-in	Nm	lb-in	Nm	lb-in	Nm	lb-in	Nm	lb-in	Nm	lb-in	Nm	lb-in	Nm	lb-in	Nm		
150	285	20	38	4.3	56	6.3	68	7.7	105	11.9	160	18.1	240	27.1	56	6.3	68	7.7	105	11.9	160	18.1	240	27.1	320	36.2
300	740	50	40	4.5	60	6.8	73	8.2	145	16.4	202	22.8	298	33.7	60	6.8	73	8.2	145	16.4	202	22.8	298	33.7	418	47.2
400	990	64	42	4.7	63	7.1	79	8.9	160	18.1	230	26.0	315	35.6	63	7.1	79	8.9	160	18.1	230	26.0	315	35.6	450	50.8
600	1440	100	44	5.0	66	7.5	85	9.6	200	22.6	300	33.9	440	49.7	66	7.5	85	9.6	200	22.6	300	33.9	440	49.7	528	59.7
900	2220	150	46	5.2	69	7.8	105	11.9	254	28.7	381	43.1	552	62.4	69	7.8	105	11.9	254	28.7	381	43.1	552	62.4	770	87.0

CLASS	WOG	BAR	SERIE H600 PASO REDUCIDO / REDUCE BORE SERIES H600											
			TAMAÑO / SIZE											
			1/2"		3/4"		1"		1 1/4"		1 1/2"		2"	
Class	WOG	BAR	lb-in	Nm	lb-in	Nm	lb-in	Nm	lb-in	Nm	lb-in	Nm	lb-in	Nm
NONE	3000	206	56	6.3	68	7.7	105	11.9	160	18.1	240	27.1	320	36.2

CLASS	PSI	BAR	SERIE 6000 PASO COMPLETO / FULL BORE SERIES 600									
			TAMAÑO / SIZE									
			1/2"		3/4"		1"		1 1/2"		2"	
Class	PSI	BAR	lb-in	Nm	lb-in	Nm	lb-in	Nm	lb-in	Nm	lb-in	Nm
2500	6000	414	165	18.6	80	9	620	70	1062	120	810	91.5

CLASS	PSI	PN	PTFE					
			TAMAÑO / SIZE					
			2"		3"		4"	
Class	PSI	PN	lb-in	Nm	lb-in	Nm	lb-in	Nm
150	285	20	295	33.3	1000	113	1400	158.2
300	740	50	550	62.1	1400	158.2	2200	248.6

CLASS	PSI	PN	R-PTFE					
			TAMAÑO / SIZE					
			2"		3"		4"	
Class	PSI	PN	lb-in	Nm	lb-in	Nm	lb-in	Nm
150	285	20	590	66.7	1350	152.5	2300	259.9
300	740	50	740	83.6	2200	248.6	3900	440.7

CLASS	PSI	PN	MULTIFIL					
			TAMAÑO / SIZE					
			2"		3"		4"	
Class	PSI	PN	lb-in	Nm	lb-in	Nm	lb-in	Nm
150	285	20	740	83.6	1400	158.2	3800	429.4
300	740	50	920	104	2300	259.9	6000	678

CLASS	PSI	PN	SSI/PTFE					
			TAMAÑO / SIZE					
			2"		3"		4"	
Class	PSI	PN	lb-in	Nm	lb-in	Nm	lb-in	Nm
150	285	20	962	108.7	1820	205.6	4940	558.2
300	740	50	1196	135.1	2600	293.8	7800	881.4

VALVULA TRUNNION MULTIPUERTOS DE 6" SERIE 18 CLASE 150
6" MULTIPORT TRUNNION VALVE CLASS 150 SERIES 18

R-PTFE				
Class	PSI	PN	lb-in	NM
150	285	20	8097	915

MULTIFIL				
Class	PSI	PN	lb-in	NM
150	285	20	8097	915

PTFE+INOXIDABLE				
Class	PSI	PN	lb-in	NM
150	285	20	8097	915

SERIE 18 PASO COMPLETO (150# y 300#)
SERIES 18 FULL BORE (150# & 300#)

Normas internacionales aplicables

Estándar	Descripción	Aplicable a	Tamaños	Comentarios
NACE MR-0175	Requerimientos de materiales. Resistencia de materiales para ambientes amargos en campos de extracción sometidos a esfuerzos por corrosión y esfuerzos por agrietamiento debido a la presencia de sulfuros.	Todas las series excepto válvulas fabricadas en latón A solicitud del Cliente	Todos	Requerimientos de los materiales para válvulas a ser utilizadas en campos de extracción de petróleo, campos de perforación y equipos en líneas de flujo.
ANSI FCI-70-2	Fugas por asientos en válvulas de control	Válvulas con asientos metálicos	N/A	Clases de fugas en válvulas de control
MSS SP-25	Estándar para el sistema de marcaje en válvulas accesorios, bridas y uniones	Todas las series excepto serie 1000	Todos	Marcaje usado para identificar la información general de válvulas, accesorios, bridas y uniones.
MSS SP-55	Estándar de calidad para válvulas, bridas, accesorios y otros componentes fabricados de acero fundido. Método visual para evaluación de irregularidades superficiales.	Todas las series excepto válvulas fabricadas en latón	Todos	Información adicional para la inspección visual de la calidad de válvulas fundidas.
API-6D	Válvulas en líneas de conducción PT, bridada y BW.	Serie 152/302 y Trunnion	2" y mayores 1/2" a 8"	Recomendaciones para la fabricación de válvulas para la industria del petróleo y gas natural.
API-607	Pruebas de fuego para válvulas de 1/4 de vuelta con asiento suave.	Todas las series excepto serie H600, 150/300 y válvulas de latón	1/2" a 8"	Requerimientos para probar válvulas que están expuestas a eventos de fuego.
API-6FA	Pruebas de fuego para válvulas	Válvulas Trunnion	2" a 48"	Requerimientos para probar válvulas que están expuestas a eventos de fuego.
API-598	Inspección y prueba de válvulas.	Todas las series	Todos	Requerimientos de inspección y pruebas para válvulas.
ASME B16.5	Bridas para tubería y accesorios bridados.	Todas las series Bridadas	1/2" a 24"	Rangos de presión-temperatura, materiales, dimensiones, tolerancias, pruebas, marcado y diseño de bridas.
ASME B16.10	Dimensiones cara-cara y extremo-extremo de válvulas.	Todas las series bridadas y soldadas a tope	1/4" a 36"	Dimensiones cara-cara y extremo-extremo de válvulas.
ASME B16.11	Accesorios forjados, caja soldable y roscados.	Todas las series excepto bridadas y soldadas a tope	1/4" a 4"	Rangos, materiales, dimensiones, tolerancias, pruebas y marcaje para extremos roscados y caja soldable.
ASME B16.25	Extremos soldables a tope.	Todas las series soldables a tope	2 1/2" a 48"	Preparación de extremos soldables a tope.
ASME B16.34	Válvulas bridadas, roscadas y con extremos soldables.	Todas las series	1/2" a 36"	Rangos de presión-temperatura, materiales, dimensiones, tolerancias, pruebas, marcado y diseño de válvulas.
NACE MR-0103	Requerimientos de materiales. Resistencia de materiales sometidos a esfuerzos por corrosión debido a la presencia de sulfuro para ambientes amargos en refinarias de petróleo.	Todas las series excepto válvulas fabricadas en latón A solicitud del Cliente	Todos	Requerimientos para materiales de válvulas a ser usadas en ambientes corrosivos en refinarias.

Applicable international standard

Standard	Description	Applicable to	Sizes	Comments
NACE MR-0175	Standard material requirements. Material resistance for sulfide stress cracking and stress corrosion cracking in sour oilfield environments	All series except for valves made of Brass On Customer request	All sizes	Material requirements for valves working at petroleum production fields, drilling fields, gathering and flow line equipment
ANSI FCI-70-2	Control valve seat leakage	Metal seat Valves	N/A	Classes of leakage for control valves
MSS SP-25	Marking system's standard for valves, fitting, flanges and unions	all series except for series 1000	All sizes	Marking used to identify general information for valves, fittings, flanges and unions used in piping connections
MSS SP-55	Quality standard for steel castings for valves, flanges, fittings and other piping components. visual method for evaluation of surface irregularities.	All series except for valves made of Brass	All sizes	additional information for visual examination of valve's quality made of castings
API-6D	Pipeline valves, flanged and BW	All series except for valves made of Brass	2" and over 1/2" a 8"	Recommendations for valve's manufacture for petroleum and natural gas industries
API-607	Fire Test for soft-seated quarter-turn valves.	All series except series H600, 150, 300 & valves made of Brass	1/2" to 8"	Requirements for testing valves exposed to fire events
API-6FA	Fire Test for Valves	Trunnion Valves	2" to 48"	Requirements for testing valves exposed to fire events
API-598	Valve's inspection and testing	All series	All sizes	Inspection and test requirements for valves
ASME B16.5	Pipe flanges and flanged fittings	All flanged Series	1/2" to 24"	Pressure-temperature ratings, materials, dimensions, tolerances, testings, marking and design for flanges
ASME B16.10	Face-to-face and end-to-end dimensions	All flanged and buttwelding series	1/4" to 36"	Face-to-face and end-to-end dimensions of straightway valves
ASME B16.11	Forged fittings, socket-welding and threaded	All series except flanged and buttwelding series	1/4" to 4"	Rating, materials, dimensions, tolerances, testing and marking for socket-welding and threaded ends
ASME B16.25	Buttwelding ends	All buttwelding series all series	2 1/2" to 48"	Preparation of buttwelding ends of piping components
ASME B16.34	Valves-flanged, threaded and welding end	All series	1/2" to 36"	Pressure-temperature ratings, materials, dimensions, tolerances, testings, marking and design for valves
NACE MR-0103	Material resistant to sulfide stress cracking in corrosive petroleum refining environments	All series except for valves made of Brass On Customer request	All sizes	Material requirements for valves working in corrosive petroleum refining environments

**SERIES 82, 83, 84, 85 & 86 TWO and THREE PIECES TRUNNION BALL VALVE TORQUE, RPTFE SEATS
for 150# to 600# & NYLON SEATS for 900# to 1500#**

SIZE	CLASS	PSI	DN	PN	bar	Nm	lb-ft	SIZE	CLASS	PSI	DN	PN	bar	Nm	lb-ft	SIZE	CLASS	PSI	DN	PN	bar	Nm	lb-ft
2"	150	285	50	20	19.65	49	36	3"	150	285	80	20	19.65	60	44	4"	150	285	100	20	19.65	151	111
2"	300	740	50	50	51.02	86	63	3"	300	740	80	50	51.02	109	80	4"	300	740	100	50	51.02	268	198
2"	600	1480	50	100	102.04	146	108	3"	600	1480	80	100	102.04	190	140	4"	600	1480	100	100	102.04	459	339
2"	900	2220	50	150	153.06	207	153	3"	900	2220	80	150	153.06	270	199	4"	900	2220	100	150	153.06	649	479
2"	1500	3705	50	250	255.45	327	241	3"	1500	3705	80	250	255.45	431	318	4"	1500	3705	100	250	255.45	1032	761
6"	150	285	150	20	19.65	314	232	8"	150	285	200	20	19.65	1018	751	10"	150	285	250	20	19.65	1083	799
6"	300	740	150	50	51.02	541	399	8"	300	740	200	50	51.02	1604	1183	10"	300	740	250	50	51.02	1829	1349
6"	600	1480	150	100	102.04	908	670	8"	600	1480	200	100	102.04	2557	1886	10"	600	1480	250	100	102.04	3044	2245
6"	900	2220	150	150	153.06	1276	941	8"	900	2220	200	150	153.06	3510	2589	10"	900	2220	250	150	153.06	4257	3140
6"	1500	3705	150	250	255.45	2012	1484	8"	1500	3705	200	250	255.45	5423	4000	10"	1500	3705	250	250	255.45	6694	4937
12"	150	285	300	20	19.65	1559	1150	14"	150	285	350	20	19.65	2423	1787	16"	150	285	400	20	19.65	3015	2224
12"	300	740	300	50	51.02	2601	1918	14"	300	740	350	50	51.02	4243	3130	16"	300	740	400	50	51.02	5349	3945
12"	600	1480	300	100	102.04	4297	3169	14"	600	1480	350	100	102.04	7203	5313	16"	600	1480	400	100	102.04	9141	6742
12"	900	2220	300	150	153.06	5993	4420	14"	900	2220	350	150	153.06	10162	7495	16"	900	2220	400	150	153.06	12936	9541
12"	1500	3705	300	250	255.45	9394	6929	14"	1500	3705	350	250	255.45	16102	11876	16"	1500	3705	400	250	255.45	20547	15155
18"	150	285	450	20	19.65	4571	3371	20"	150	285	500	20	19.65	6010	4433	22"	150	285	550	20	19.65	6932	5113
18"	300	740	450	50	51.02	7970	5878	20"	300	740	500	50	51.02	10569	7795	22"	300	740	550	50	51.02	12139	8953
18"	600	1480	450	100	102.04	13497	9955	20"	600	1480	500	100	102.04	17984	13264	22"	600	1480	550	100	102.04	20607	15199
18"	900	2220	450	150	153.06	19026	14033	20"	900	2220	500	150	153.06	25397	18732	22"	900	2220	550	150	153.06	29076	21445
18"	1500	3705	450	250	255.45	30120	22215	20"	1500	3705	500	250	255.45	40276	29706	22"	1500	3705	550	250	255.45	46068	33978
24"	150	285	600	20	19.65	9710	7162	26"	150	285	650	20	19.65	11947	8812	28"	150	285	700	20	19.65	14510	10702
24"	300	740	600	50	51.02	17237	12713	26"	300	740	650	50	51.02	20337	15000	28"	300	740	700	50	51.02	25066	18488
24"	600	1480	600	100	102.04	29477	21741	26"	600	1480	650	100	102.04	33982	25064	28"	600	1480	700	100	102.04	42232	31149
24"	900	2220	600	150	153.06	41717	30769	26"	900	2220	650	150	153.06	47627	35128	28"	900	2220	700	150	153.06	59399	43810
24"	1500	3705	600	250	255.45	66280	48886																
30"	150	285	750	20	19.65	17984	13264	32"	150	285	800	20	19.65	21343	15742	34"	150	285	850	20	19.65	25357	18702
30"	300	740	750	50	51.02	31623	23324	32"	300	740	800	50	51.02	37530	27681	34"	300	740	850	50	51.02	43006	31720
30"	600	1480	750	100	102.04	53807	39686	32"	600	1480	800	100	102.04	63858	47099	34"	600	1480	850	100	102.04	71711	52891
30"	900	2220	750	150	153.06	75990	56047	32"	900	2220	800	150	153.06	90185	66517	34"	900	2220	850	150	153.06	100416	74063
36"	150	285	900	20	19.65	33170	24465	40"	150	285	1000	20	19.65	42906	31646	42"	150	285	1050	20	19.65	50751	37432
36"	300	740	900	50	51.02	56329	41546	40"	300	740	1000	50	51.02	72936	53795	42"	300	740	1050	50	51.02	86408	63731
36"	600	1480	900	100	102.04	93992	69325	40"	600	1480	1000	100	102.04	121778	89819	42"	600	1480	1050	100	102.04	144399	106503
36"	900	2220	900	150	153.06	131657	97105																
48"	150	285	1150	20	19.65	66926	49362																
48"	300	740	1150	50	51.02	113927	84028																
48"	600	1480	1150	100	102.04	190369	140409																

Tabla de torques para válvulas de bola Guiada • Trunnion torque table
Torque dado en esta tabla está dado en (N·M) lb-ft • Torque in this table is in (N·M) Lb-ft

Ejemplo:

2"	52	4	6	6	R	F	G	RF	L
1	2	3	4	5	6	7	8	9	10

Example

Código Code	Descripción • Description
1	Medida Size
2	Serie Series
3	Material del Cuerpo Body Material
4	Material de la Bola Ball Material
5	Material del Vástago Stem Material
6	Material del Asiento Seat Material
7	Aplicación especial Special Application
8	Material del Sello Seal Material
9	Tipo de Conexión Type of Connection
10	Operador Operator

1	Medida • Size
1/4"	DN8
3/8"	DN10
1/2"	DN15
3/4"	DN20
1"	DN25
1-1/4"	DN32
1-1/2"	DN40
2"	DN50
2-1/2"	DN65
3"	DN80
4"	DN100
6"	DN150
8"	DN200
10"	DN250

3	Material del Cuerpo (1 Dígito) Body material (1 Digit)
1	Latón Brass
4	Acero al Carbón Carbon Steel
6	Acero Inoxidable Stainless Steel
9	Especial Special

5	Material del Vástago (1 Dígito) Stem material (1 Digit)
4	Acero al Carbón Carbon Steel
6	Acero Inoxidable Stainless Steel
9	Especial Special

4	Material de la Bola (1 Dígito) Ball material (1 Digit)
1	Latón Brass
4	Acero al Carbón Carbon Steel
6	Acero Inoxidable Stainless Steel
9	Especial Special

6	Material del Asiento (1 Dígito) Seat material (1 Digit)
B	Buna-N Buna-NBR
D	Devlon Devlon
I	Teflon® + A/I Teflon® + Stainless Steel
M	Multifil Multifil
P	Peek Peek
R	Teflon® Reforzado (R-PTFE) Reinforced Teflon® (R-PTFE)
T	Teflon® Virgen (PTFE) Virgin Teflon® (PTFE)
Y	Delrhin-Lubetal Delrhin-Lubetal
9	Especial Special

2	Serie	Serie (2 dígitos) • Series (2 digits)
42	42	Modelo económico de 2 piezas (1/2" a 2") Economic model, 2 pieces (1/2" to 2")
10	1000	Cuerpo de 3 piezas (1/2" a 2"), paso completo 3-piece body (1/2" to 2"), full bore
44	400	Clase 400, de 3 piezas (1/4" a 2") paso reducido y completo Class 400, 3 pieces (1/4" to 2") full and reduce bore
66	600	Clase 600, de 3 piezas (1/4" a 2") paso reducido y paso completo Class 600, 3 pieces (1/4" to 2") full and reduce bore
45	45	Clase 300, de 3 piezas paso reducido y completo (2" 1/2 a 6") class 300, 3 pieces (2" 1/2 to 6") reduced and full bore
15	15	Clase 150, Bridada de 1 pieza (1" a 6"), paso reducido Flanged Class 150, 1 piece (1" to 6"), reduced bore
50	150	Clase 150, bridada, (1/2" a 10") paso reducido Class 150, flanged (1/2" to 10") reduced bore
30	300	Clase 300, bridada, (1/2" a 8") paso reducido Class 300, flanged (1/2" to 8") reduced bore
52	152	Clase 150, bridada, (1/2" a 8") paso completo Class 150, flanged (1/2" to 8") full bore
32	302	Clase 300, bridada, (2" a 6") paso completo Class 300, flanged (2" to 6") full bore
B6	600	Clase 600, de 3 piezas 2" Bridada paso completo Class 600, 3 piece flanged (2" to 6") full bore
51	151	Modelo corto para colocar entre bridas clase 150 de 1 pieza (3" a 6") Paso reducido Short-pattern model to be installed between flanges, class 150, 1 piece (3" to 6") reduced bore
H6	H600	Cuerpo de 3 piezas Alta presión (1/2" a 2") High Pressure, 3-piece body (1/2" to 2")
60	6000	Alta presión clase 2500, de 2 piezas paso completo (1/4" a 2") High Pressure class 2500, 2 pieces (1/4" to 2")
18	1815	Clase 150, multipuertos (2" a 6") Class 150, multiport (2" to 6")
19	1830	Clase 300, multipuertos (2" a 6") Class 300, multiport (2" to 6")

Servicio General General Service
 Uso Industrial Industrial Use
 Bridas Uso Industrial Flanged Industrial Use
 Válvulas Especiales Special Valves

8	Material del Sello (1 Dígito) Seal material (1 Digit)
T	Teflon® (PTFE) Teflon® (PTFE)
B	Buna-N Buna-NBR
G	Grafoil Graphite
V	Vitón Viton
U	UHMWPE UHMWPE
I	PTFE + SS (INOX) PTFE + SS (INOX)
M	Multifil Multifil
Y	Delrhin Delrhin

7	Aplicación Especial (1 Dígito) Special Application (1 Digit)
0	Estándar Standard
1	3 Vías Porting 1 3 Ways Porting 1
2	3 Vías Porting 2 3 Ways Porting 2
3	3 Vías Porting 3 3 Ways Porting 3
B	Vástago Antiestático Antistatic Device
C	Criogénica Cryogenic
D	Tuercas y Tornillos de Inox. Stainless Bolts and Nuts
F	A Prueba de Fuego Fire Safe
G	Plato ISO 5211 ISO 5211 Plate
I	Cuerpo ISO Body ISO
J	Enchquetada Jacketed
K	Bola con Barreno de Alivio Ball with relief hole
O	Servicio de Oxígeno Oxygen Service
P	Paso Completo Full Bore
Q	Servicio de Vacío Vacuum Service
X	Cavity Fill Cavity Fill
Z	Asientos Integrales Integral Seats

9	Tipo de Conexión (2 Dígito) Type of Connection (2 Digit)
BS	Rosca BSPT Threaded BSPT
BP	Rosca BSPP Threaded BSPP
CC	Conexión Clamp Connection Clamp
RF	Bridada Cara realzada (RF) Flanged Raised Face (RF)
NP	Rosca NPT Threaded NPT
SW	Soldable a Caja (SW) (SW) Socket Weld
B1	Buttweld (BW) P/ Ced. 10 Buttweld (BW) for Ced. 10
B4	Buttweld (BW) P/ Ced. 40 Buttweld (BW) for Ced. 40
B8	Buttweld (BW) P/ Ced. 80 Buttweld (BW) for Ced. 80
EX	Extensión de Tubo Pipe extension

10	Operador (1 Dígito) • Operator (1 Digit)
M	Maneral Handle
L	Vástago Desnudo Bare shaft
O	Maneral Oval Oval Handle
I	Maneral C/Dispositivo P/Candado Handle with Locking Device

Ejemplo:

14"	94	4	4E	2	4E	N	RF	G
1	2	3	4+R	5+R	6+R	7	8	9

Example

Código Code	Descripción • Description
1	Medida <i>Size</i>
2	Serie <i>Series</i>
3	Material del Cuerpo <i>Body Material</i>
4	Material de la Bola <i>Ball Material</i>
5	Material del Vástago <i>Stem Material</i>
6	Material del Anillo <i>Seat Ring Material</i>
R	Recubrimiento <i>Covering</i>
7	Inserto del Asiento <i>Seat Insert</i>
8	Tipo de Conexión <i>Type of Connection</i>
9	Operador <i>Operator</i>

5	Material del Vástago (1 Dígito) Stem material (1 Digit)
2	AISI 4140 <i>AISI 4140</i>
4	Acero al Carbón <i>Carbon Steel</i>
5	Acero Inoxidable 17-4PH <i>Stainless Steel 17-4PH</i>
6	Acero Inoxidable <i>Stainless Steel</i>
9	Especial <i>Special</i>

6	Material del Anillo del asiento (1 Dígito) Seat Ring Material (1 Digit)
4	Acero al Carbón <i>Carbon Steel</i>
6	Acero Inoxidable <i>Stainless Steel</i>
9	Especial <i>Special</i>

7	Inserto del Asiento (1 Dígito) Seat Insert (1 Digit)
T	Teflon® Virgen (PTFE) <i>Virgin Teflon® (PTFE)</i>
R	Teflon® Reforzado (R-PTFE) <i>Reinforced Teflon® (R-PTFE)</i>
P	Peek <i>Peek</i>
V	Vitón <i>Viton</i>
N	Nylon <i>Nylon</i>
M	Metal-Metal <i>Metal to Metal</i>

1	Medida • Size			
2"	DN50	18"	DN450	
3"	DN80	20"	DN500	
4"	DN100	22"	DN550	
6"	DN150	24"	DN600	
8"	DN200	30"	DN750	
10"	DN250	36"	DN900	
12"	DN300	40"	DN1000	
14"	DN350	42"	DN1050	
16"	DN400	48"	DN1200	

3	Material del Cuerpo (1 Dígito) Body Material (1 Digit)
4	Acero al Carbón <i>Carbon Steel</i>
6	Acero Inoxidable <i>Stainless Steel</i>
9	Especial <i>Special</i>

4	Material de la Bola (1 Dígito) Ball Material (1 Digit)
4	Acero al Carbón <i>Carbon Steel</i>
6	Acero Inoxidable <i>Stainless Steel</i>
9	Especial <i>Special</i>

8	Tipo de Conexión (2 Dígitos) Type of Connection (2 Digits)
RF	Bridada Cara realzada (RF) <i>Flanged Raised Face (RF)</i>
B1	Buttweld (BW) P/ Ced. 10 <i>Buttweld (BW) for Ced. 10</i>
B4	Buttweld (BW) P/ Ced. 40 <i>Buttweld (BW) for Ced. 40</i>
B8	Buttweld (BW) P/ Ced. 80 <i>Buttweld (BW) for Ced. 80</i>
TJ	Bridada RTJ <i>Flanged RTJ</i>

9	Operador (1 Dígito) • Operator (1 Digit)
M	Maneral <i>Handle</i>
L	Vástago Desnudo <i>Bare shaft</i>
G	Caja de Engranés <i>Gear Box</i>

2	Serie (2 dígitos) • Series (2 digits)
72	Clase 150 bridada, paso completo, cuerpo atornillado <i>Class 150, flanged, full bore, bolted body</i>
73	Clase 300 bridada, paso completo, cuerpo atornillado <i>Class 300, flanged, full bore, bolted body</i>
82	Clase 150 bridada, paso completo, cuerpo atornillado <i>Class 150, flanged, full bore, bolted body</i>
83	Clase 300 bridada, paso completo, cuerpo atornillado <i>Class 300, flanged, full bore, bolted body</i>
84	Clase 600 bridada, paso completo, cuerpo atornillado <i>Class 600, flanged, full bore, bolted body</i>
85	Clase 900 bridada, paso completo, cuerpo atornillado <i>Class 900, flanged, full bore, bolted body</i>
86	Clase 1500 bridada, paso completo, cuerpo atornillado <i>Class 1500, flanged, full bore, bolted body</i>
87	Clase 2500 bridada, paso completo, cuerpo atornillado <i>Class 2500, flanged, full bore, bolted body</i>
92	Clase 150 bridada, paso completo, cuerpo soldado <i>Class 150, flanged, full bore, fully welded body</i>
93	Clase 300 bridada, paso completo, cuerpo soldado <i>Class 300, flanged, full bore, fully welded body</i>
94	Clase 600 bridada, paso completo, cuerpo soldado <i>Class 600, flanged, full bore, fully welded body</i>
95	Clase 900 bridada, paso completo, cuerpo soldado <i>Class 900, flanged, full bore, fully welded body</i>
96	Clase 1500 bridada, paso completo, cuerpo soldado <i>Class 1500, flanged, full bore, fully welded body</i>
97	Clase 2500 bridada, paso completo, cuerpo soldado <i>Class 2500, flanged, full bore, fully welded body</i>

R	Recubrimiento (1 Dígito) Covering (1 Digit)
E	ENP <i>ENP</i>
W	Carburo de Tungsteno <i>Tungsten carbide</i>
S	Estellite <i>Stellite</i>
H	Cromo duro <i>Hard chrome</i>

FUNDIDO
CASTED

FORJADO
FORGED

Debido al continuo desarrollo de nuestra línea de productos.

Válvulas Worcester de México® / Rhino Valves Worldwide®
Se reserva el derecho de hacer cambios en diseño, materiales,
especificaciones o información contenida en este catálogo sin
previo aviso y esta libre de obligación de hacer cambios en
productos previamente ordenados o vendidos.

*Due to the continuous development of our product range,
Válvulas Worcester de México® / Rhino Valves Worldwide®
Reserves the right to make changes in design, material,
specifications, or information contained in this catalog
without notice, and is free of obligation to change
products previously ordered or sold.*

...More than **50** years
of engineering experience
INSIDE OUR VALVES...

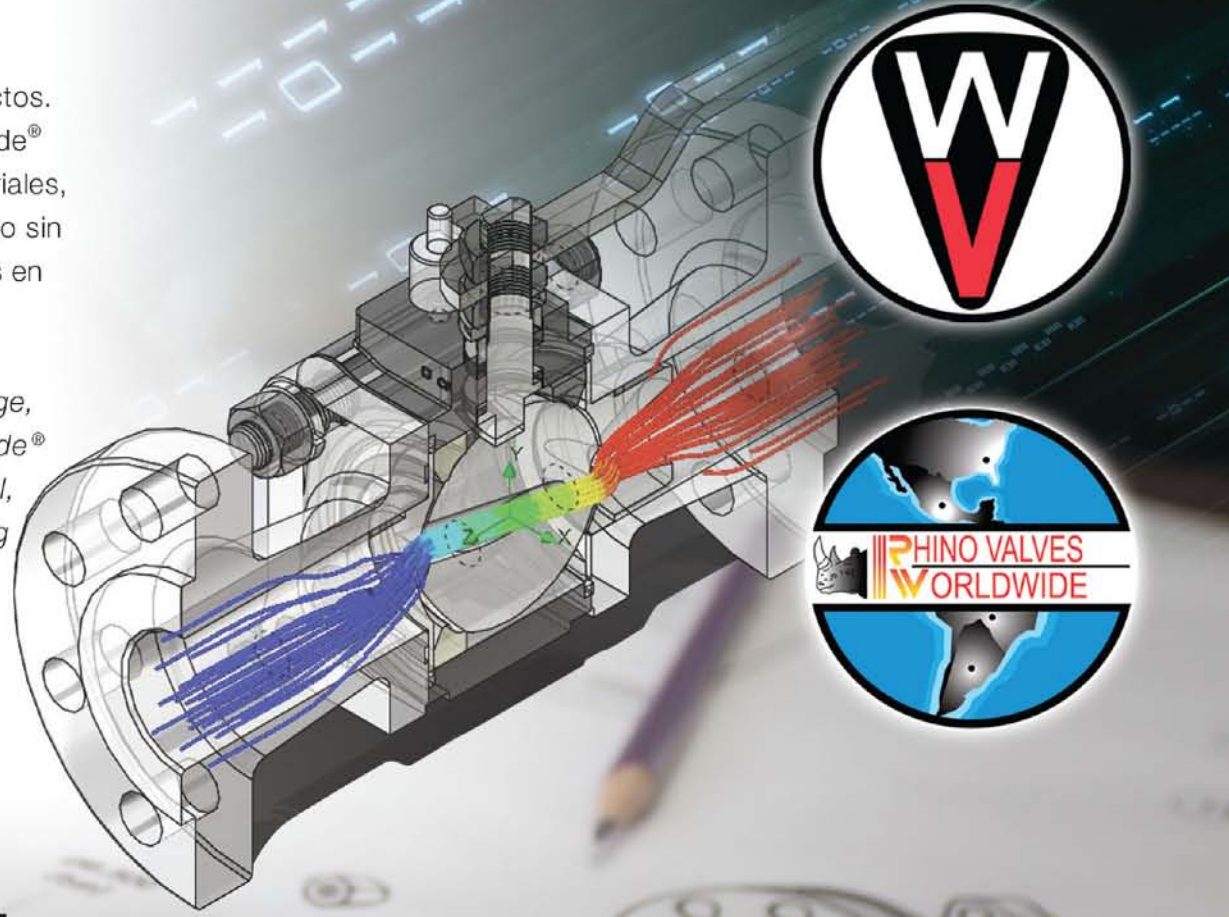

Válvulas Worcester de México® | Rhino Valves Worldwide®

www.worcester.com.mx



Válvulas Worcester de México,® S.A. de C.V. Rhino Valves Worldwide®

Distribuido por • Distributed by:

RHINO VALVES WORLDWIDE is a trademark of VÁLVULAS WORCESTER DE MÉXICO, S.A. DE C.V.

Maiz # 263 Col. Valle del Sur México D.F. C.P. 09819

Ventas Nacionales

Directo: (55) 5582•0030 Conm: (55) 5670•5155 115 Fax.
e-mail: a-clientes@worcester.com.mx

International Sales

Conm: (5255) 5670•5155 Ext. 150
e-mail: export-rhino@worcester.com.mx